

GROSSBEKOHLUNGSANLAGE



COALING STATION

GRAND CHARGEUR DE CHARBON

GROTE BEKOLINGSINSTALLATIE

Art. Nr. 120148

D

Machen Sie sich bitte vor Beginn des Bastelns mit dem Bausatzinhalt und der Anleitung vertraut und prüfen Sie die Vollständigkeit. Im Reklamationsfall gilt die gesetzliche Gewährleistungspflicht. Sollte ein Teil fehlen, übersenden Sie bitte den Teilwunsch und den Kaufbeleg an: Gebr. FALLER GmbH, Kundendienst, Kreuzstraße 9, D-78148 Gütenbach, kundendienst@faller.de. Sollten Sie einmal weitere Ersatzteile benötigen, senden wir Ihnen den benötigten Spritzling, bei Verfügbarkeit, gerne kostenpflichtig zu. Bitte beachten Sie, dass produktionsbedingt Einzelteile übrig bleiben können.

GB

Before building your model, please familiarize yourself with the contents of the kit and the instructions for use, also checking whether the set of parts is complete. In case of any complaint, the legal guarantee obligation shall apply. Should a part be missing, please send the designation of the part required and the receipt documenting your purchase to: Gebr. FALLER GmbH, Kundendienst, Kreuzstraße 9, D-78148 Gütenbach, kundendienst@faller.de. Should you require further spare parts one day, we shall be pleased to send you, with costs, the required sprue, if it is available. Please note that, on grounds of the production process, some single injection molded parts may be superfluous.

F

Avant de commencer votre modèle, veuillez vous familiariser avec le contenu du kit et la notice d'emploi, et contrôlez que le lot de pièces est complet. En cas de réclamation, il s'appliquera l'obligation de garantie légale. Au cas où une pièce manquerait, veuillez envoyer la désignation de la pièce souhaitée et le bon d'achat à: Gebr. FALLER GmbH, Kundendienst, Kreuzstraße 9, D-78148 Gütenbach, kundendienst@faller.de. Au cas où vous auriez besoin un jour d'autres pièces détachées, nous vous enverrons volontiers la grappe requise, si elle est disponible, contre paiement. Veuillez noter que, pour des raisons de production, il se peut que des pièces détachées soient superflues.

NL

Maak uzelf vóór het bouwen vertrouwd met de inhoud van het bouwpakket en met de handleiding en controleer de volledigheid. In geval van reclamatie geldt de wettelijke garantieverplichting. Mocht er een onderdeel ontbreken, stuur het verzoek om het gewenste onderdeel en het aankoopbewijs dan naar: Gebr. FALLER GmbH, klantenservice, Kreuzstraße 9, D-78148 Gütenbach, kundendienst@faller.de. Als u ooit meer reserveonderdelen nodig hebt, sturen wij het benodigde gietstuk, indien beschikbaar, graag tegen betaling naar u op. Let op: om productieredenen kunnen losse onderdelen overblijven.

Für den Zusammenbau des Modells empfehlen wir folgende FALLER-Artikel (sind nicht im Bausatz enthalten):

For the assembly of the kit we recommend following FALLER products (not included in the kit):

Pour l'assemblage du modèle, nous vous recommandons les articles FALLER suivants (non inclus dans le kit):

Om dit model te bouwen adviseren wij de volgende FALLER producten (maken geen deel uit van deze bouwset):

Art. Nr. 170490 | 170492 | 170494
FALLER SUPER-EXPERT | EXPERT | LASERCUT



Art. Nr. 170688
SPEZIAL-SEITENSCHNEIDER



Art. Nr. 170687
FALLER-BASTELMESSER

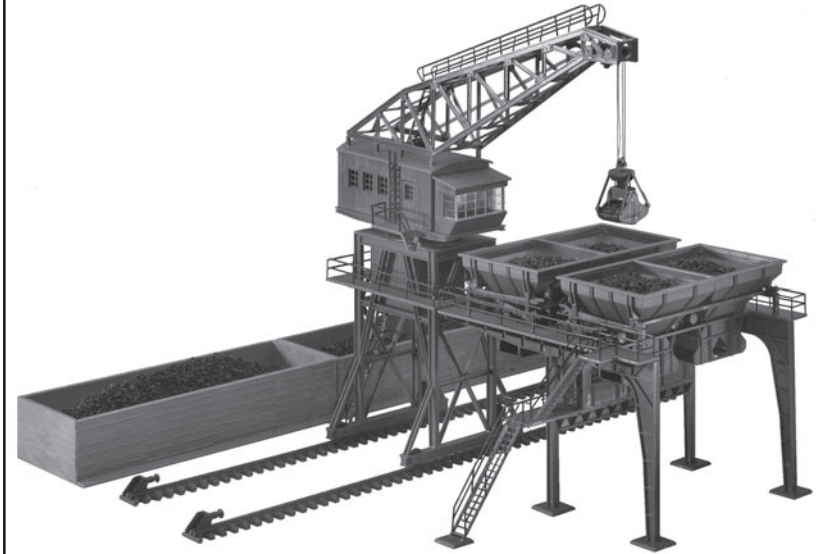

Inhalt	Spritzlinge	1	1 x	4	1 x	7	2 x	10	2 x
Contents	Sprues	2	1 x	5	1 x	8	1 x	11	1 x
Contenu	Moulages	3	1 x	6	1 x	9	1 x		
Inhoud	Gietstukken								

Sa. Nr. 144 720 0

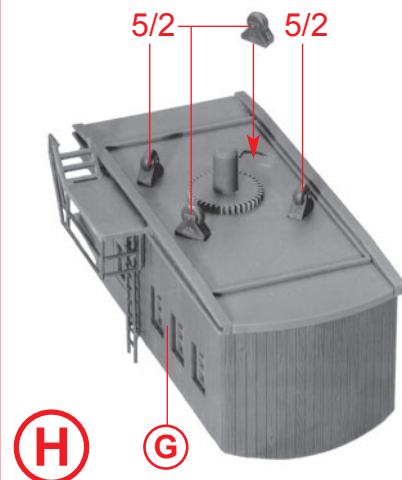
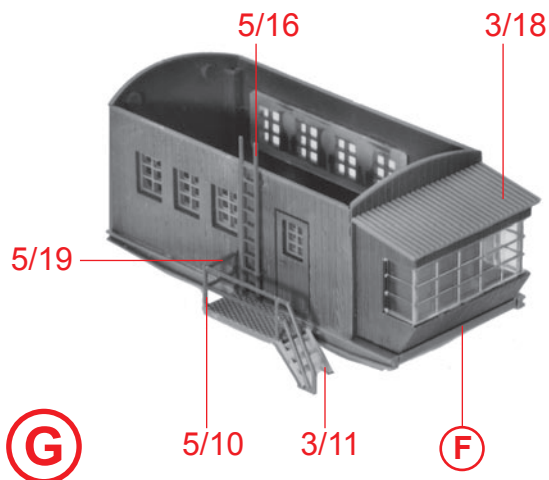
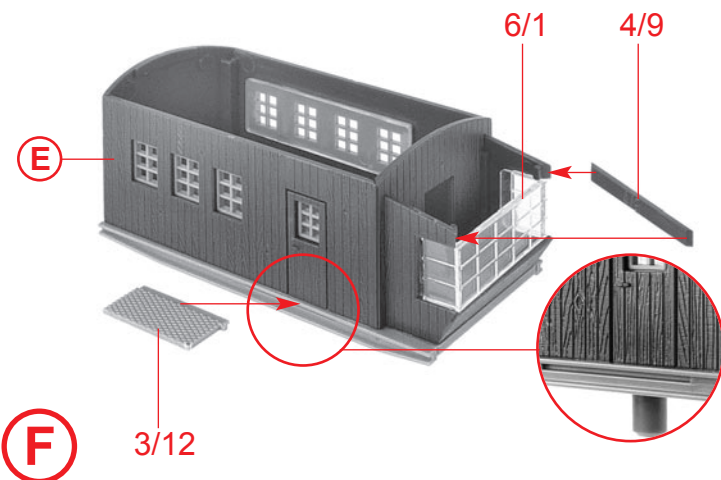
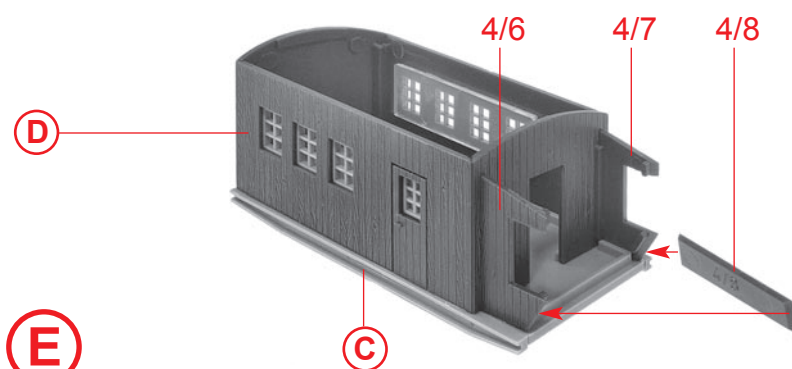
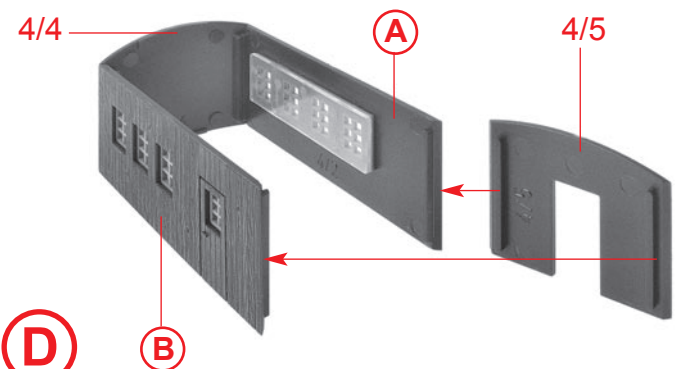
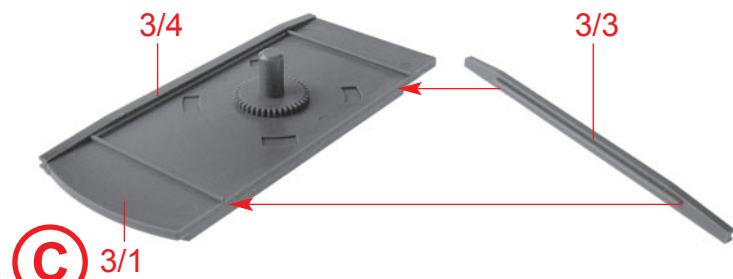
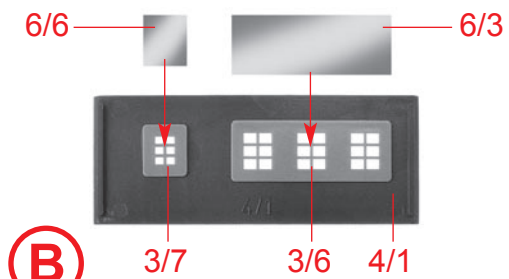
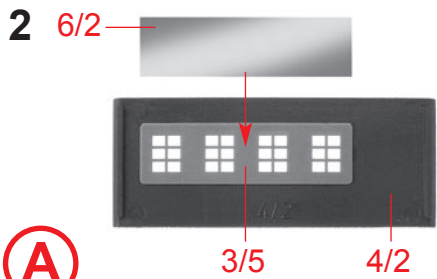

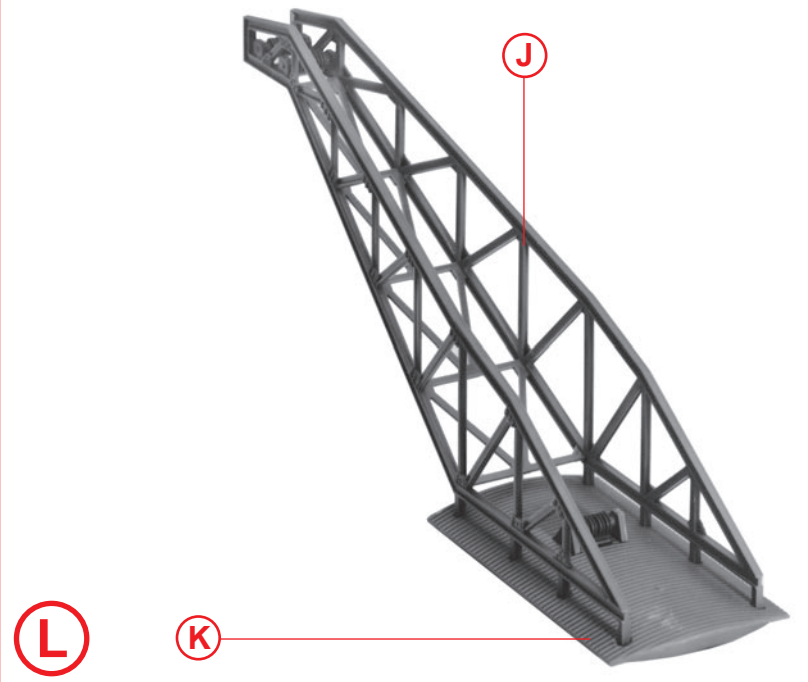
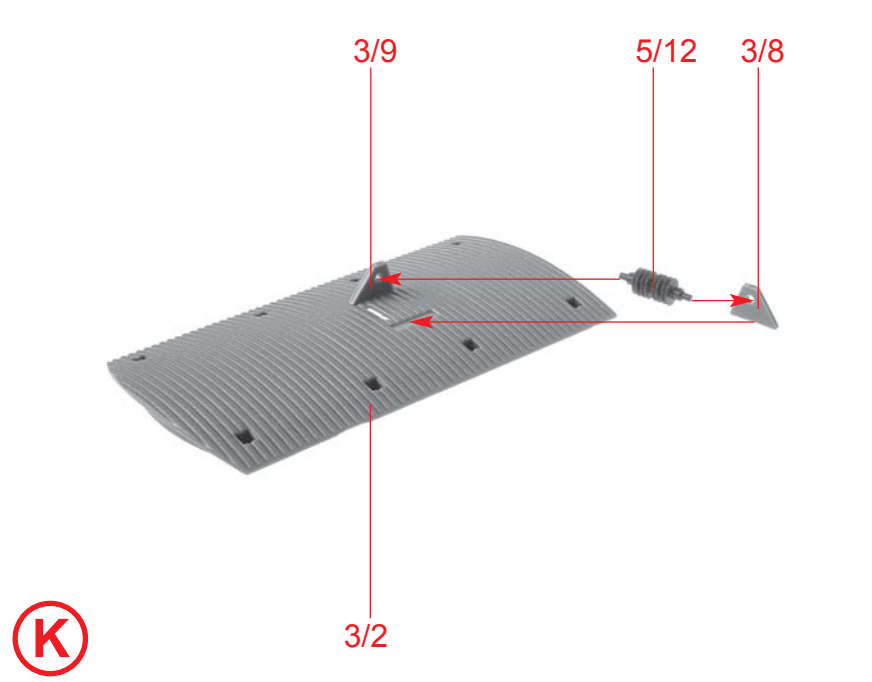
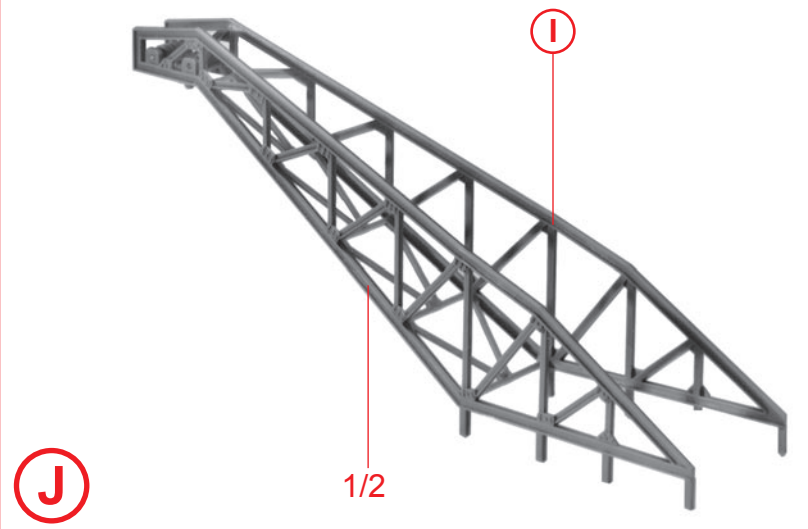
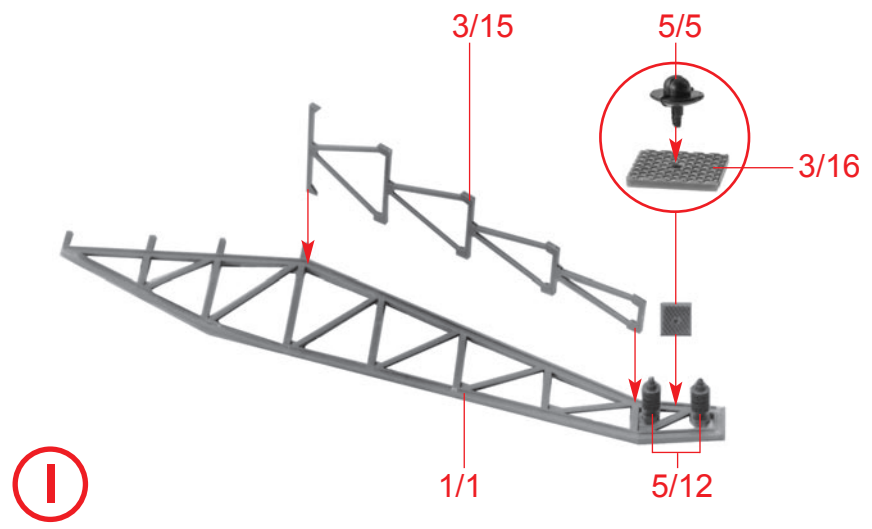

4

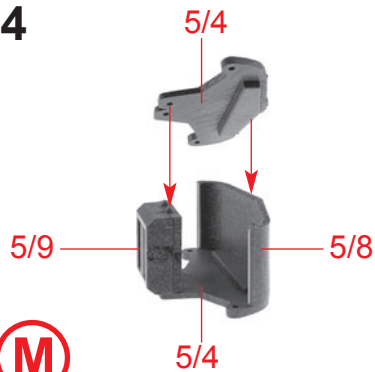

(M)

(N)

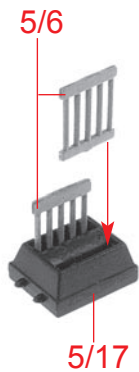

Faden liegt nicht bei
4 x 350 mm.
Cord not included.
Aiguillée non jointe.
Garen niet bijgevoegd.

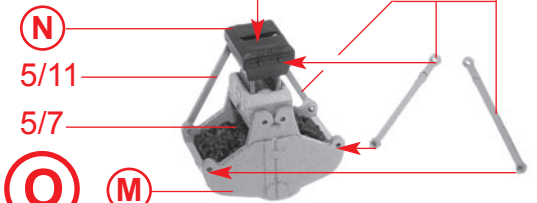

(O)

(P)

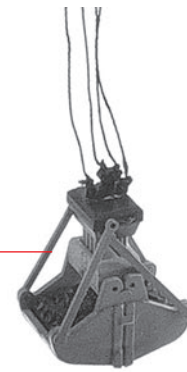

(P)

Sekundenkleber verwenden.
Use instant modelling cement.
Utilisez la colle rapide.
Gebruik secondenlijm.

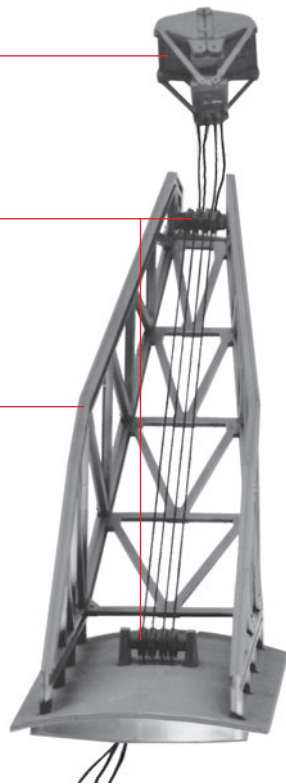

(L)

(Q)

Sekundenkleber verwenden.
Use instant modelling cement.
Utilisez la colle rapide.
Gebruik secondenlijm.

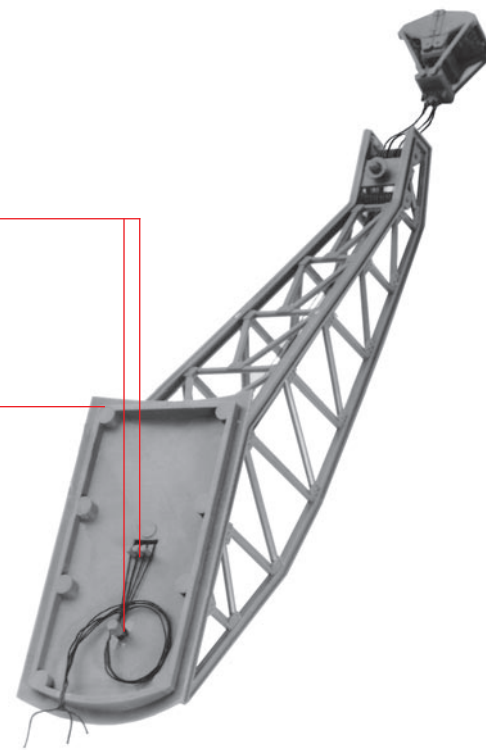

(Q)

(R)

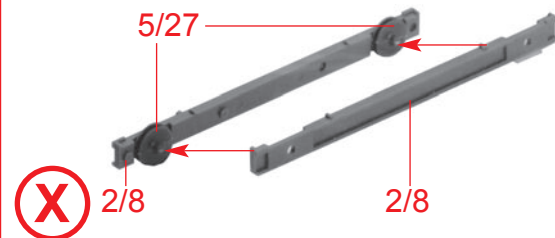
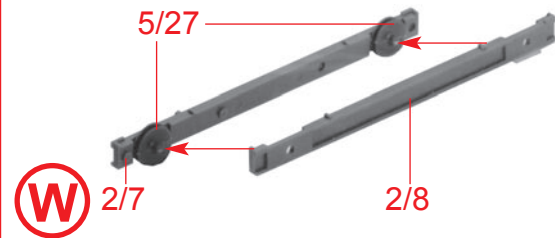
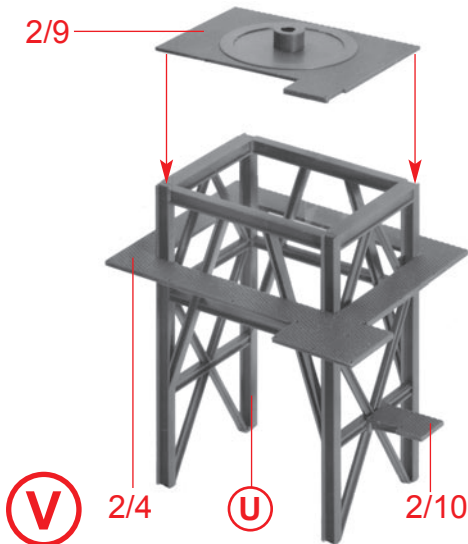
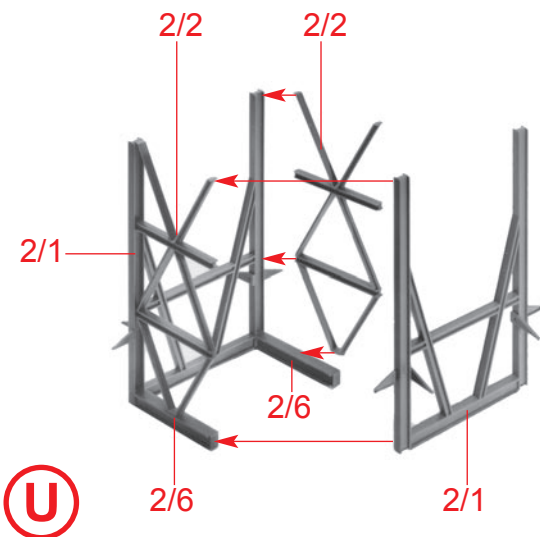
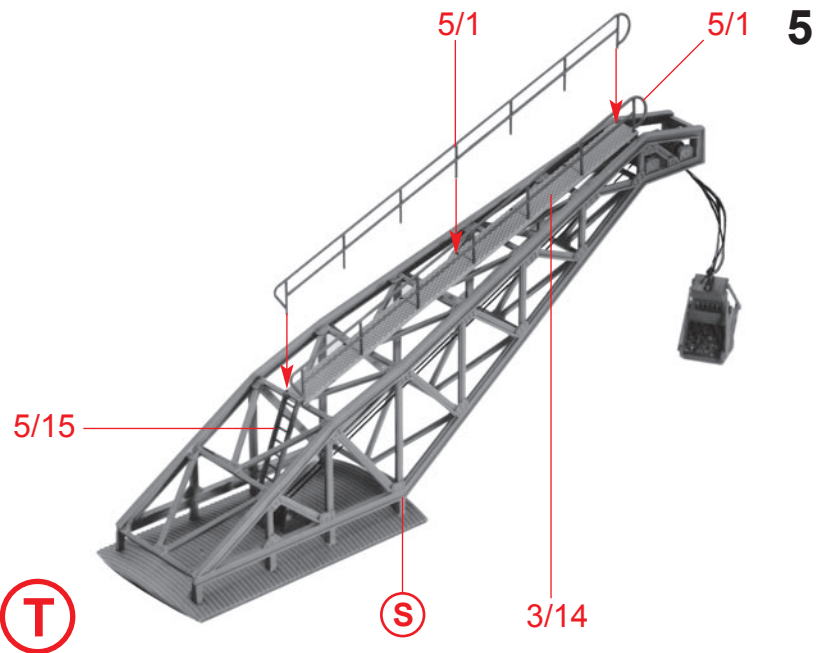
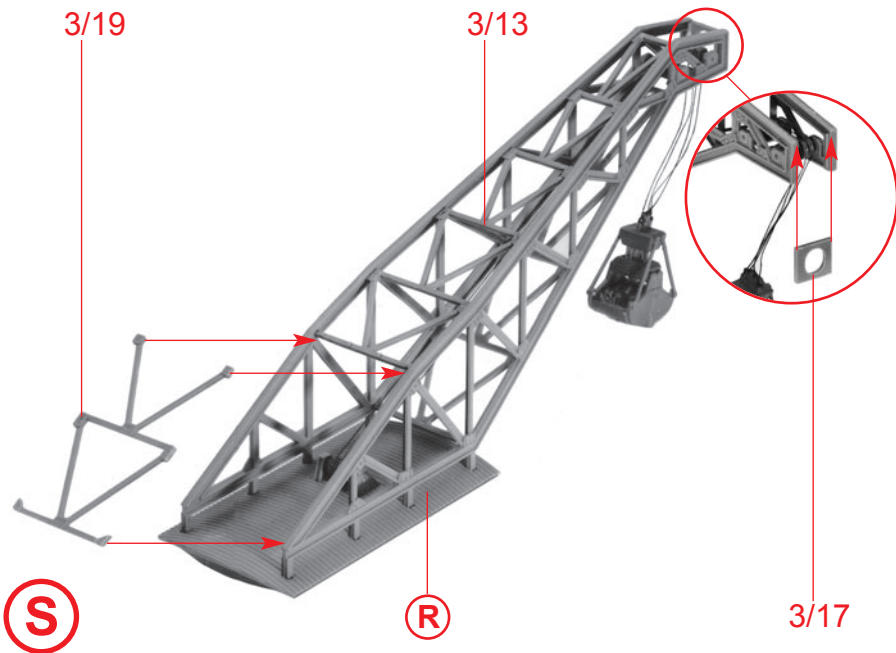

6

1/7

1/6

1/5

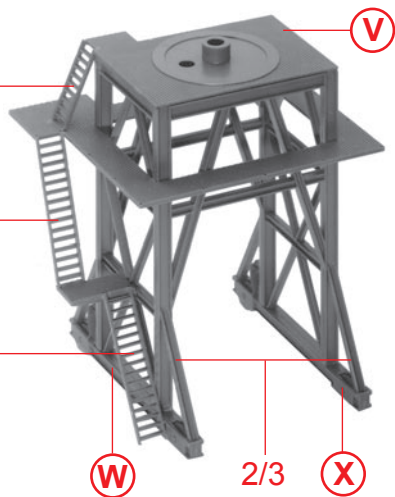

W

2/3

X

Einbaumöglichkeit für
Motor 180629 siehe Seite 7.

Possibilities to install
motor 180629 see page 7.

Possibilités de montage pour
le moteur 180629, voir page 7.

Inbouwmogelijkheid voor
motor 180629, zie blz. 7.

5/28

5/32

5/23

5/30

5/31

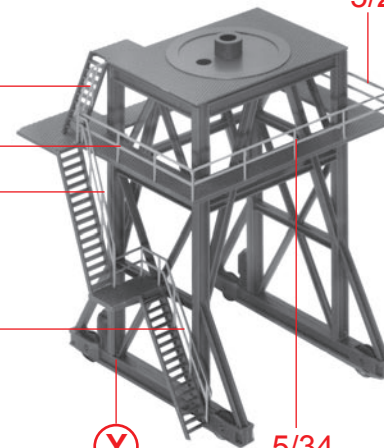

Y

5/34

Y

Z

5/25

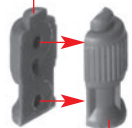

5/20

5/24

5/33

2/5

2/3

a

2/3

5/35

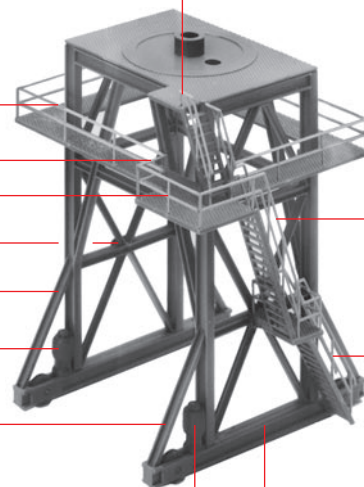

5/21

5/29

a

Z

T

H

b

Montagehilfe,
Mounting aid,
Aide de montage, ne pas coller
Montagehulp,
niet lijmen

c

6/5

4/3

5/22

5/22

4/3

5/22

5/22

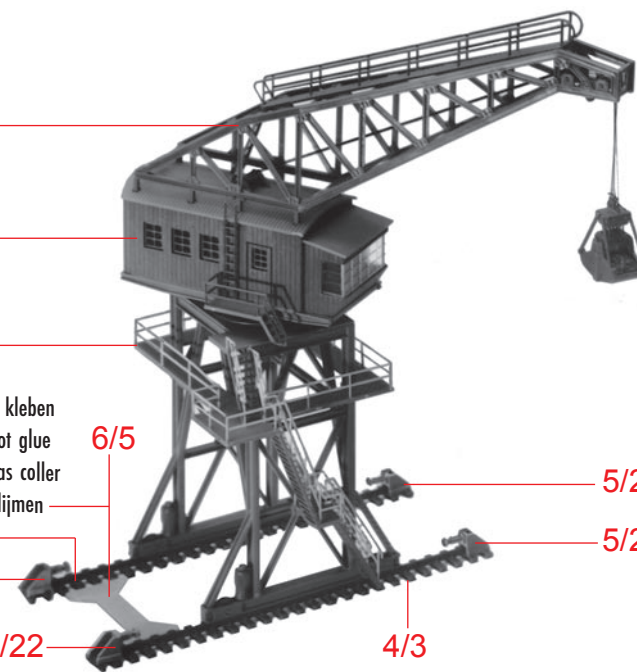

a 2 x 5/26

b

c

Motordrehrichtung

1. Der Motor kann durch den Schalter (Teil 1) auf Links- oder Rechtslauf geschaltet werden.
2. Durch entfernen der Teile 1 und 2 läuft der Motor unkontrolliert links oder rechts herum an.
In beiden Fällen kann der Motor durch Drucktaster oder Fernschalter betätigt werden.

Direction of rotation of motor

1. By means of part 1 (switch) the direction of rotation can be fixed.
 2. By removing parts 1 and 2 the motor will rotate uncontrolled.
- In both instances, the motor can be operated by means of a push-button panel or by remote-control.

Sens de rotation du moteur

1. Le moteur peut tourner vers la droite ou vers la gauche à l'aide du contact, pièce 1.
 2. En écartant les pièces 1 et 2 le moteur tourne indifféremment à droite ou à gauche sans contrôle.
- Dans les deux cas le moteur peut être commandé par un interrupteur ou par une commande à distance.

Draairichtung van de motor

1. De motor kan met de schakelaar (deel 1) op links of rechts draaiend worden ingesteld.
 2. Door verwijdering van de delen 1 en 2 draait de motor as ongecontroleerd naar links of rechts.
- In beide gevallen kan de motor met een drukknop-schakelaar of relais worden ingeschakeld.

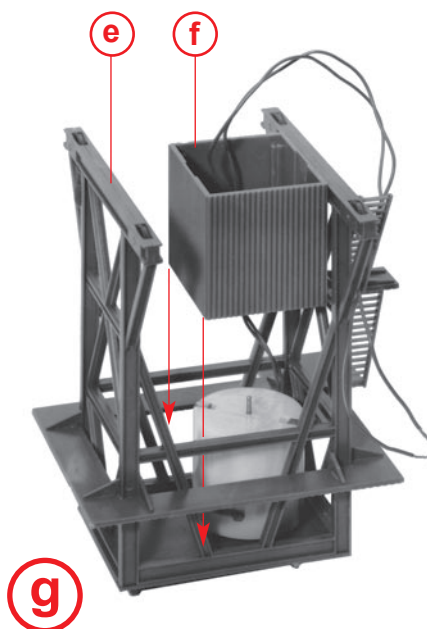
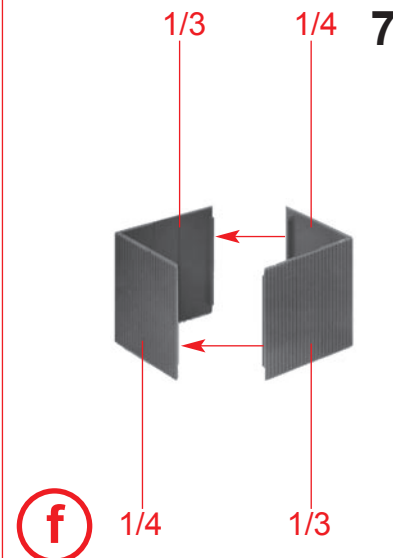
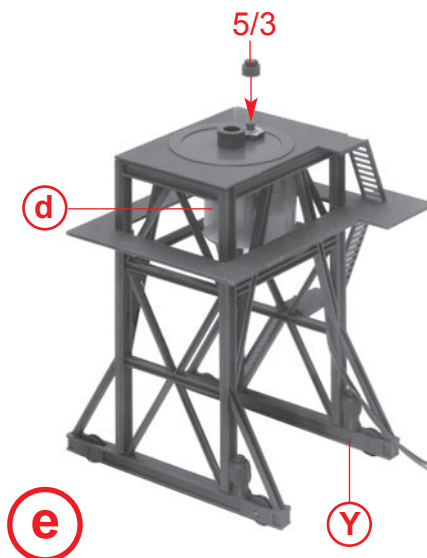
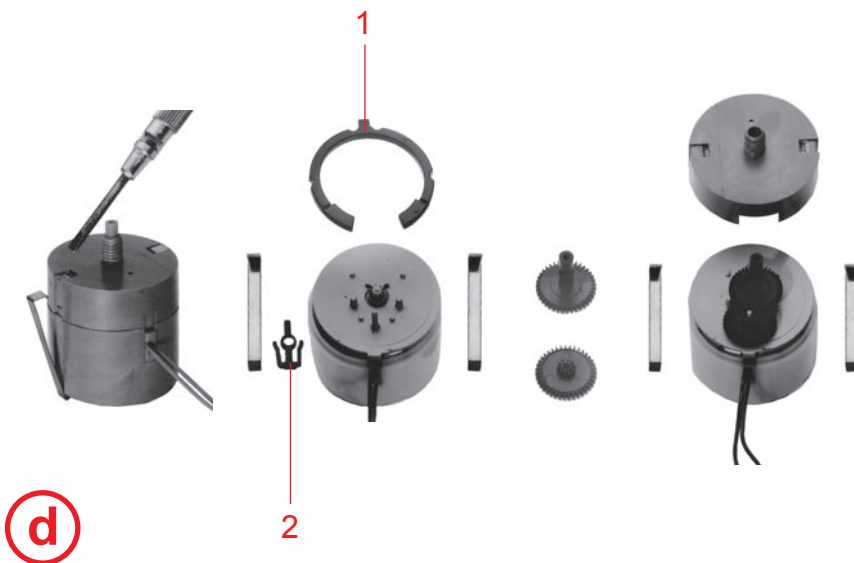

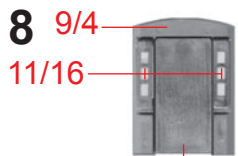

i

11/12

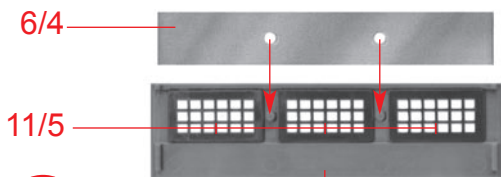

j 2 x

9/3

k

noch nicht kleben
do not glue yet
ne colle pas encore
nog niet lijmen



8/2

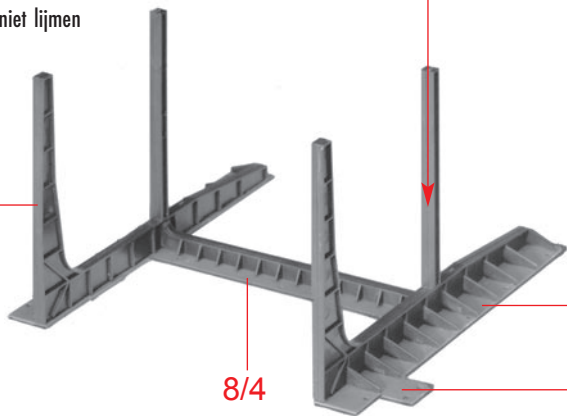

l

8/4

8/1

9/1

8/3

l

m

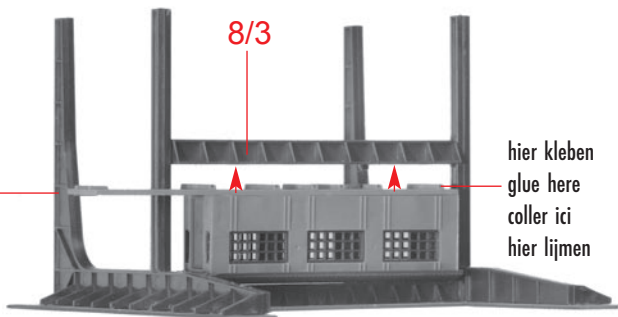

hier kleben
glue here
coller ici
hier lijmen

n

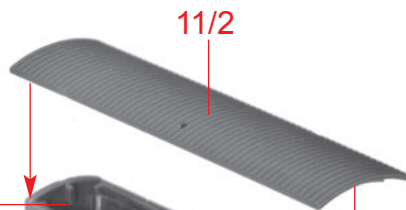

9/5

j

j

i

k

9/2

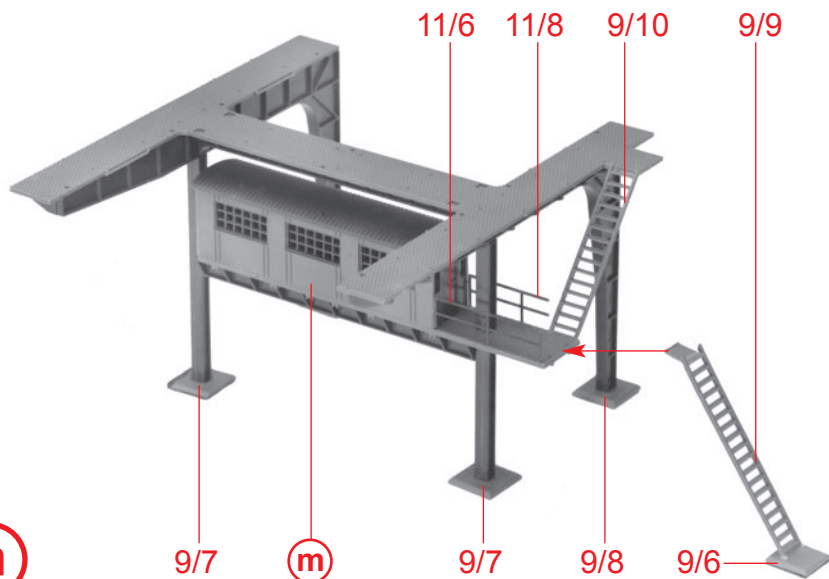

11/6

11/8

9/10

9/9

9/7

m

9/7

9/8

9/6

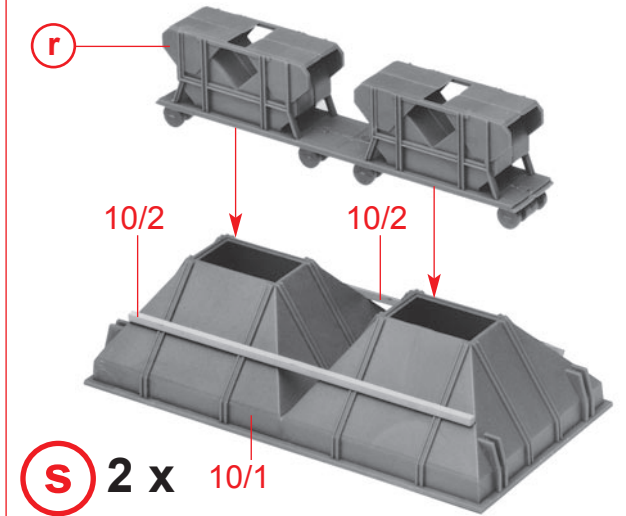
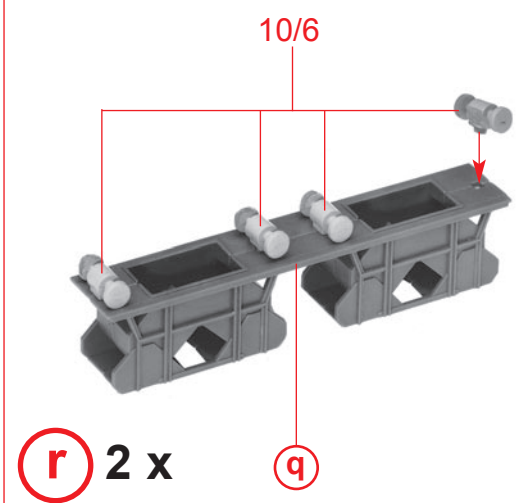
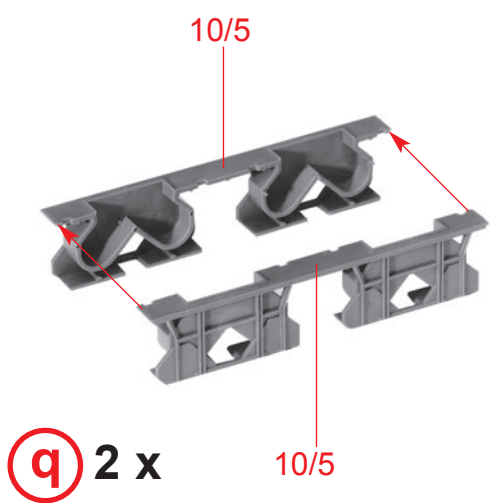
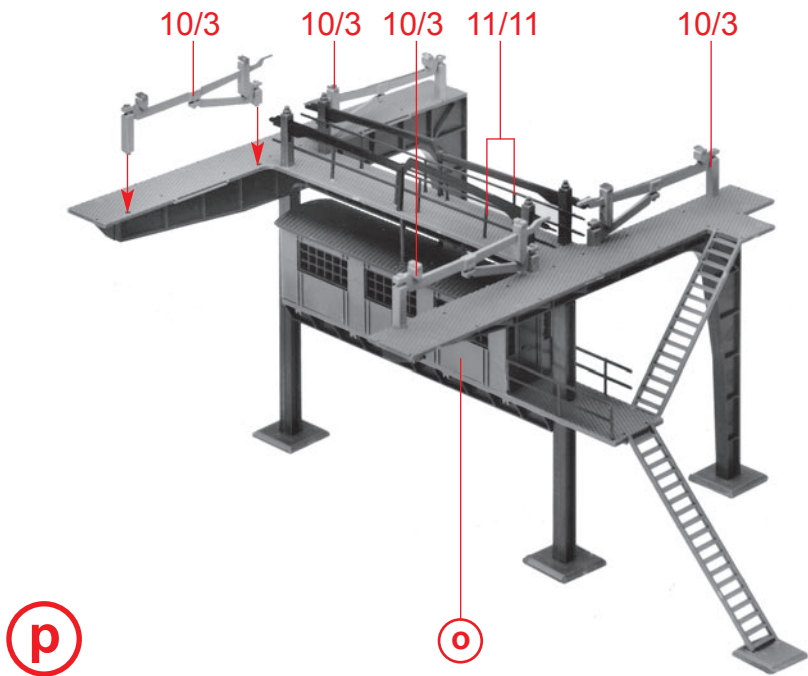
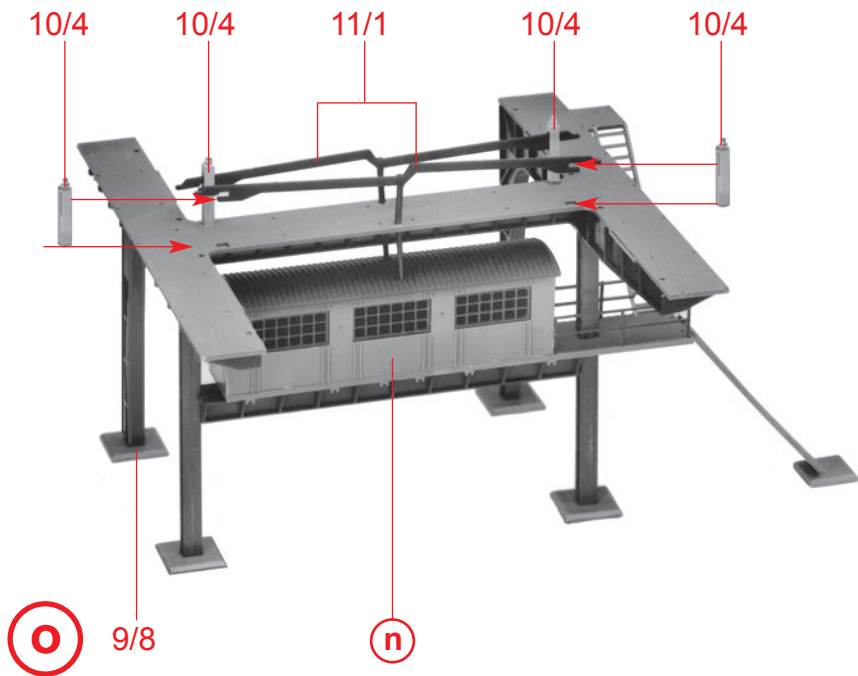

10

11/7

(s)

11/3

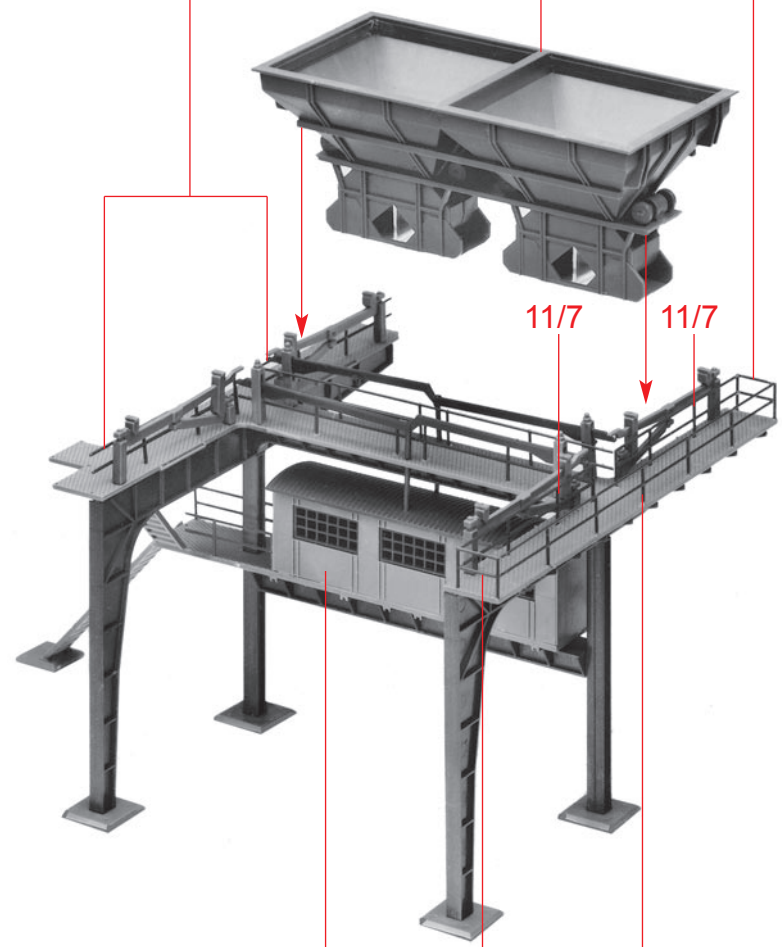

(t)

(p)

11/3

11/18

(u)

(t)

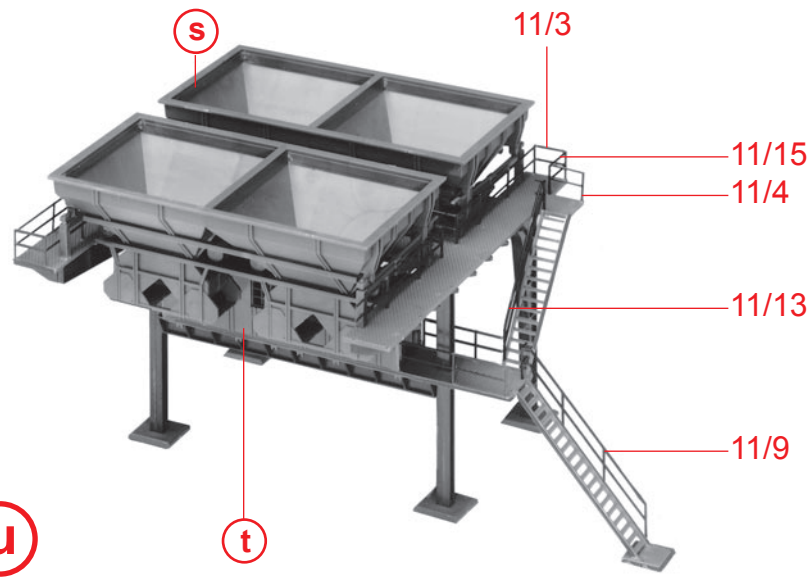

(v)

(u)

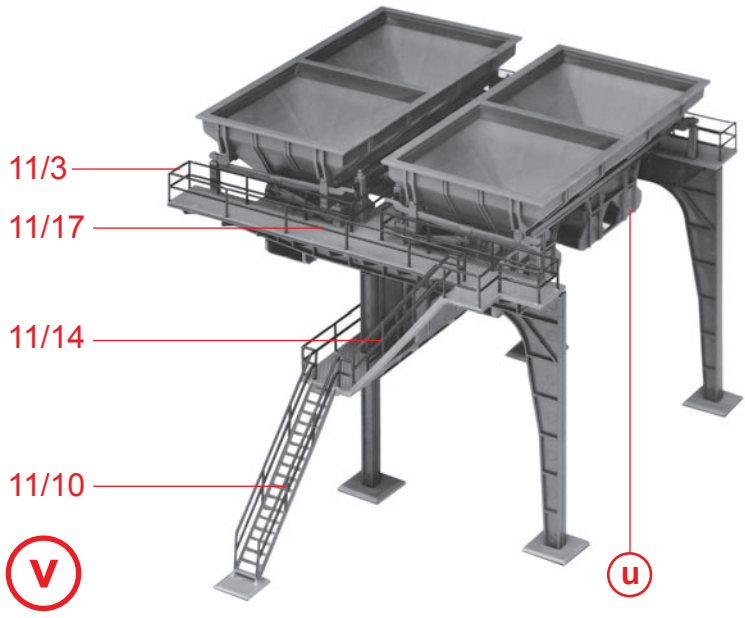

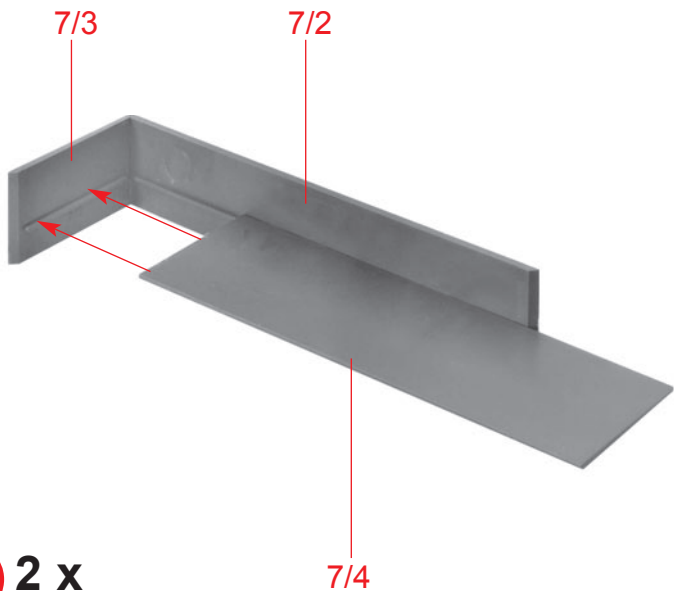

W 2 x

7/4

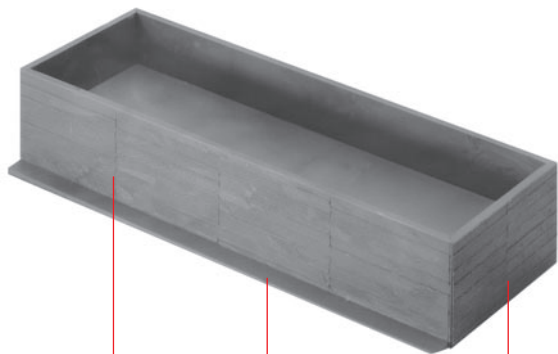

X 2 x

7/1

W

7/3

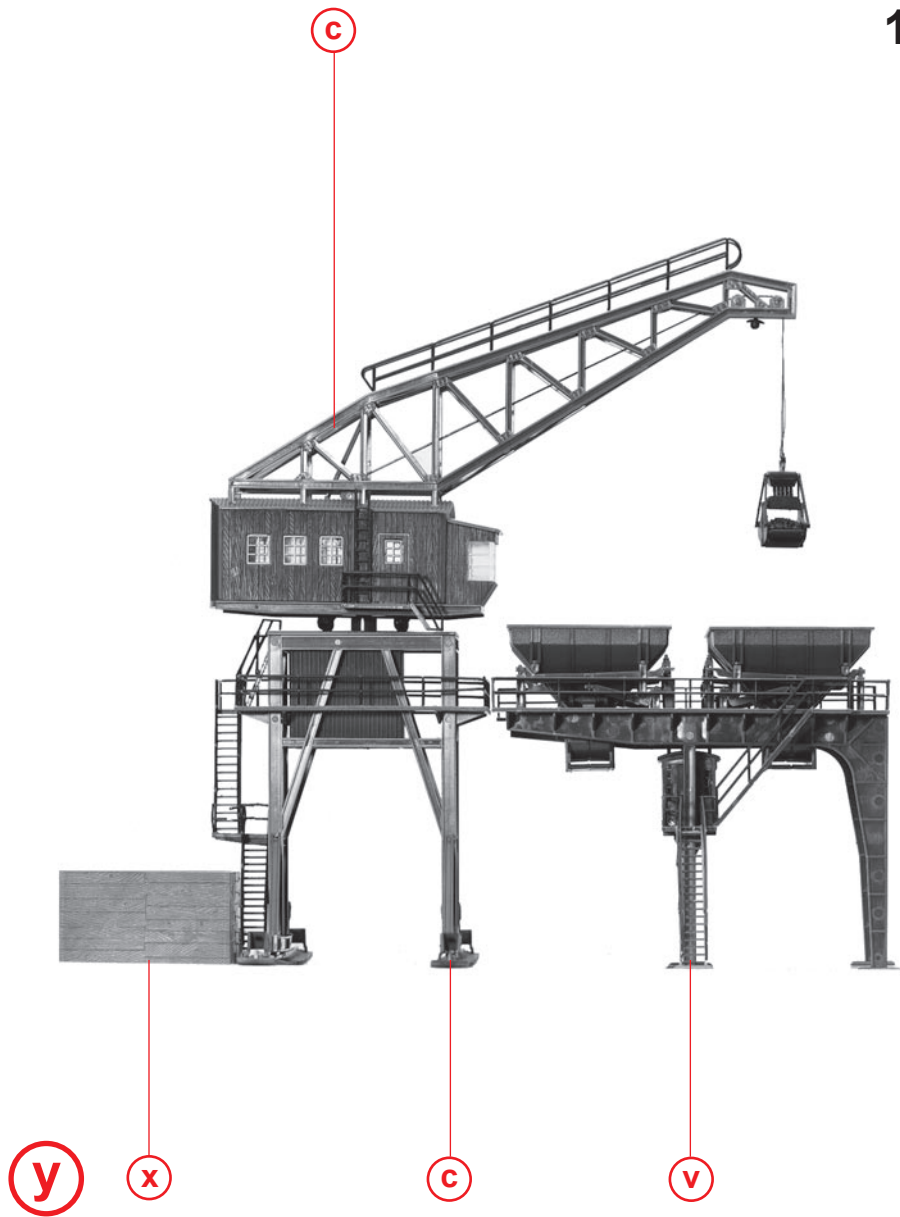

C

Y

X

C

V

Inhalt	Tüte	Contents	bag
Contenu	sachet	Inhoud	zakje

Inhalt	Tüte	Contents	bag
Contenu	sachet	Inhoud	zakje

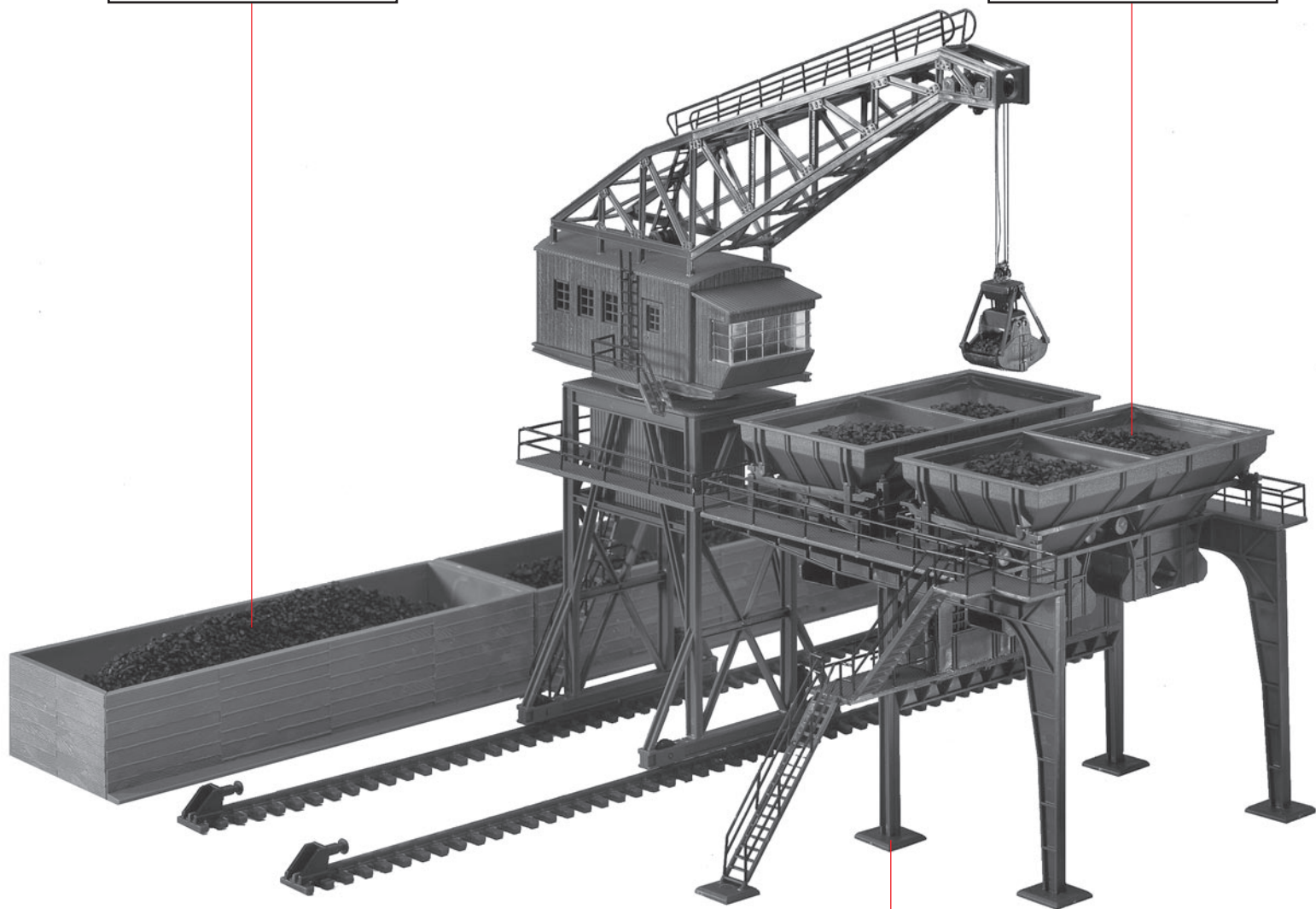
**Z****Y**