

BISTRO »WINTERGARTEN«

»WINTER GARDEN« BISTRO

CAFÉ »WINTERGARTEN«

BISTRO »WINTERTUIN«



Art. Nr. 130509

D

Machen Sie sich bitte vor Beginn des Bastelns mit dem Bausatzinhalt und der Anleitung vertraut und prüfen Sie die Vollständigkeit. Im Reklamationsfall gilt die gesetzliche Gewährleistungspflicht. Sollte ein Teil fehlen, übersenden Sie bitte den Teilwunsch und den Kaufbeleg an: Gebr. FALLER GmbH, Kundendienst, Kreuzstraße 9, D-78148 Gütenbach, kundendienst@faller.de. Sollten Sie einmal weitere Ersatzteile benötigen, senden wir Ihnen den benötigten Spritzling, bei Verfügbarkeit, gerne kostenpflichtig zu. Bitte beachten Sie, dass produktionsbedingt Einzelteile übrig bleiben können.

GB

Before building your model, please familiarize yourself with the contents of the kit and the instructions for use, also checking whether the set of parts is complete. In case of any complaint, the legal guarantee obligation shall apply. Should a part be missing, please send the designation of the part required and the receipt documenting your purchase to: Gebr. FALLER GmbH, Kundendienst, Kreuzstraße 9, D-78148 Gütenbach, kundendienst@faller.de. Should you require further spare parts one day, we shall be pleased to send you, with costs, the required sprue, if it is available. Please note that, on grounds of the production process, some single injection molded parts may be superfluous.

F

Avant de commencer votre modèle, veuillez vous familiariser avec le contenu du kit et la notice d'emploi, et contrôlez que le lot de pièces est complet. En cas de réclamation, il s'appliquera l'obligation de garantie légale. Au cas où une pièce manquerait, veuillez envoyer la désignation de la pièce souhaitée et le bon d'achat à: Gebr. FALLER GmbH, Kundendienst, Kreuzstraße 9, D-78148 Gütenbach, kundendienst@faller.de. Au cas où vous auriez besoin un jour d'autres pièces détachées, nous vous enverrons volontiers la grappe requise, si elle est disponible, contre paiement. Veuillez noter que, pour des raisons de production, il se peut que des pièces détachées soient superflues.

NL

Maak uzelf vóór het bouwen vertrouwd met de inhoud van het bouwpakket en met de handleiding en controleer de volledigheid. In geval van reclamatie geldt de wettelijke garantieverplichting. Mocht er een onderdeel ontbreken, stuur het verzoek om het gewenste onderdeel en het aankoopbewijs dan naar: Gebr. FALLER GmbH, Kundendienst, Kreuzstraße 9, D-78148 Gütenbach, kundendienst@faller.de. Als u ooit meer reserveonderdelen nodig hebt, sturen wij het benodigde gietstuk, indien beschikbaar, graag tegen betaling naar u op. Let op: om productieredenen kunnen losse onderdelen overblijven.

Für den Zusammenbau des Modells empfehlen wir folgende FALLER-Artikel (sind nicht im Bausatz enthalten):

For the assembly of the kit we recommend following FALLER products (not included in the kit):

Pour l'assemblage du modèle, nous vous recommandons les articles FALLER suivants (non inclus dans le kit):

Om dit model te bouwen adviseren wij de volgende FALLER producten (maken geen deel uit van deze bouwset):

Art. Nr. 170490 | 170492 | 170494
FALLER SUPER-EXPERT | EXPERT | LASERCUT



Art. Nr. 170688
SPEZIAL-SEITENSCHNEIDER



Art. Nr. 170687
FALLER-BASTELMESSER

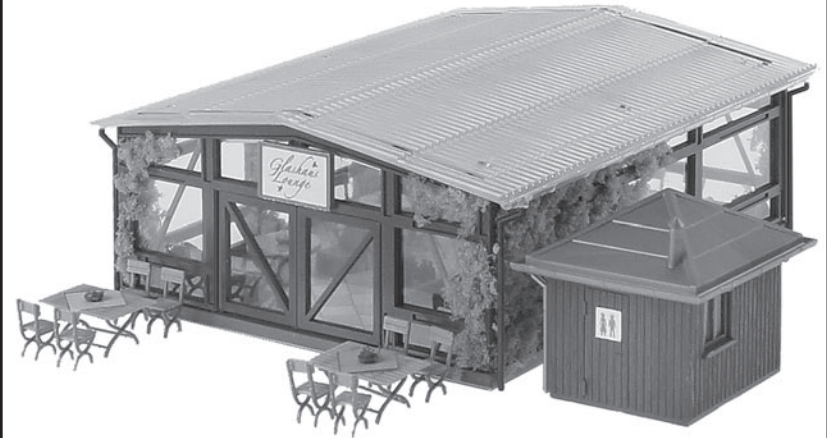

Inhalt	Spritzlinge	3	1 x	25 A	4 x	3	1 x
Contents	Sprues	4	1 x	25 B	2 x	3	1 x
Contenu	Moulages	5	1 x	2	1 x	8	1 x
Inhoud	Gietstukken						

Sa. Nr. 130 509 1

2 Praktischer Tipp zum Anbringen der Fensterfolie:

Die Fensterfolie genau ausschneiden und den zu beklebenden Fensterrahmen mit Klebstoff (FALLER Expert) benetzen.

Dann mit einem Stück zerknülltem Zellstoff (Toilettenpapier oder ähnlichem) vorsichtig abtupfen und anschließend die Fensterfolie exakt auflegen. Verschieben der geklebten Fensterfolie vermeiden. Durch das Abtupfen wird eine gewisse Menge des Klebstoffes aufgesogen und die Klebestelle trocknet schneller ab. Diese Technik wirkt dem Kapillareffekt entgegen.

Practical tip for application of the window foil:

Cut the window foil thoroughly and moisten the window frame with glue (FALLER Expert).

Then dab with a piece of cellulose (toilet paper or similar) and attach the window foil exactly. Avoid moving the glued window foil.

Dabbing soaks up part of the glue and the glued part dries quicker. This procedure works against the capillary action.

Astuce pour l'application de la feuille de décalcomanie:

Découper soigneusement la feuille de décalcomanie, humecter la zone à coller en utilisant la colle FALLER EXPERT.

A l'aide d'un essuie tout tamponner délicatement le surplus de colle et appliquer avec exactitude la feuille de décalcomanie dans le cadre. Eviter de déplacer la feuille de décalcomanie après encollage .

Par le fait de tamponner la zone à encoller le surplus de colle sera absorbé, donc la zone à coller séchera plus vite. Cette technique agit contre l'effet de capillarité.

Praktisch tip voor het aanbrengen van de vensterfolie:

De vensterfolie op maat snijden en de te beplakken vensterramen voorzichtig met lijm (FALLER Expert) insmeren.

Dan met een stuk celstof (toilet papier of iets dergelijks) voorzichtig afbetten en vervolgens de vensterfolie op de exacte plek bevestigen. Vermijd het verschuiven van de folie.

Door het afbetten wordt een bepaalde hoeveelheid van de lijm opgezogen waardoor de lijmplek sneller droogt. Deze techniek gaat het capillaire effect tegen.

Decobogen aufziehen !

1. In einem flachen Teller eine Lauge aus Wasser mit 2 Tropfen Geschirrspülmittel ansetzen.
2. Schutzpapier von der Folie abziehen.
3. Folie mit der Klebeseite nach unten durch die Lauge ziehen.
4. Benetzte Folie auf die Oberseite der angegebenen Teile legen und ausrichten.
5. Mit einer Gummwalze, Spachtel oder weichem Tuch blasenfrei anreiben.
6. Gut durchtrocknen lassen !

Montage de la feuille de décoration !

1. Dans une assiette plate préparer une lessive avec de l'eau et 2 gouttes d'agent de lavage de vaisselle.
2. Retirer le papier de protection de la feuille.
3. Tirer la feuille, la face adhésive tournée vers le bas, à travers la lessive.
4. Placer la feuille humidifiée sur la face supérieure des éléments en question et l'aligner.
5. L'appliquer sans soufflures avec un rouleau en caoutchouc, une spatule ou un chiffon moux.
6. Laisser bien sécher.

Fitting the decoration sheet !

1. Use a flat plate and prepare a solution of water with two drops of dish-washing agent.
2. Pull off protective paper from sheet.
3. Pull sheet with its adhesive side down through the solution.
4. Place wetted sheet on the top of the specified parts and align it.
5. Rub it with a rubber roller, a putty knife or a soft cloth until it is bubble-free.
6. Allow it to dry well.

Decoblad aanbrengen !

1. Neem een plat bord, doe daarop voldoende water en 2 druppels afwasmiddel.
2. Schutpapier van folie afnemen.
3. Folie met de lijmkant naar beneden door het water halen.
4. De natgemaakte folie op de bovenkant van de aangegeven delen leggen en op de juiste plaats schuiven.
5. Luchtballen wegdrukken of wegwrijven met een zacht dockje, rubberrol of spatel.
6. Heel goed laten drogen.

4/4

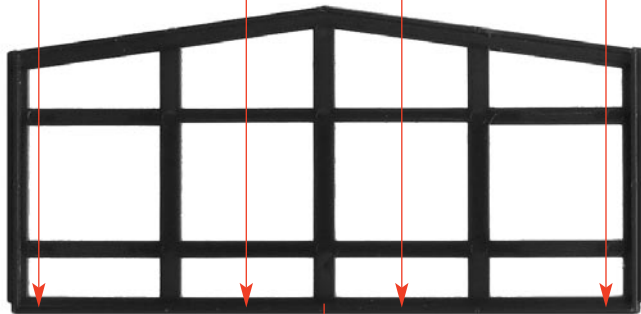
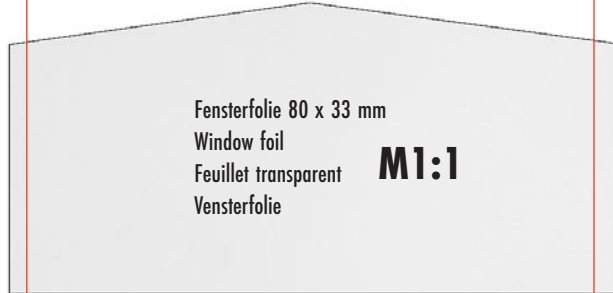
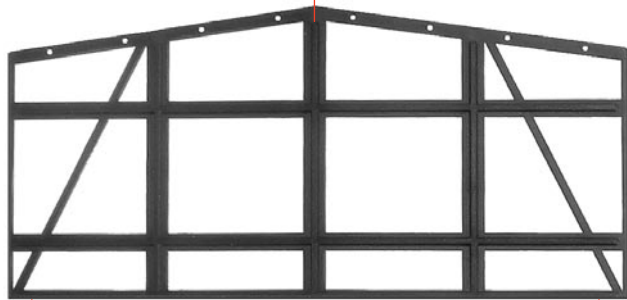

4/3

A

4/6

3

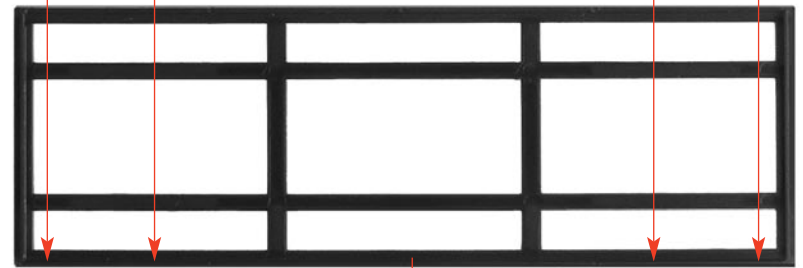
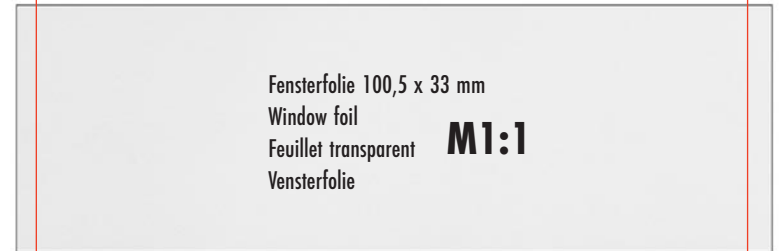
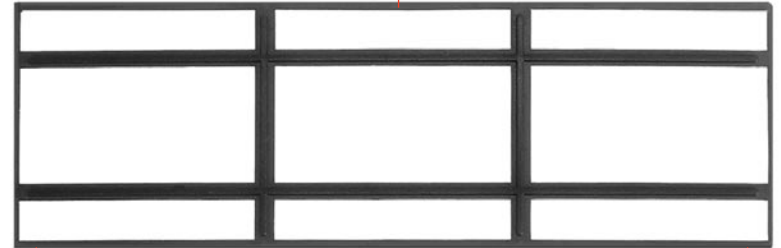

4/5

B 2 x

4

Fensterfolie 80 x 33 mm
Window foil
Feuillet transparent
Vensterfolie

M1:1



4/1

C

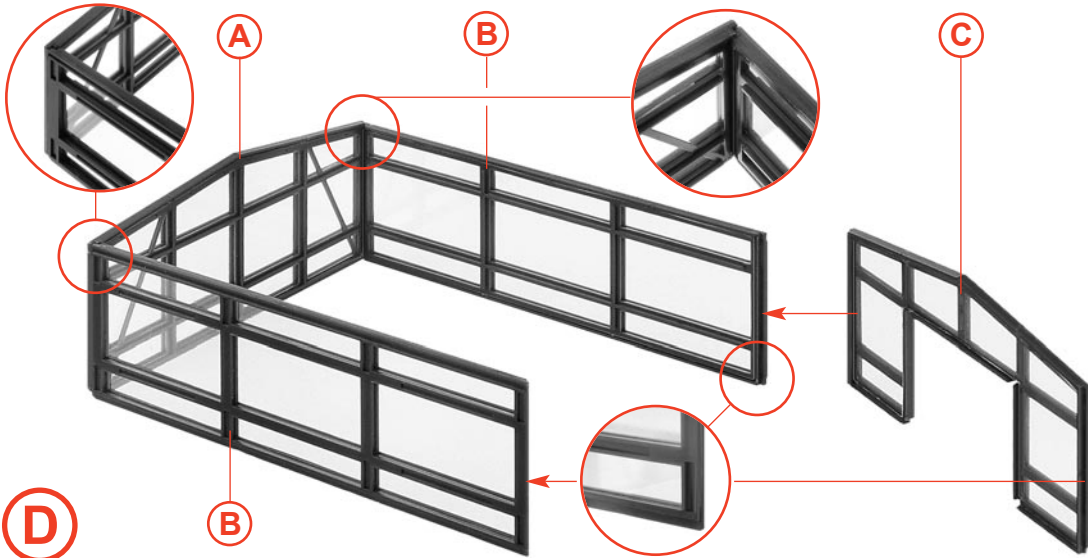

D

B

Deco 1

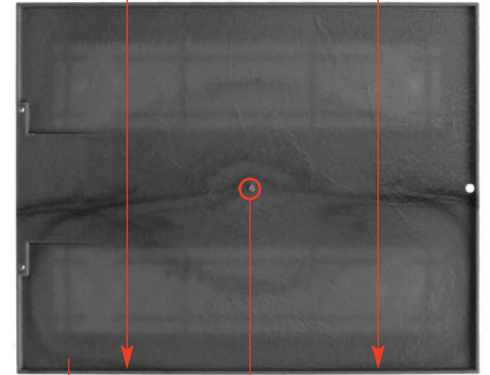
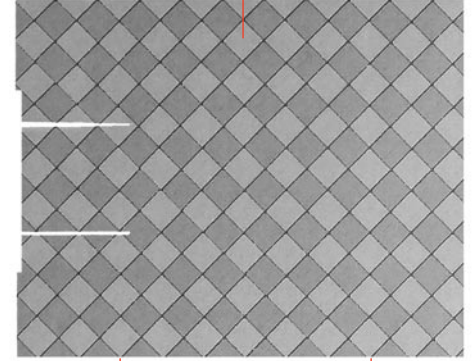

3/1

Abtrennen
Separate
Séparer
Afknippen

E

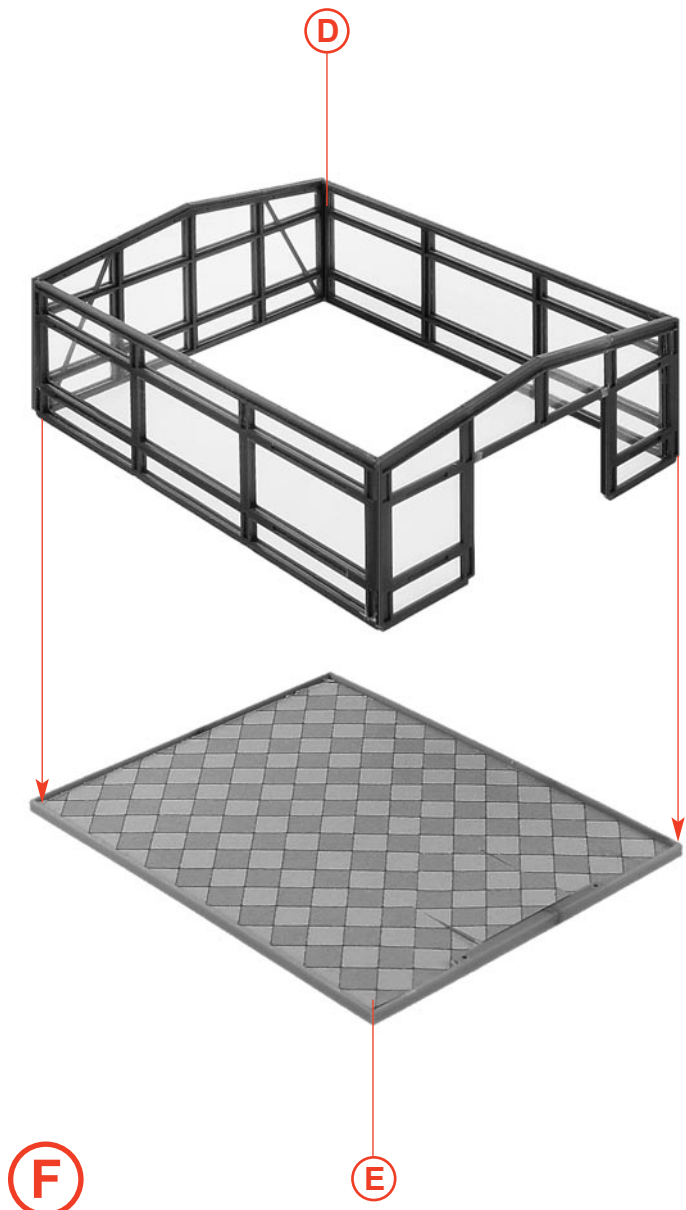

Fensterfolie 16,5 x 21 mm
Window foil
Feuillet transparent
Vensterfolie

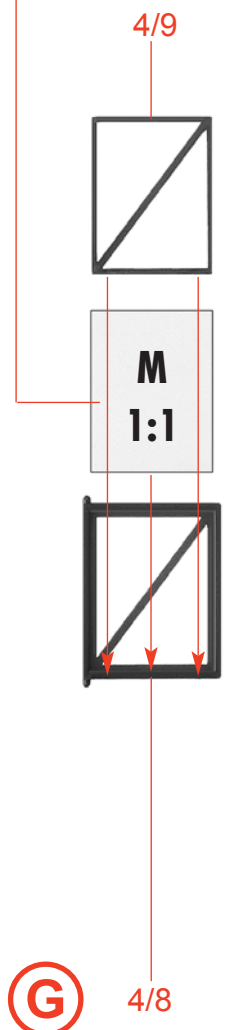

Fensterfolie 16,5 x 21 mm
Window foil
Feuillet transparent
Vensterfolie

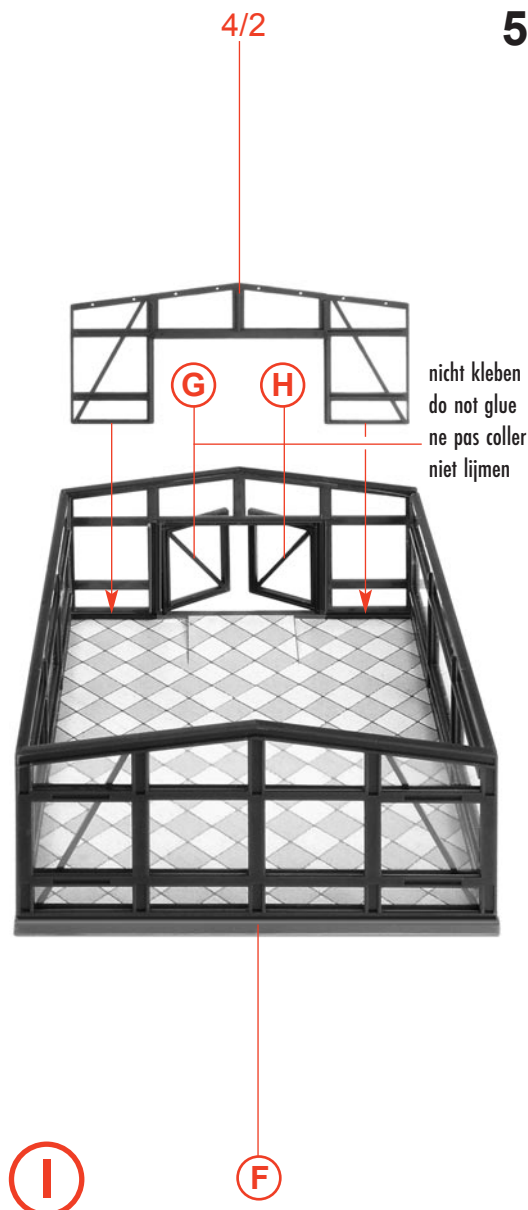
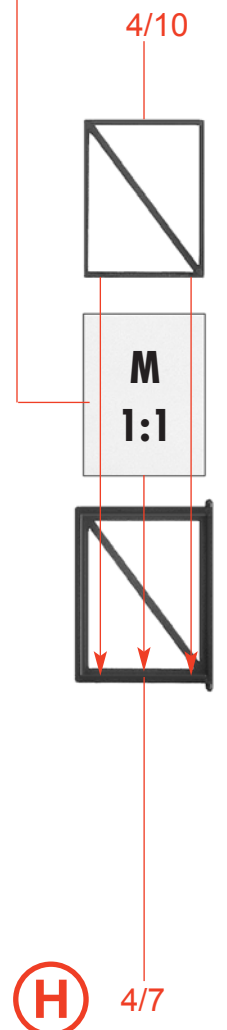

6

Deco 9

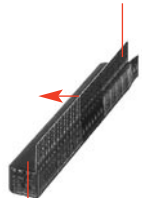

J 3 x 8/29

K 3 x **J**



L 3 x **K**

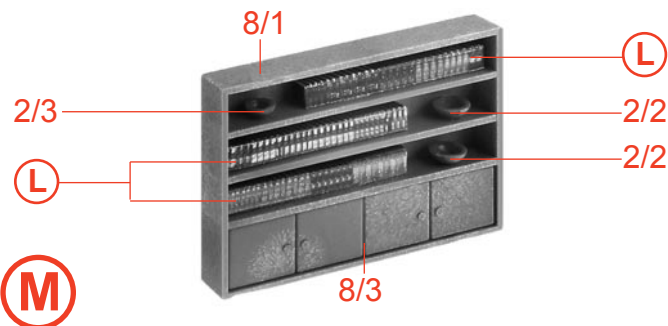

M

8/18 Deco 10

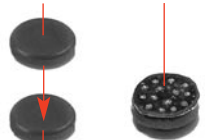

N 8/18

8/20 Deco 11

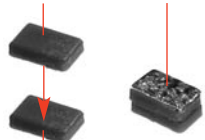

O 8/20

8/19



P 2/4

Inhalt	Tüte	Contents	bag
Contenu	sachet	Inhoud	zakje

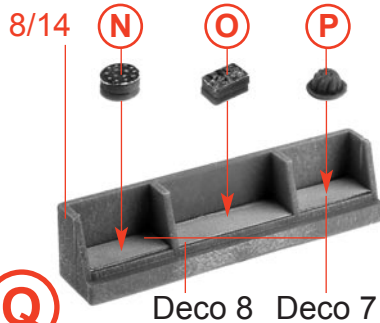
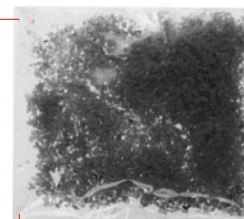

Q Deco 8 Deco 7

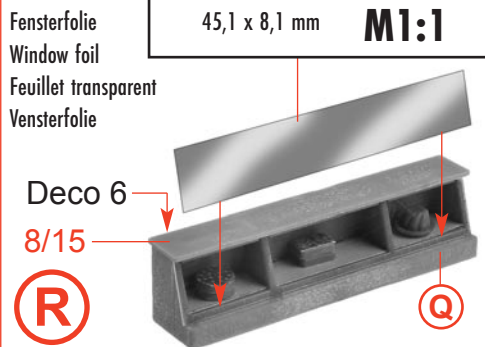

R Deco 6 8/15 **Q**

45,1 x 8,1 mm **M1:1**

Fensterfolie
Window foil
Feuillet transparent
Vensterfolie

Deco 13



S 8/16

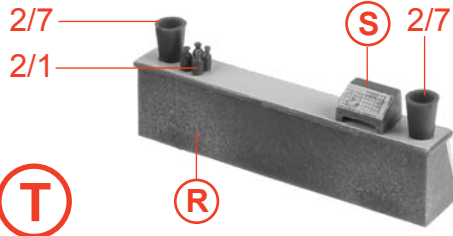

T 2/7 2/1 **S** 2/7 **R**



U 8/26

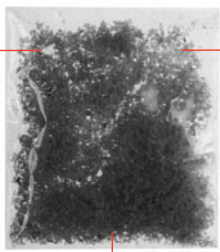
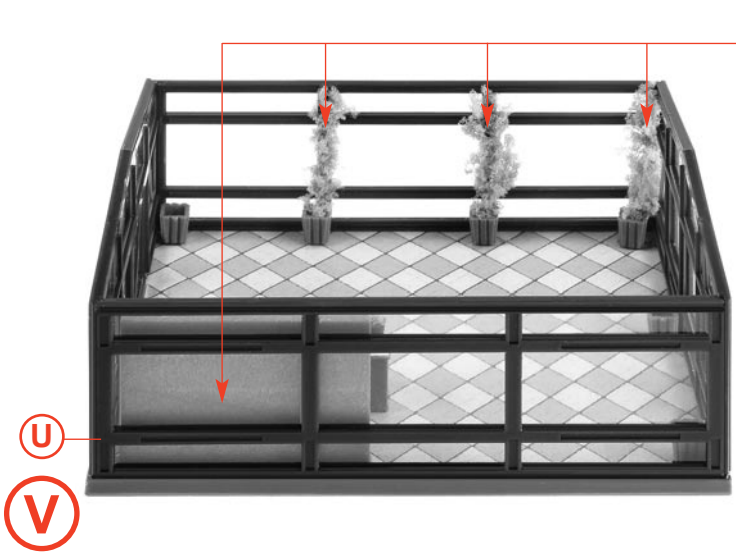

Inhalt	Tüte
Contents	bag
Contenu	sachet
Inhoud	zakje



U
V

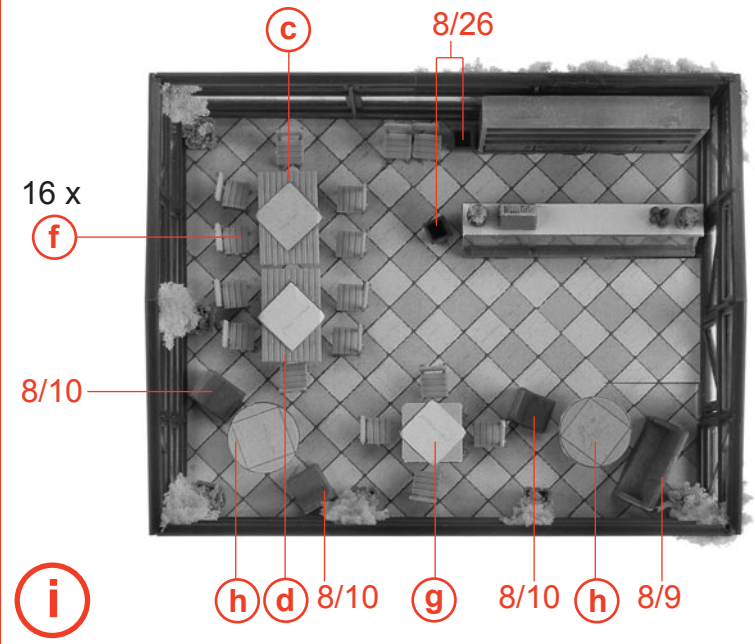
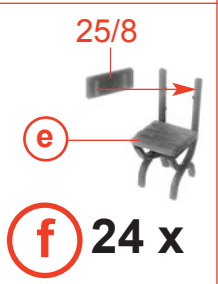
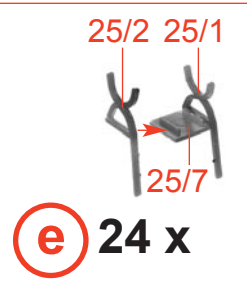
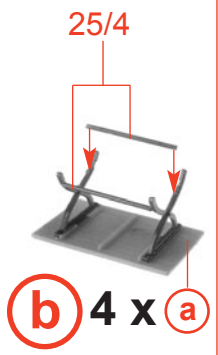
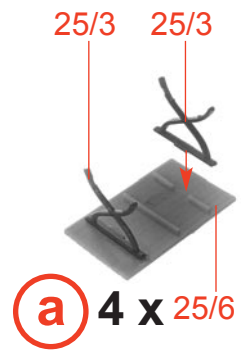

8 Inhalt Tüte
 Contents bag
 Contenu sachet
 Inhoud zakje

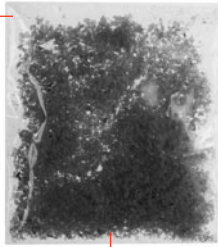

2 x
 2/6
 4 x
 2/5

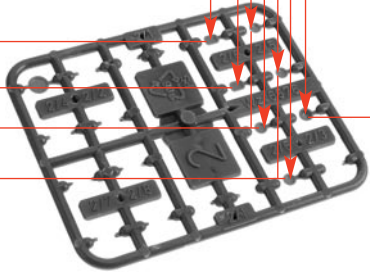

2/3

j

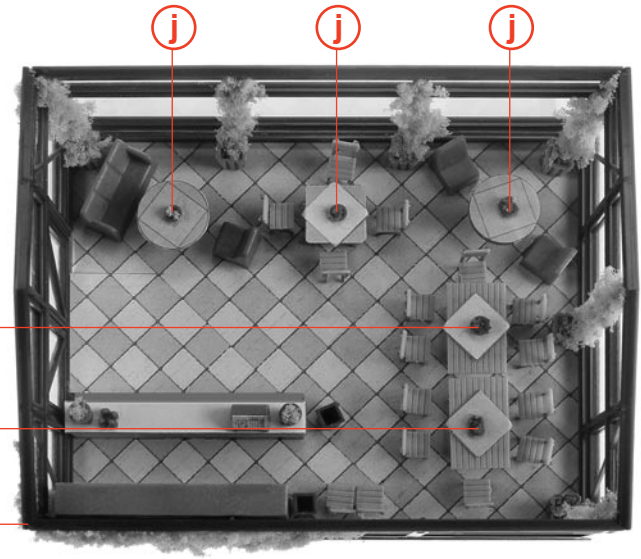

j

j

k

i

l 8 x



Papiermaske
 Papermask
 Masque
 Masker **M1**

l

m 4 x

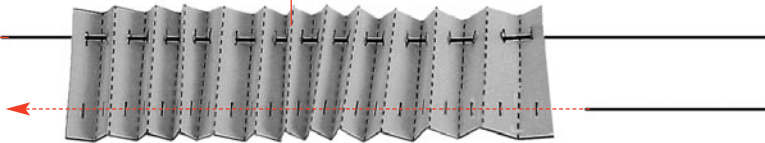

l



m



Sekundenkleber (FALLER EXPERT rapid 170500) verwenden.
 Use instant modelling cement (FALLER EXPERT rapid 170500).
 Utilisez la colle rapide (FALLER EXPERT rapid 170500).
 Gebruik secondenlijm (FALLER EXPERT rapid 170500).

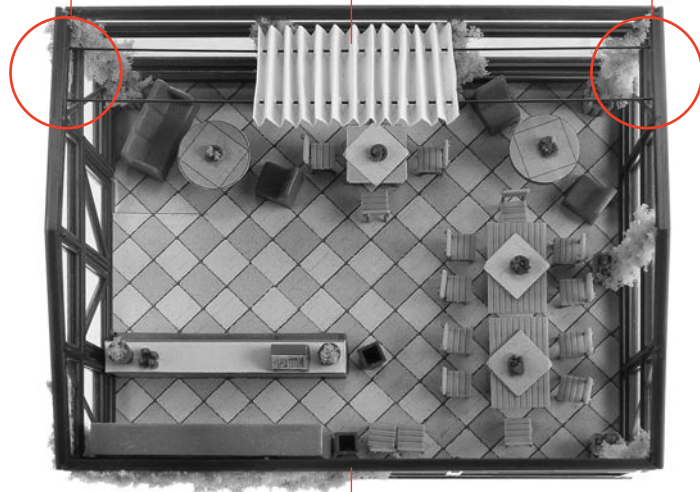

n

k

m

Sekundenkleber (FALLER EXPERT rapid 170500) verwenden.
 Use instant modelling cement (FALLER EXPERT rapid 170500).
 Utilisez la colle rapide (FALLER EXPERT rapid 170500).
 Gebruik secondenlijm (FALLER EXPERT rapid 170500).

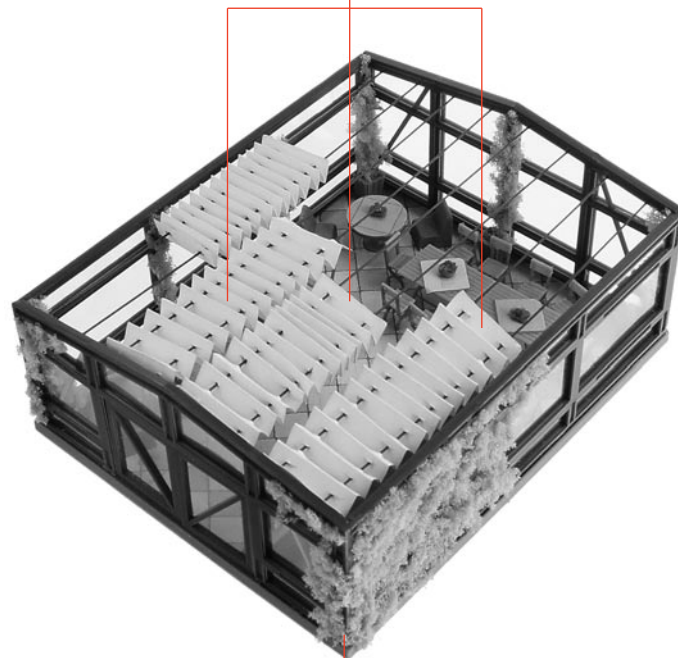

o

n

10

Deco 12

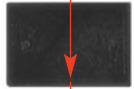

8/6

p

5/7

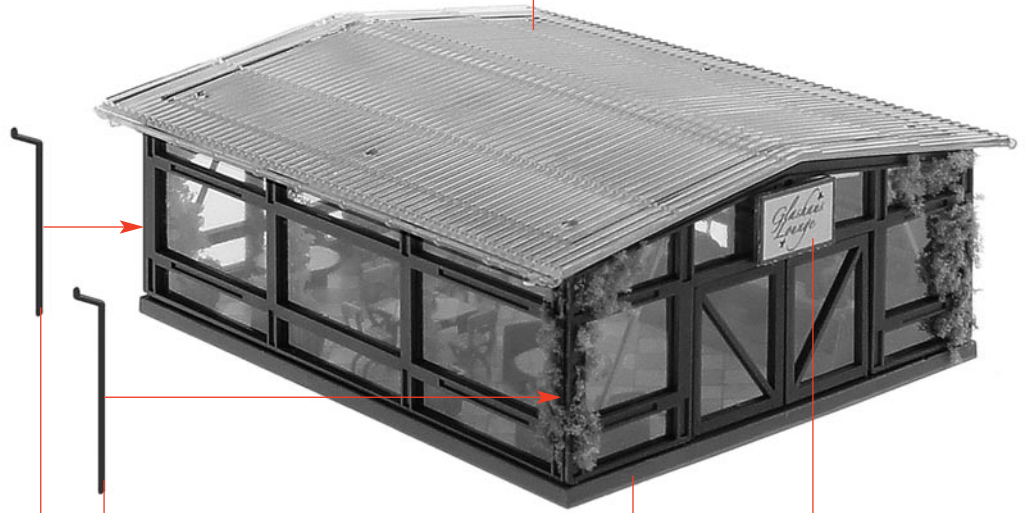

q

4/12

o

p

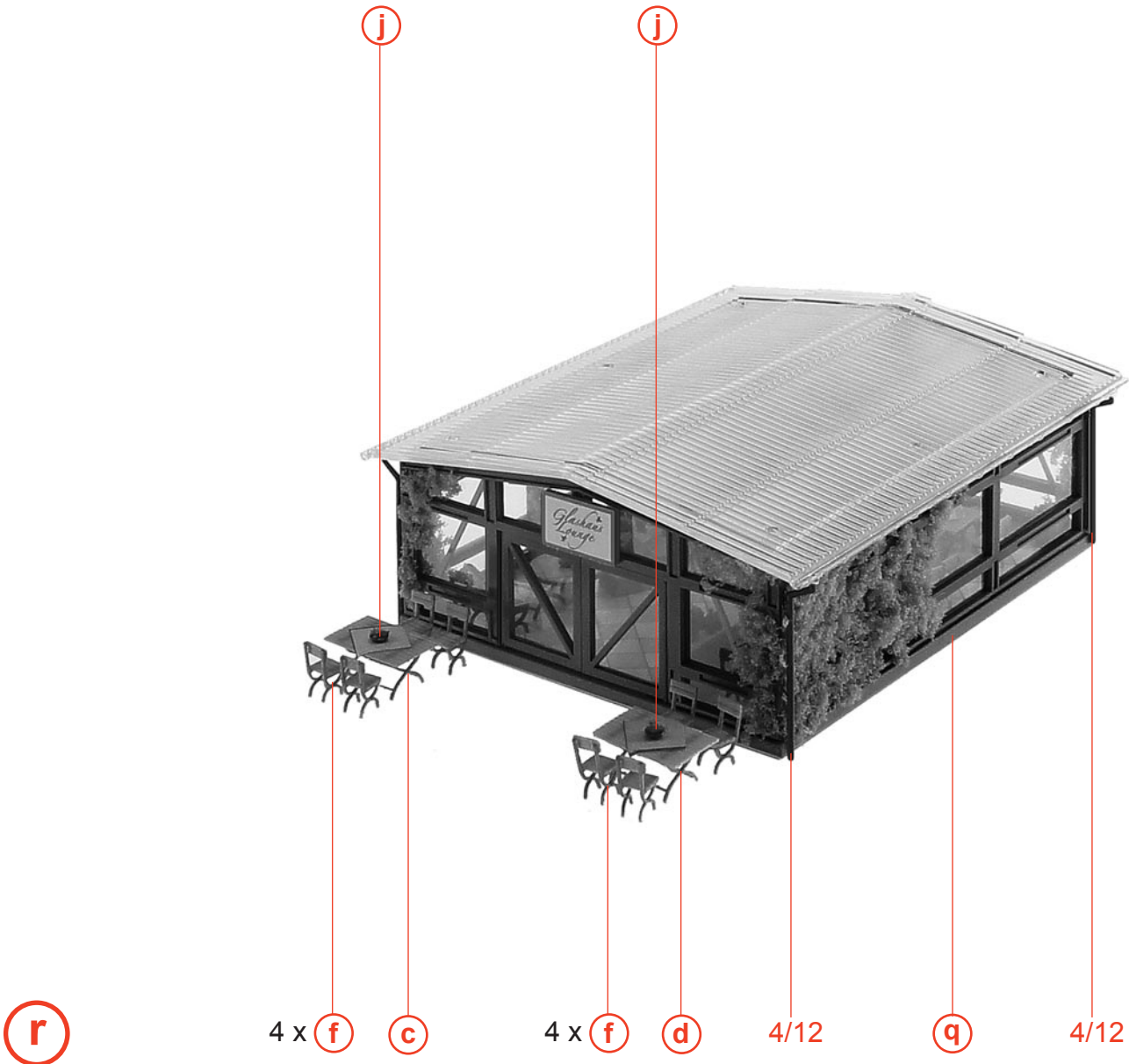

j

j

r

4 x

f

c

4 x

f

d

4/12

q

4/12

12

Deco 15

Fensterfolie
Window foil
Feuillet transparent
Vensterfolie

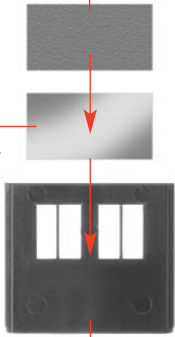

grün
green
vert
groen

3/4

S

Deco 16

Fensterfolie
Window foil
Feuillet transparent
Vensterfolie

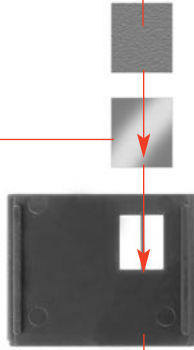

grün
green
vert
groen

3/2

t

s

t

3/3

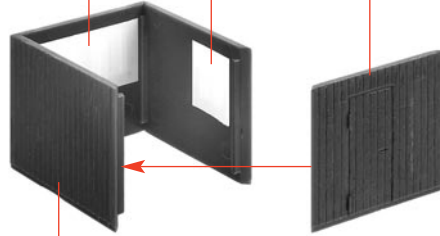

u 3/1

silber
silver
argent
zilver

3/5

3/6



v 3/7

u Deco 14

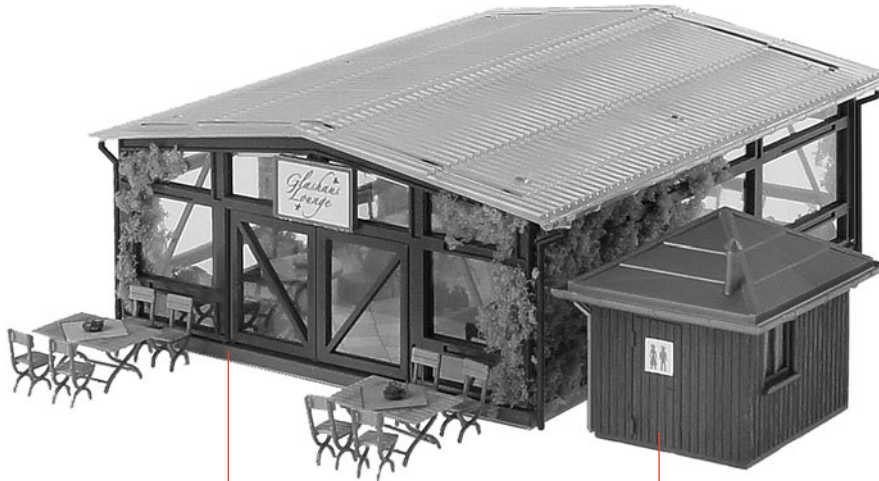

w

r

v