

# JAGDSCHLOSS »BELLEVUE«

»BELLEVUE« HUNTING LODGE  
PAVILLON DE CHASSE »BELLEVUE«  
JACHTHUIS »BELLEVUE«

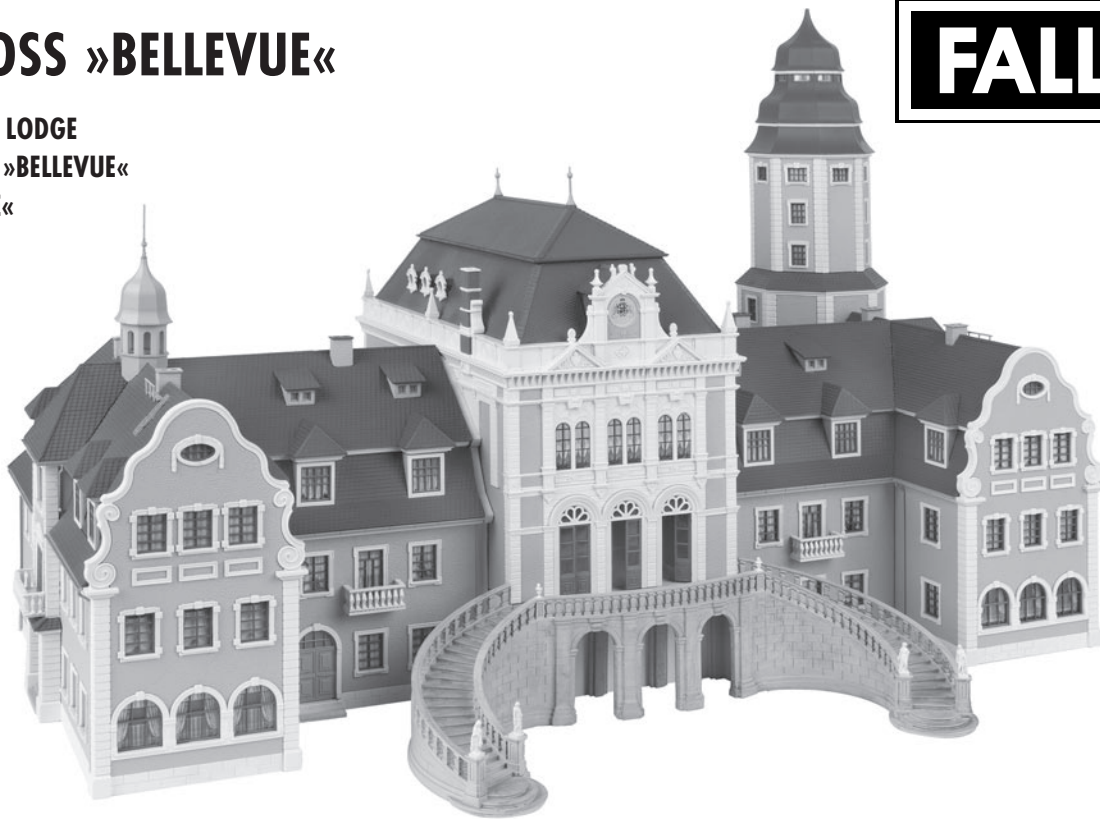

Art. Nr. 130830



<b>Inhalt</b>	Spritzlinge/TR	1	1 x	4	2 x	TR 10	1 x	17	2 x	19 A	1 x	21	1 x	23	2 x	26	2 x
<b>Contents</b>	Sprues/TR	2	2 x	5	2 x	TR 11	1 x	17 D	1 x	19 AB	1 x	22	1 x	23	2 x	27	3 x
<b>Contenu</b>	Grappes/TR	2	2 x	6	2 x	13	2 x	18	1 x	20	1 x	22 A	1 x	24	1 x	28	1 x
<b>Inhoud</b>	Gietstukken/TR	3	2 x	8 AB	2 x	14	2 x	18	1 x	20	2 x	22 AB	1 x	24	1 x	31	1 x
		3	4 x	TR 9	1 x	15	2 x	19	1 x	21	1 x	23	1 x	25	1 x		

Sa. Nr. 130 830 2

**D** Machen Sie sich bitte vor Beginn des Bastelns mit dem Bausatzinhalt und der Anleitung vertraut und prüfen Sie die Vollständigkeit. Im Reklamationsfall gilt die gesetzliche Gewährleistungspflicht. Sollte ein Teil fehlen, übersenden Sie bitte den Teilwunsch und den Kaufbeleg an: Gebr. FALLER GmbH, Kundendienst, Kreuzstraße 9, D-78148 Gütenbach, kundendienst@faller.de. Sollten Sie einmal weitere Ersatzteile benötigen, senden wir Ihnen den benötigten Spritzling, bei Verfügbarkeit, gerne kostenpflichtig zu. Bitte beachten Sie, dass produktionsbedingt Einzelteile übrig bleiben können.

**GB** Before building your model, please familiarize yourself with the contents of the kit and the instructions for use, also checking whether the set of parts is complete. In case of any complaint, the legal guarantee obligation shall apply. Should a part be missing, please send the designation of the part required and the receipt documenting your purchase to: Gebr. FALLER GmbH, Kundendienst, Kreuzstraße 9, D-78148 Gütenbach, kundendienst@faller.de. Should you require further spare parts one day, we shall be pleased to send you, with costs, the required sprue, if it is available. Please note that, on grounds of the production process, some single injection molded parts may be superfluous.

**F** Avant d'assembler votre modèle veuillez d'abord vous familiariser avec le contenu du kit et vérifier que le lot de pièces soit complet. En cas de réclamation la garantie légale s'appliquera. Au cas où une pièce manquerait, veuillez envoyer la désignation de la pièce souhaitée et le bon d'achat à: Gebr. FALLER GmbH, Kundendienst, Kreuzstraße 9, D-78148 Gütenbach, kundendienst@faller.de. Au cas où vous auriez besoin un jour d'autres pièces détachées, nous vous enverrons volontiers la grappe requise, si elle est disponible, contre paiement. Veuillez noter que, pour des raisons de production, il se peut que des pièces détachées soient superflues.

**NL** Maak uzelf vóór het bouwen vertrouwd met de inhoud van het bouwpakket en met de handleiding en controleer de volledigheid. In geval van reclamatie geldt de wettelijke garantieverplichting. Mocht er een onderdeel ontbreken, stuur het verzoek om het gewenste onderdeel en het aankoopbewijs dan naar: Gebr. FALLER GmbH, Kundendienst, Kreuzstraße 9, D-78148 Gütenbach, kundendienst@faller.de. Als u ooit meer reserveonderdelen nodig hebt, sturen wij het benodigde gietstuk, indien beschikbaar, graag tegen betaling naar u op. Let op: om productieredenen kunnen losse onderdelen overblijven.

Für die Montage benötigen Sie Plastik-Klebstoff und Expert Lasercut-Kleber.

Wir empfehlen:

FALLER-Klebstoff EXPERT (Art. Nr. 170492)  
FALLER-Klebstoff EXPERT-Lasercut (Art. Nr. 170494)  
FALLER-Sekundenkleber EXPERT RAPID (Art. Nr. 170500)  
FALLER-Spezial-Seitenschneider (Art. Nr. 170688)  
FALLER-Bastelmesser (Art. Nr. 170687)

For mounting you need plastic cement and Lasercut cement.

Our recommendation:

FALLER cement EXPERT (Art. No. 170492)  
FALLER cement EXPERT-Lasercut (Art. No. 170494)  
FALLER instant modelling cement EXPERT RAPID (Art. Nr. 170500)  
FALLER special side cutter (Art. No. 170688)  
FALLER modeller's knife (Art. No. 170687)

Pour le montage, utiliser de la colle plastique et de la colle Lasercut.

Nous vous recommandons les produits suivants:

Colle FALLER EXPERT (Art. Nr. 170492)  
Colle FALLER EXPERT-Lasercut (Art. Nr. 170494)  
Colle rapide EXPERT RAPID (Art. Nr. 170500)  
Pince coupante diagonale spéciale FALLER (Art. Nr. 170688)  
Couteau de bricolage FALLER (Art. Nr. 170687)

Voor de montage heeft u plasticlijm en Lasercut lijm nodig.

Wij adviseren:

FALLER-plasticlijm EXPERT (Art. Nr. 170492)  
FALLER-Lasercut lijm (Art. Nr. 170494)  
FALLER-Secondenlijm EXPERT RAPID (Art. Nr. 170500)  
FALLER-speciaal zijknijptang (Art. Nr. 170688)  
FALLER-knutselmes (Art. Nr. 170687)

Art. Nr. 170490 | 170492 | 170494  
FALLER SUPER-EXPERT | EXPERT | LASERCUT



Art. Nr. 170688  
SPEZIAL-SEITENSCHNEIDER



Art. Nr. 170687  
FALLER-BASTELMESSER



**2** Fensterfolie: Das abgebildete Papier-Musterfenster mit transparentem Klebeband auf die beiliegende Fensterfolie kleben und diese ausschneiden.  
Fensterfolie vorsichtig mit wenig Klebstoff auf die Rückseite der Fensterrahmen aufkleben.

Window plastic sheet: Using clear adhesive tape fix the pattern window made of paper pictured to the window plastic sheet supplied, and cut that sheet out.  
Using very little glue, cautiously stick the window sheet to the back of the window frame.

Feuille transparente pour fenêtres : À l'aide de ruban adhésif transparent coller la fenêtre à dessin en papier représentée sur la feuille transparente fournie, et découper cette feuille.  
Coller avec précaution la feuille transparente, avec très peu de colle, au dos du cadre de la fenêtre.

Raamfolie: De afgebeelde papieren raamdecoratie met transparant plakband op de meegeleverde raamfolie plakken en uitknippen. Raamfolie voorzichtig met een beetje lijm op de achterzijde van de ramen lijmen.

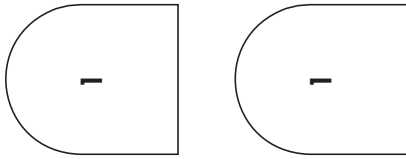

4	4	4	4	4	4
4	4	4	4	4	4

5	5	5
---	---	---

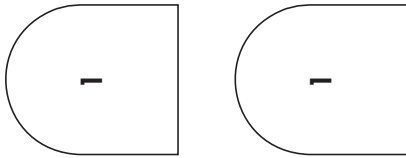

6	6	6	6	6	6	6	6	6	6
6	6	6	6	6	6	6	6	6	6
6	6	6	6	6	6	6	6	6	6
6	6	6	6	6	6	6	6	6	6

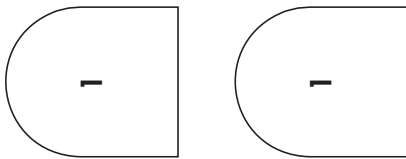

2	2
2	2



4	4	4	4	4	4
4	4	4	4	4	4

5	5	5
---	---	---

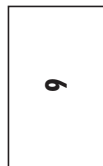
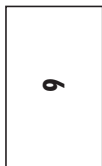

6	6	6	6	6	6	6	6	6	6
6	6	6	6	6	6	6	6	6	6
6	6	6	6	6	6	6	6	6	6
6	6	6	6	6	6	6	6	6	6

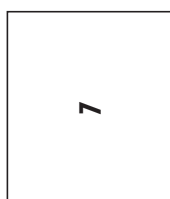
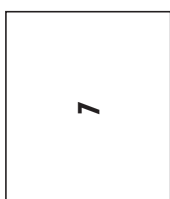
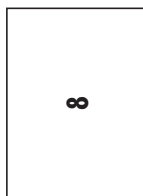
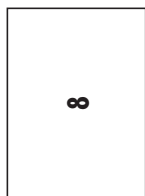

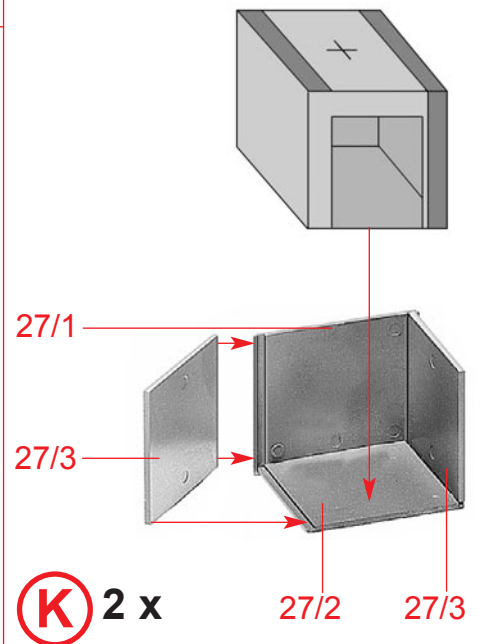
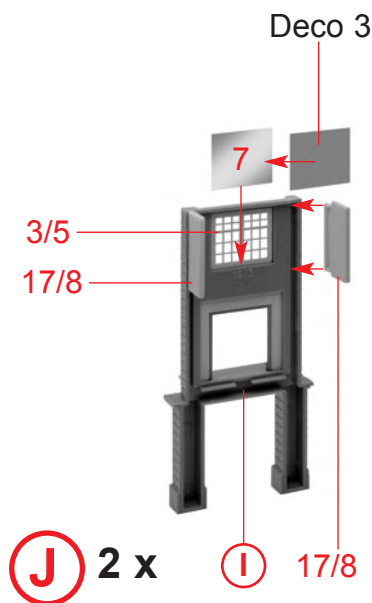
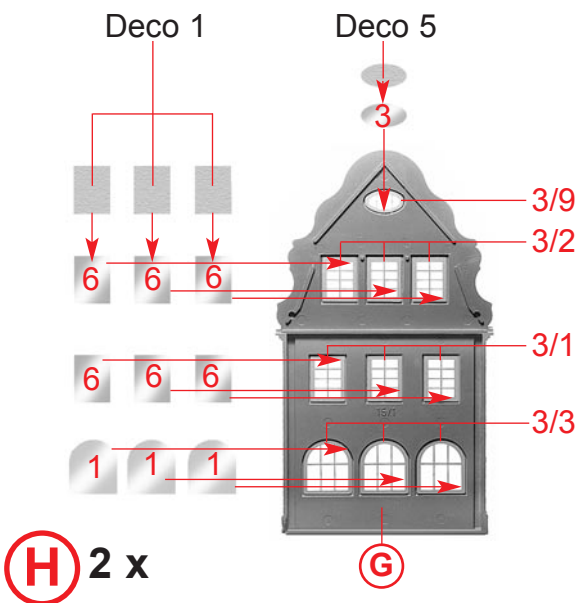
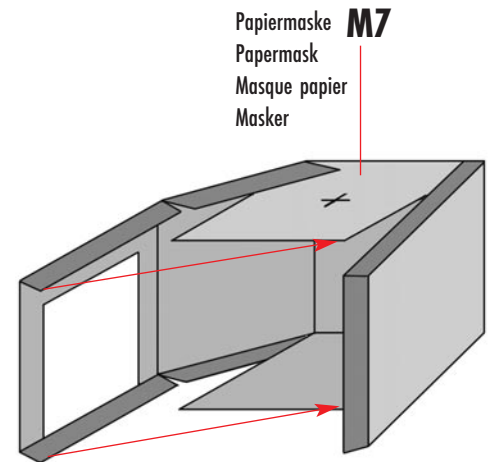
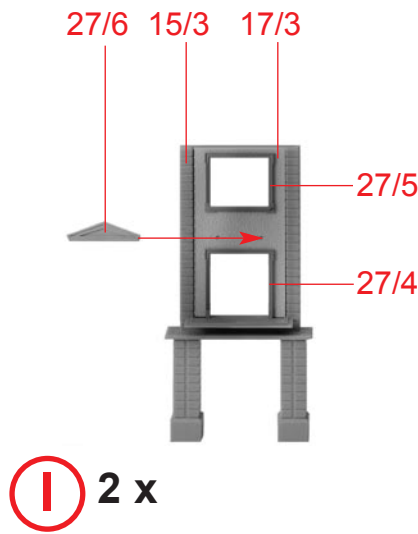
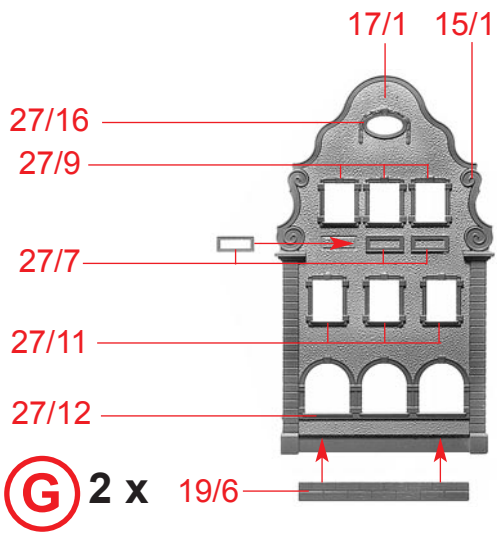
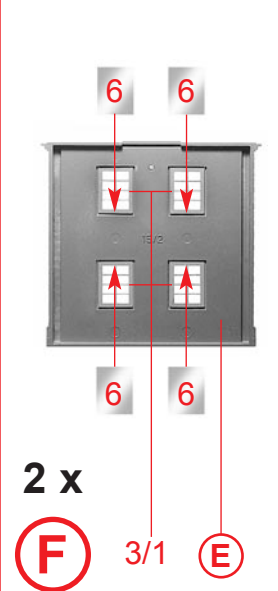
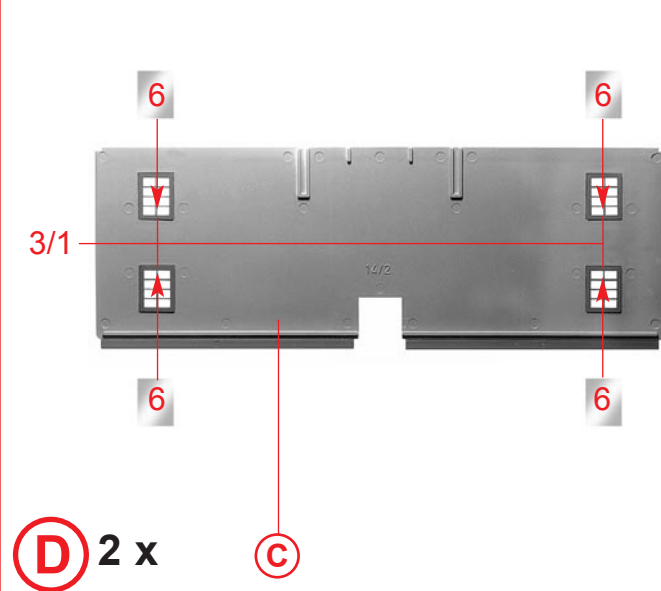
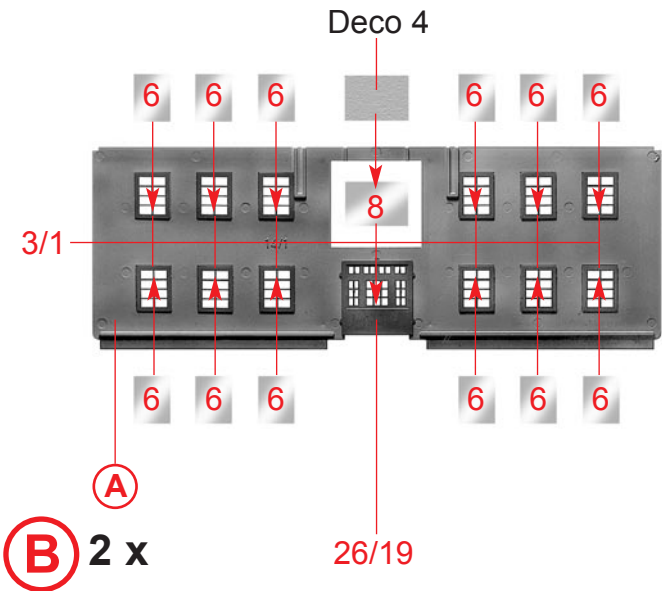
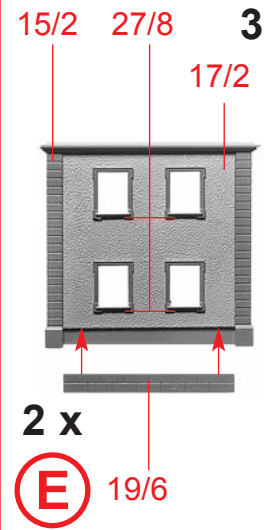
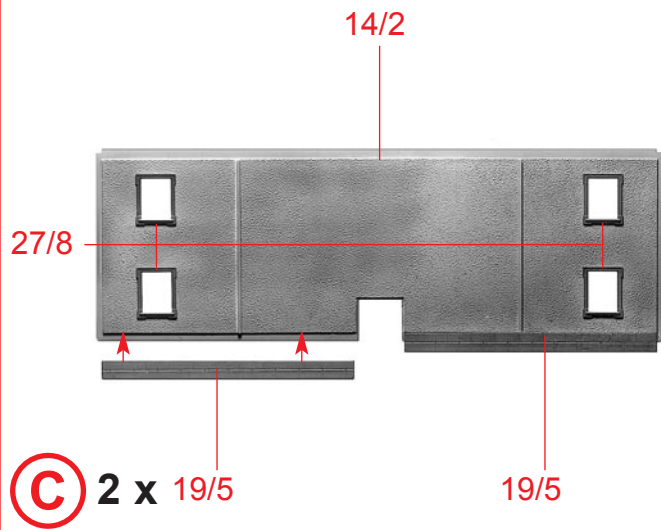
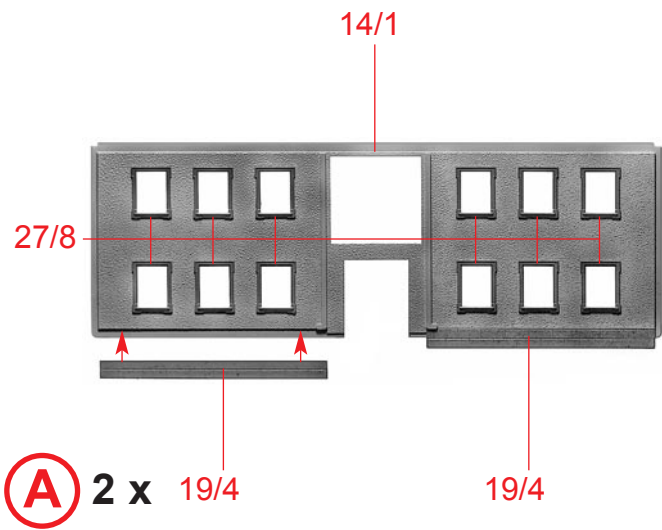

4

3/6

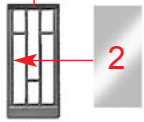

2

**L** 4 x

**M** 2 x

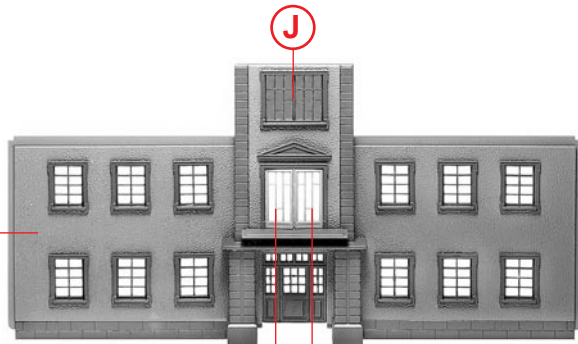

**L**

Variante:  
Deco 12

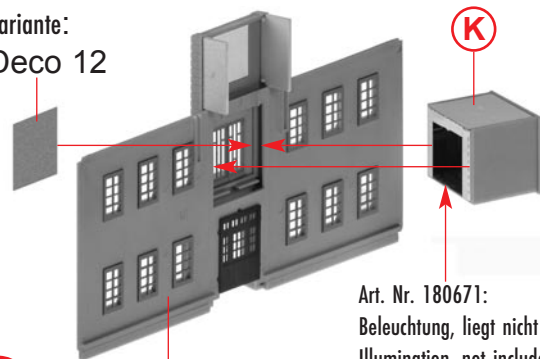

**N** 2 x **M**

Art. Nr. 180671:  
Beleuchtung, liegt nicht bei  
Illumination, not included  
Eclairage, non inclus  
Verlichting, niet inbegrepen

Papiermaske  
Papermask  
Masque papier  
Masker

**M2**

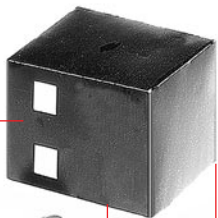

**N** Art. Nr. 180667:  
Beleuchtung, liegt nicht bei  
Illumination, not included  
Eclairage, non inclus  
Verlichting, niet inbegrepen

**F**

**H**

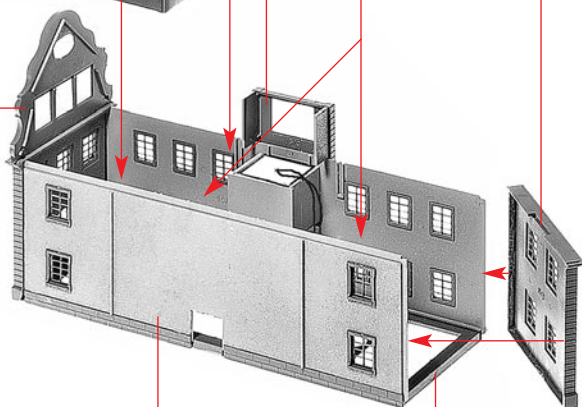

**O**

**D**

13/1

Papiermaske  
Papermask  
Masque papier  
Masker

**M1**

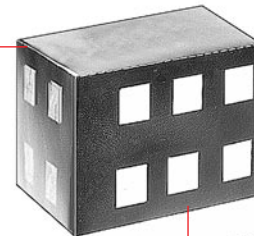

22/3 27/13 19/3



**O**

**P**

19/3

27/14

13/4

27/14

19/8

19/2

19/7



**Q**

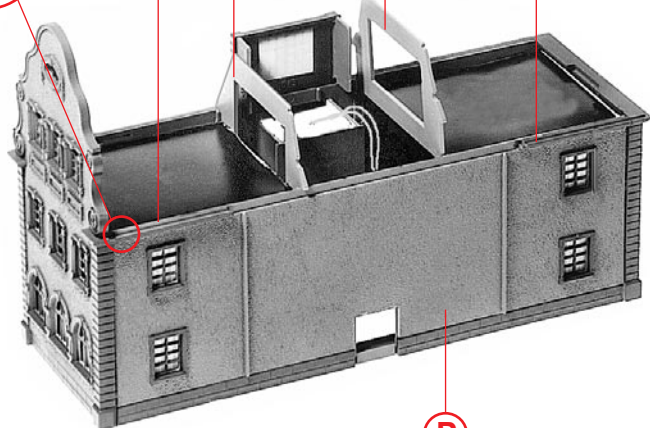

**P**

26/7

26/5

21/1

26/6

**R**

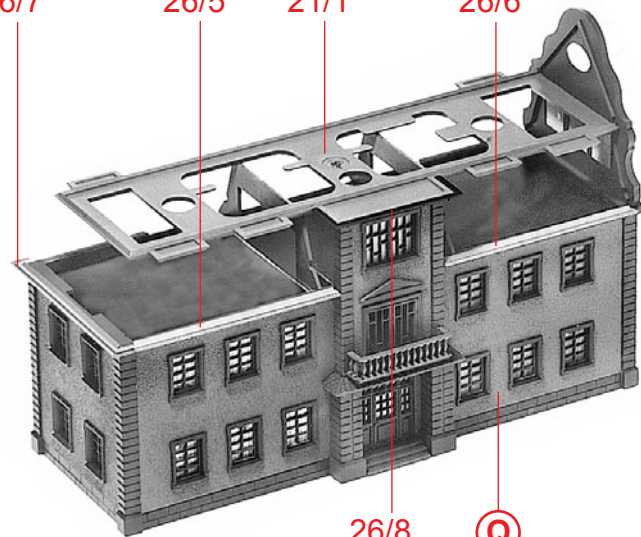

26/8

**Q**

26/2

26/4

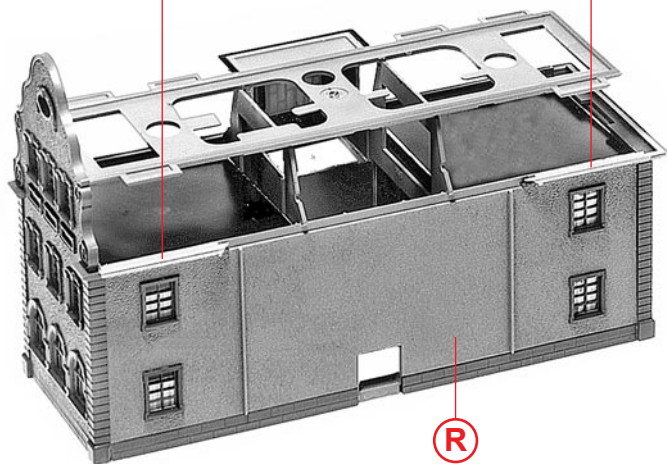

**R**

**T** 9 x

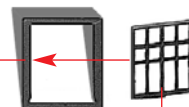

3/4

**T** 9 x

**U** 9 x

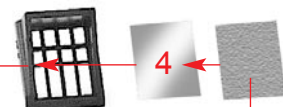

4

Deco 2

2/6

2/7



**V** 9 x **U**

**T**

**U** 9 x

**W**

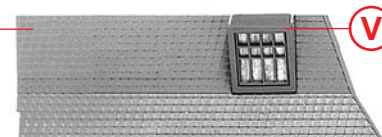

**V**



31/3

**X**

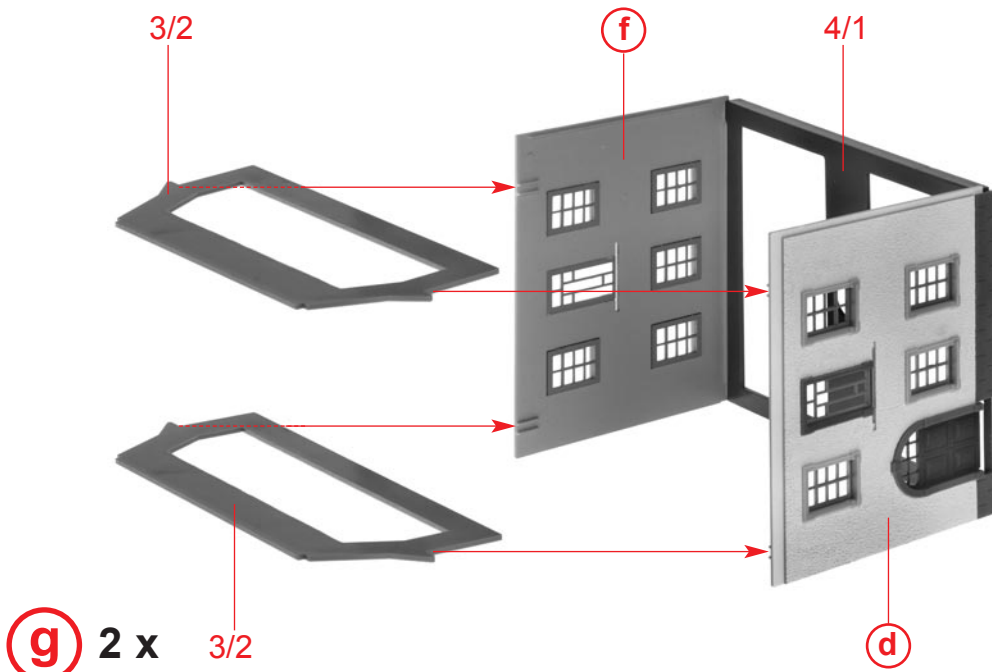
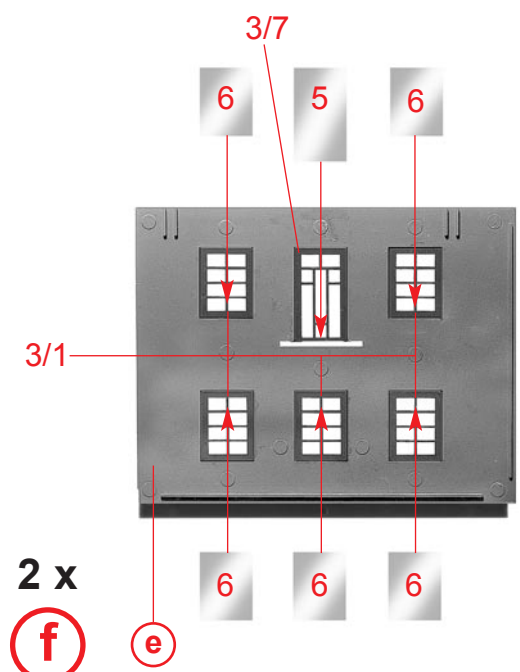
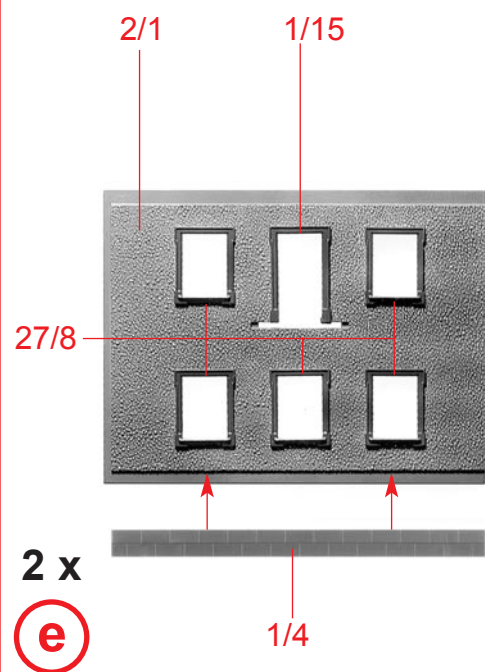
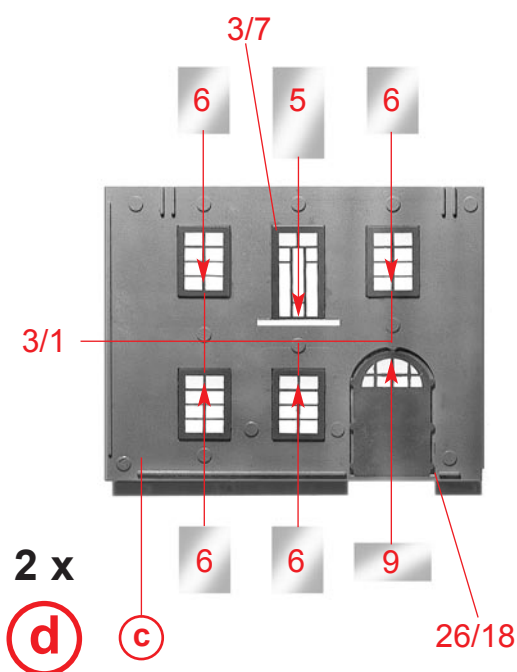
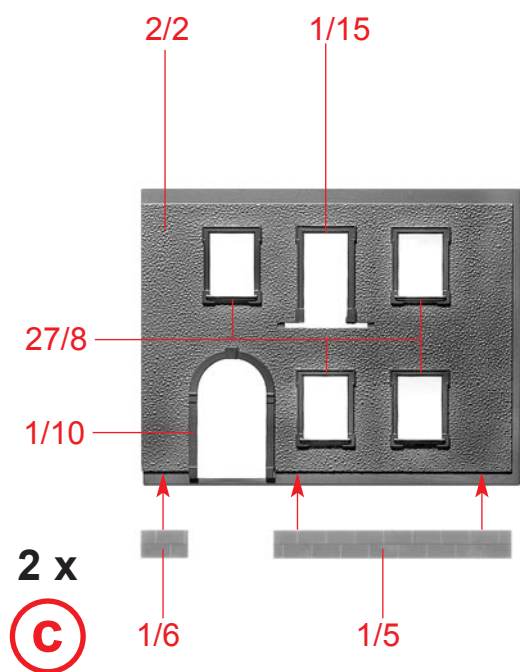
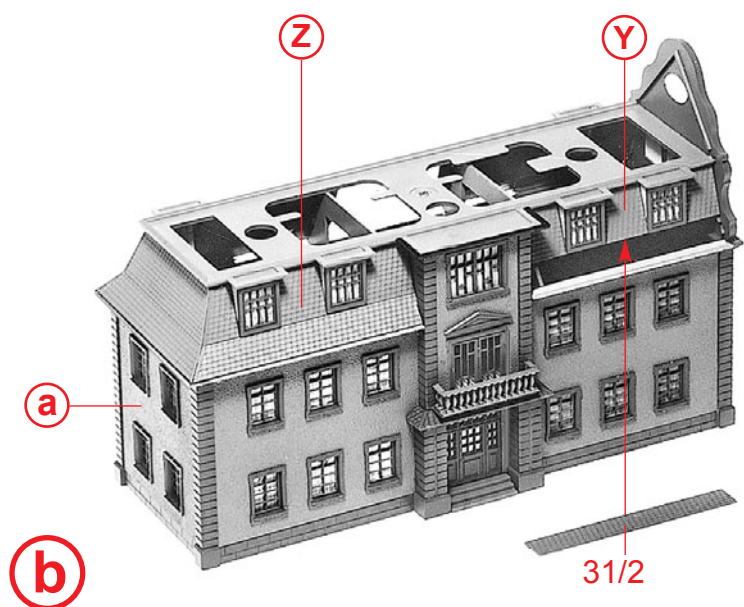
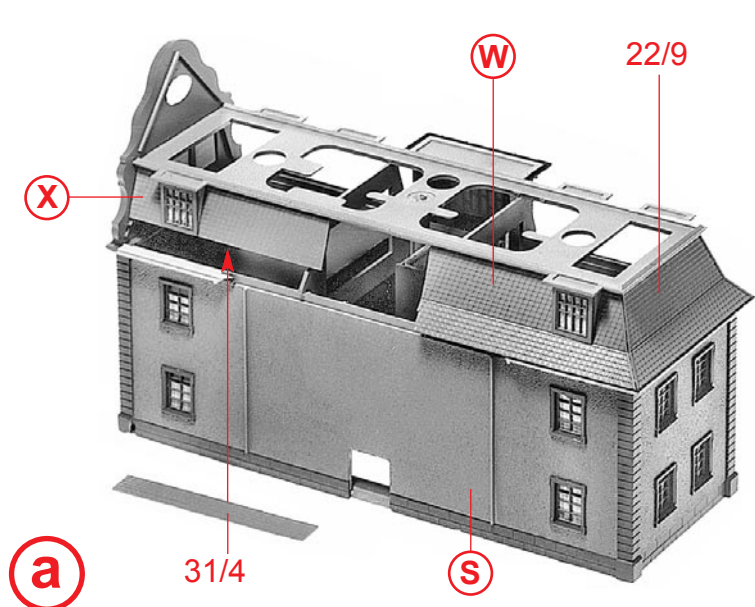
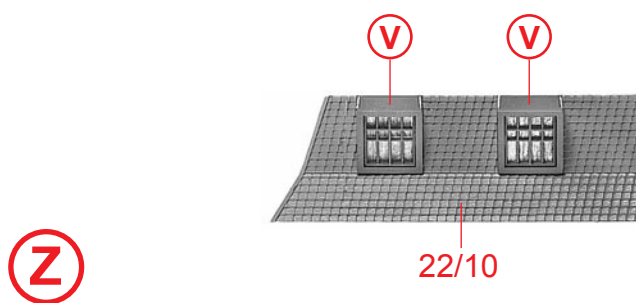
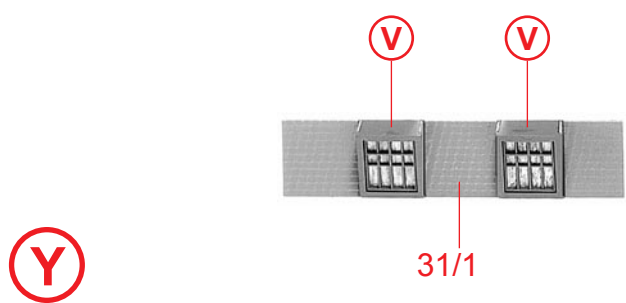

6



**h** 2 x

1/8



**i** 2 x

1/9

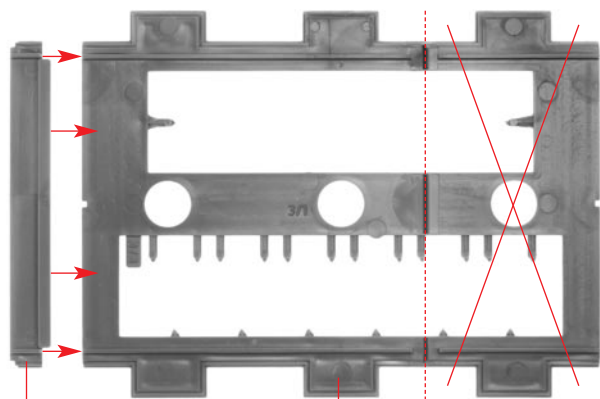

**j** 2 x 3/5

3/1

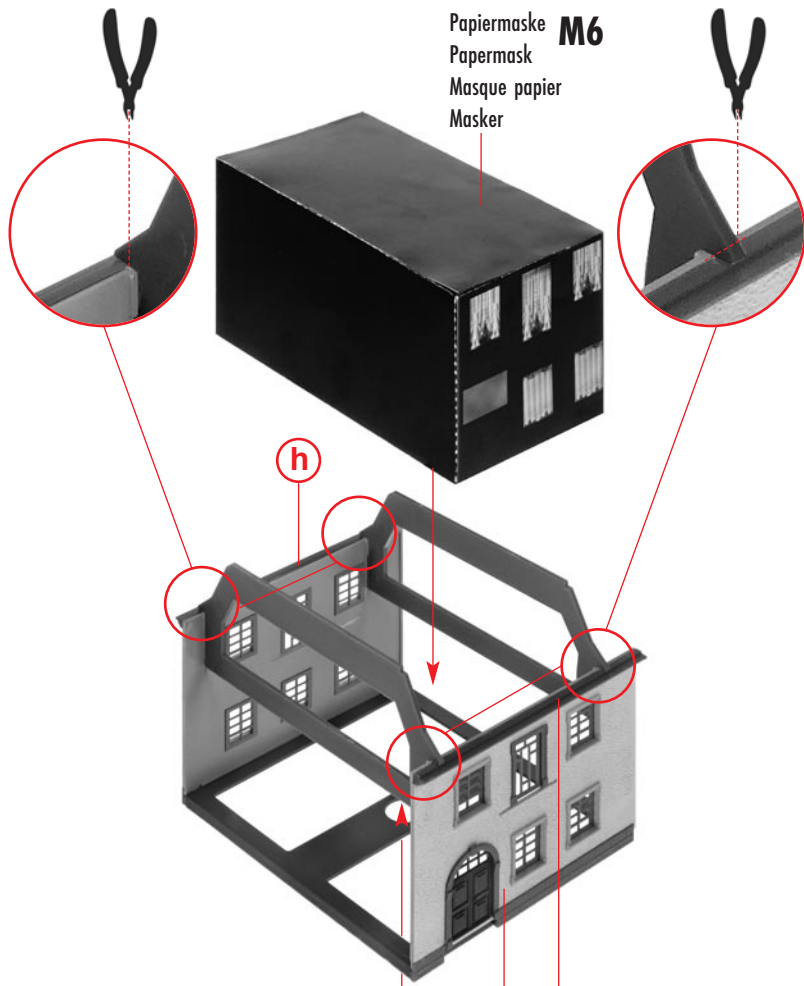

**k** 2 x

Art. Nr. 180667:  
 Beleuchtung, liegt nicht bei  
 Illumination, not included  
 Eclairage, non inclus  
 Verlichting, niet inbegrepen

**g** **i**

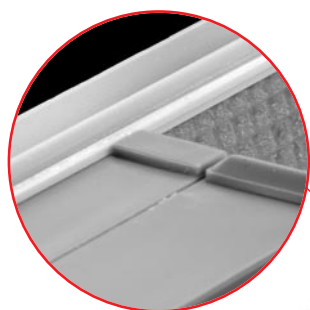

26/3

**j**

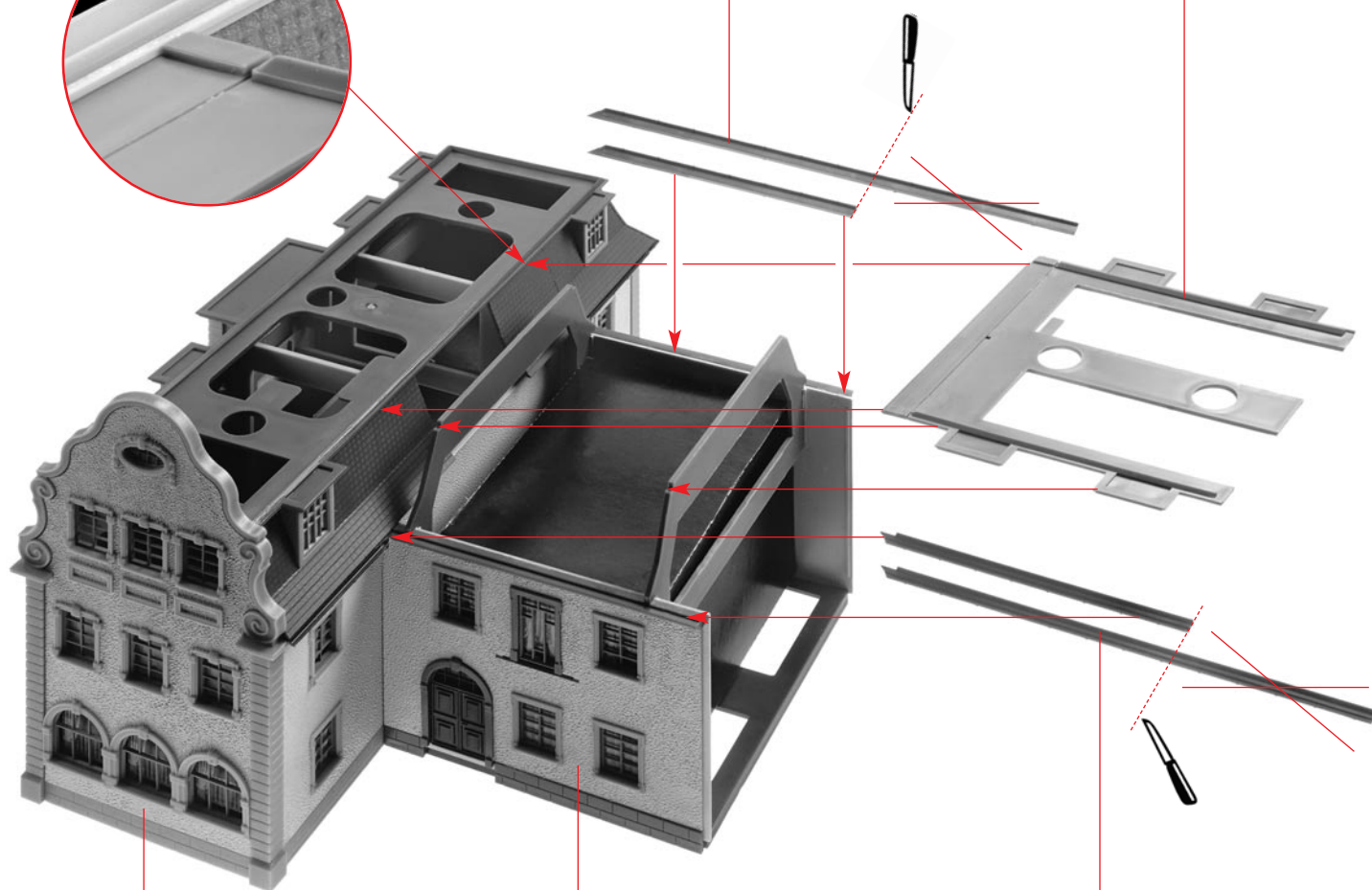

**l**

**b**

**k**

26/1

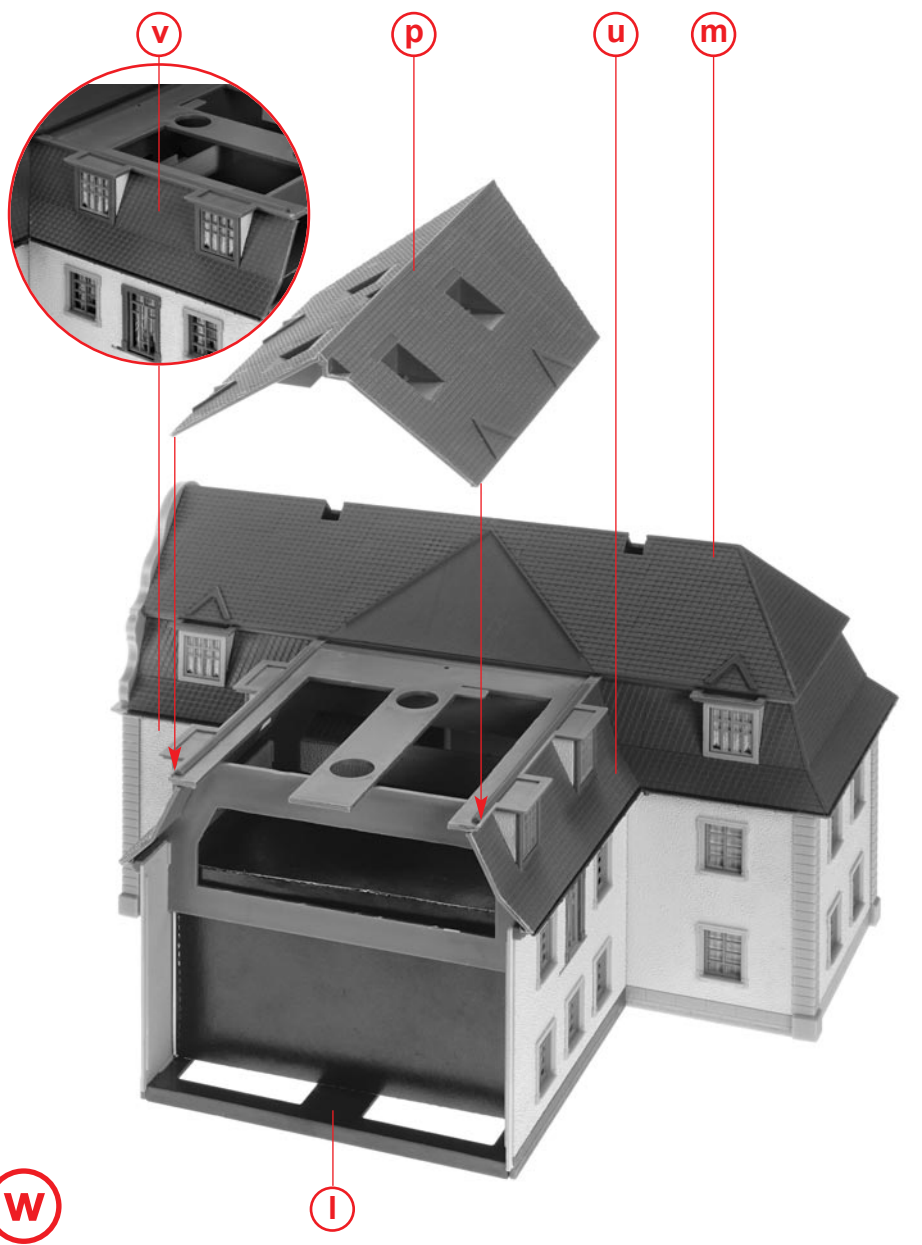
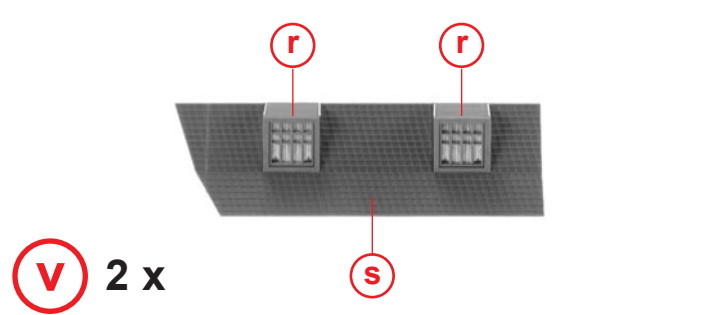
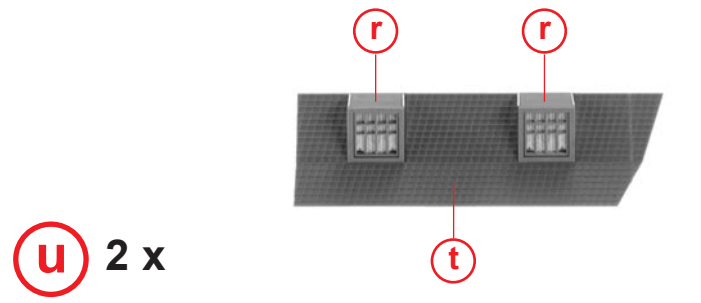
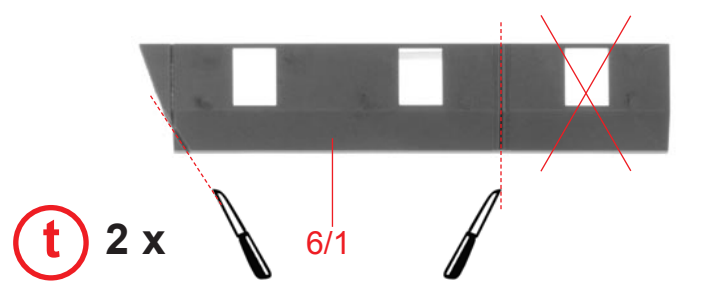
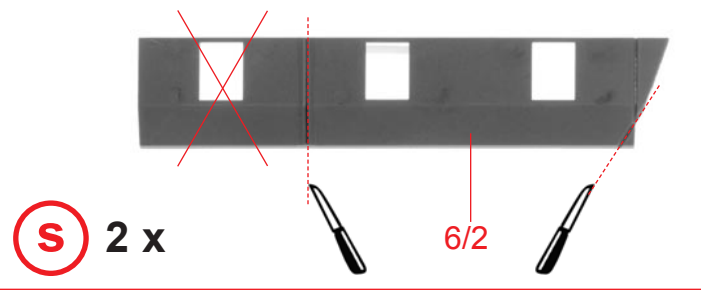
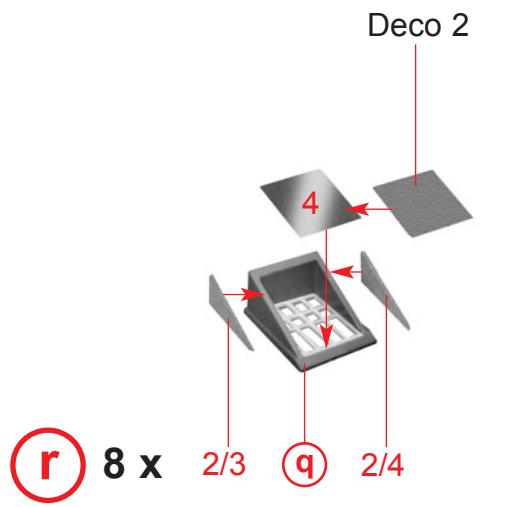
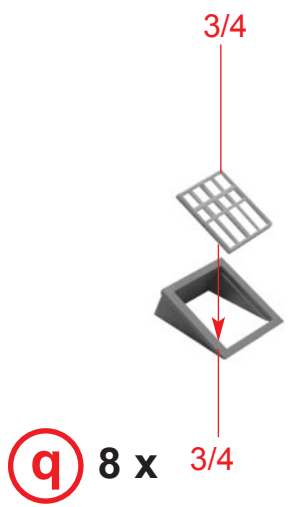
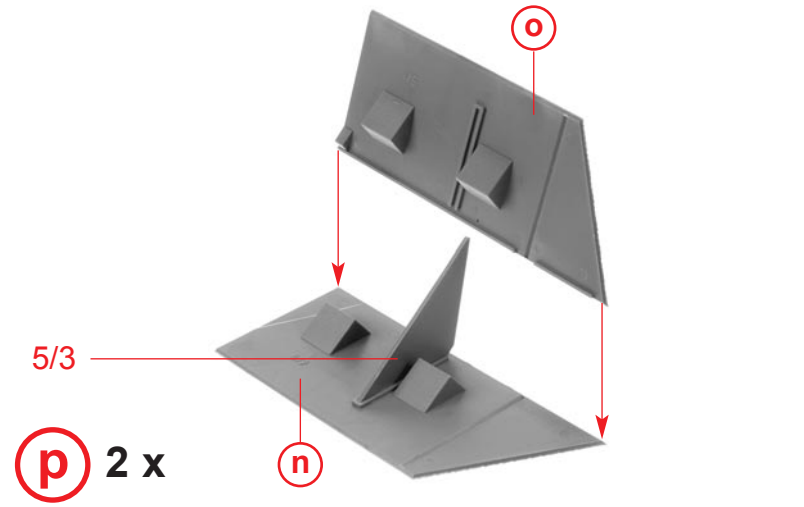
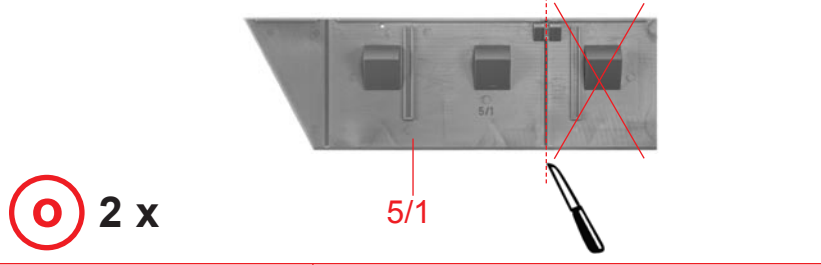
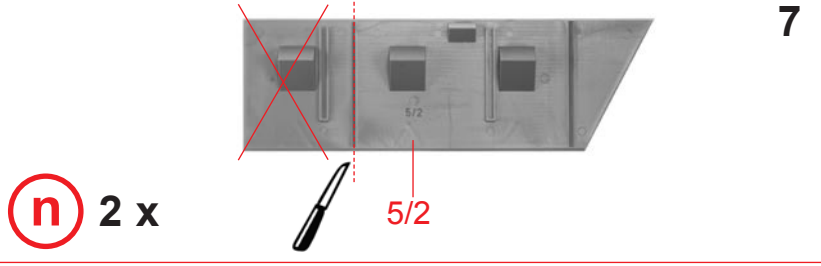
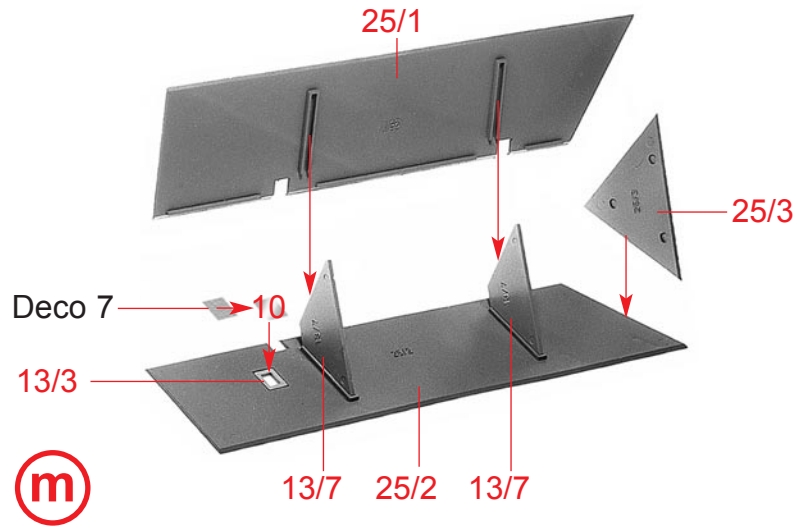

8

**F** Art. Nr. 180667:  
Beleuchtung, liegt nicht bei  
Illumination, not included  
Eclairage, non inclus  
Verlichting, niet inbegrepen

**N** Papiermaske  
Papermask  
Masque papier  
Masker  
**M5**

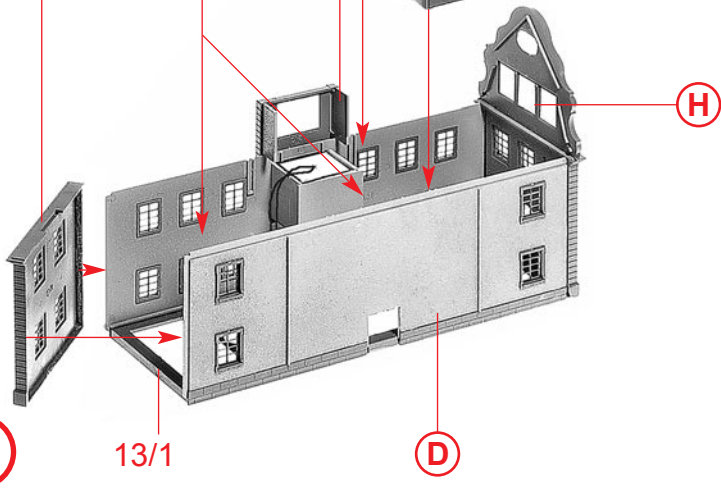

**M4** Papiermaske  
Papermask  
Masque papier  
Masker

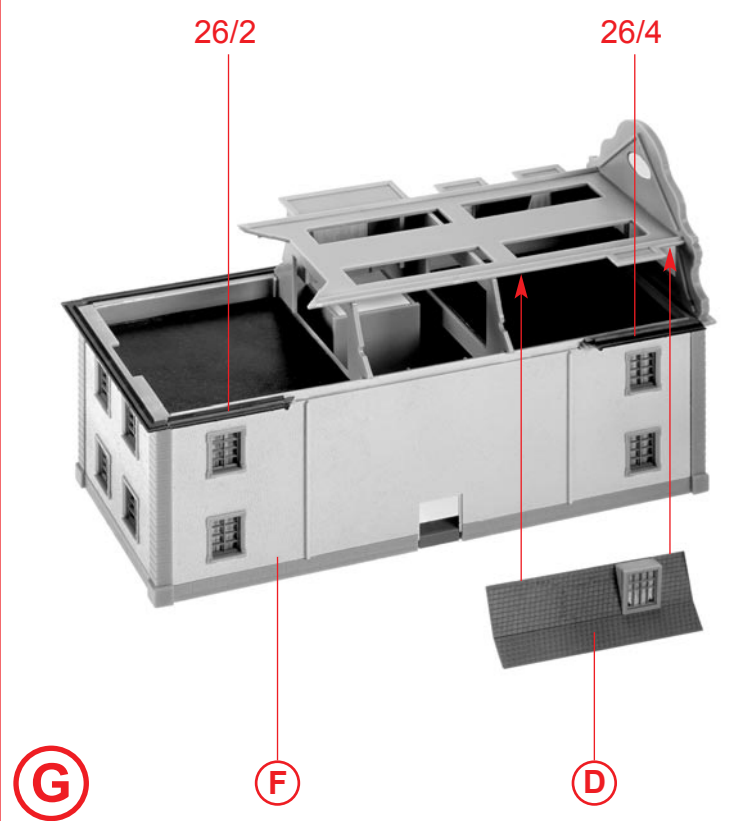
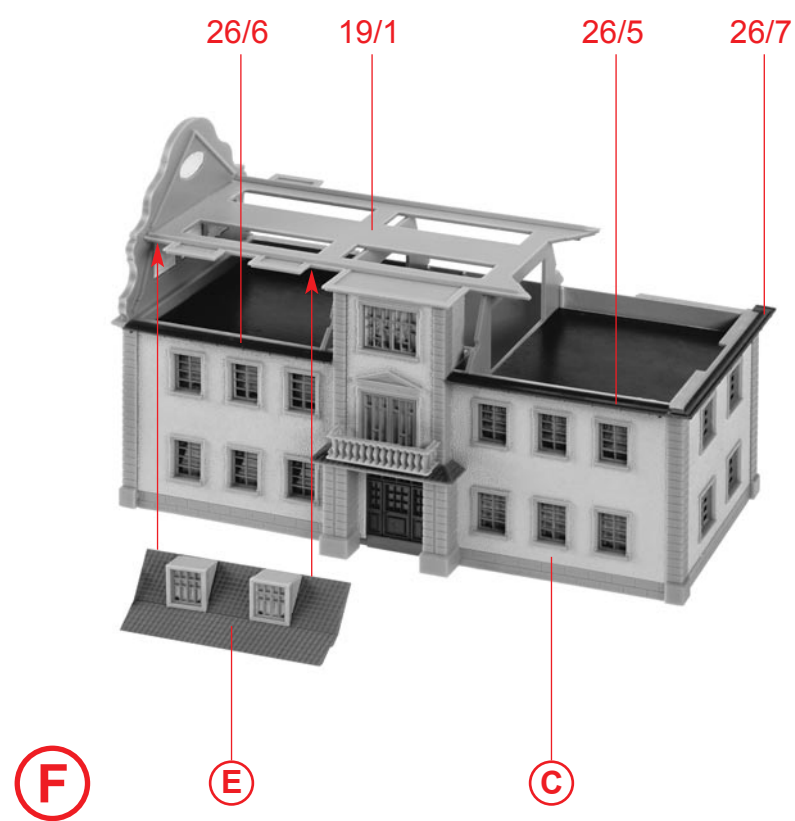
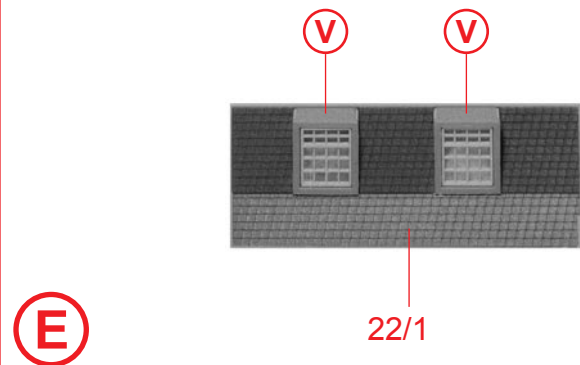
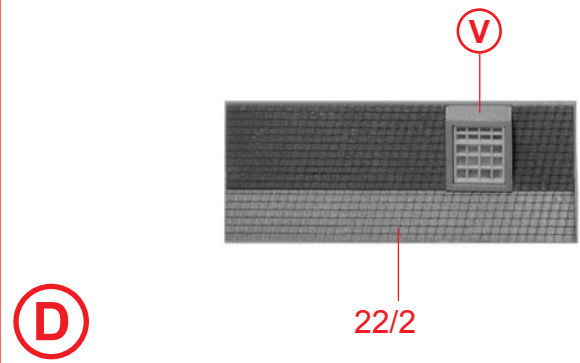
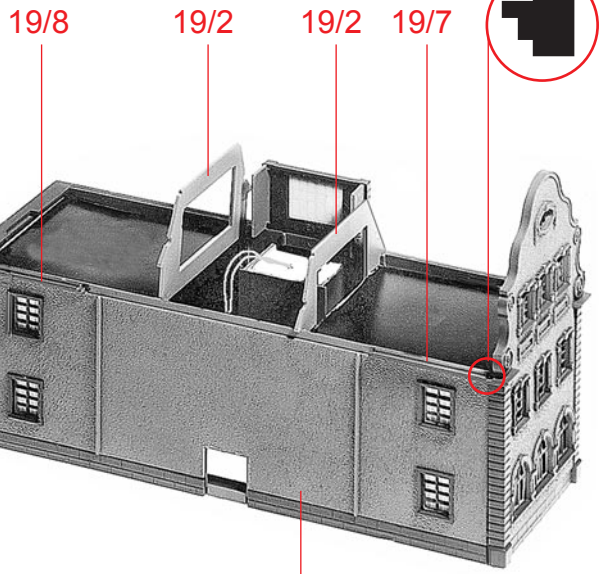
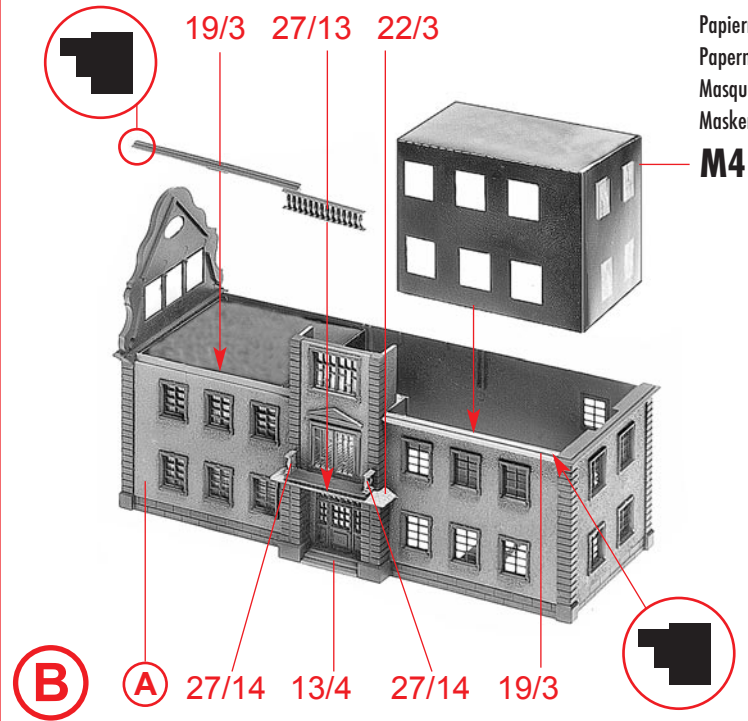

Fensterfolie: Die beiliegende Fensterfolie entsprechend der benötigten Größe ausschneiden und vorsichtig mit wenig Klebstoff auf die Rückseite der Fensterrahmen aufkleben.

Window foil: Cut the attached window foil according the illustrations and glue it carefully with a little glue to the rear side of the window frames.

Feuille transparente pour fenêtres : Découper le feuillet transparent pour fenêtres inclus d'après l'illustration. Coller proprement avec un peu de colle sur la face arrière du cadre des fenêtres.

Vensterfolie: De meegeleverde vensterfolie conform de afbeeldingen uitknippen of uitsnijden en voorzichtig met een beetje lijm op de achterzijde van het raam plakken.

**H** 23/2  
gelb yellow jaune geel

**I** 3 x 28/1 20/1  
gelb yellow jaune geel 2 x 23/1 + **H**

grau grey gris grijs 23/7  
**J** 3 x **I**  
Fensterfolie Window foil Feuille transparente Vensterfolie

20/2  
**K** 4 x 23/3  
gelb yellow jaune geel

**L** **K** **J**

20/1  
**M** 23/2  
gelb yellow jaune geel

**N** **L** **J** **K** **M** **K**  
23/6 23/6 **J**

28/3 23/4 gelb yellow jaune geel  
**O** 4 x 28/2 20/7

grau grey gris grijs 23/8 Fensterfolie Window foil Feuille trans. Vensterfolie  
**P** 4 x 23/9 **O**

Art. Nr. 180667: Beleuchtung, liegt nicht bei Illumination, not included Eclairage, non inclus Verlichting, niet inbegrepen  
Papiermaske M9 Papermask Masque papier Masker  
**S** **P** **R** **P** **R** **P**

28/3 23/5 gelb yellow jaune geel  
**Q** 4 x 20/8

grau grey gris grijs 23/8 Fensterfolie Window foil Feuille trans. Vensterfolie  
**R** 4 x **Q**

**S** **R** **P** 24/4 **R**

10

Papiermaske **M3**  
Papermask  
Masque papier  
Masker

Art. Nr. 180667:  
Beleuchtung, liegt nicht bei  
Illumination, not included  
Eclairage, non inclus  
Verlichting, niet inbegrepen

(N)

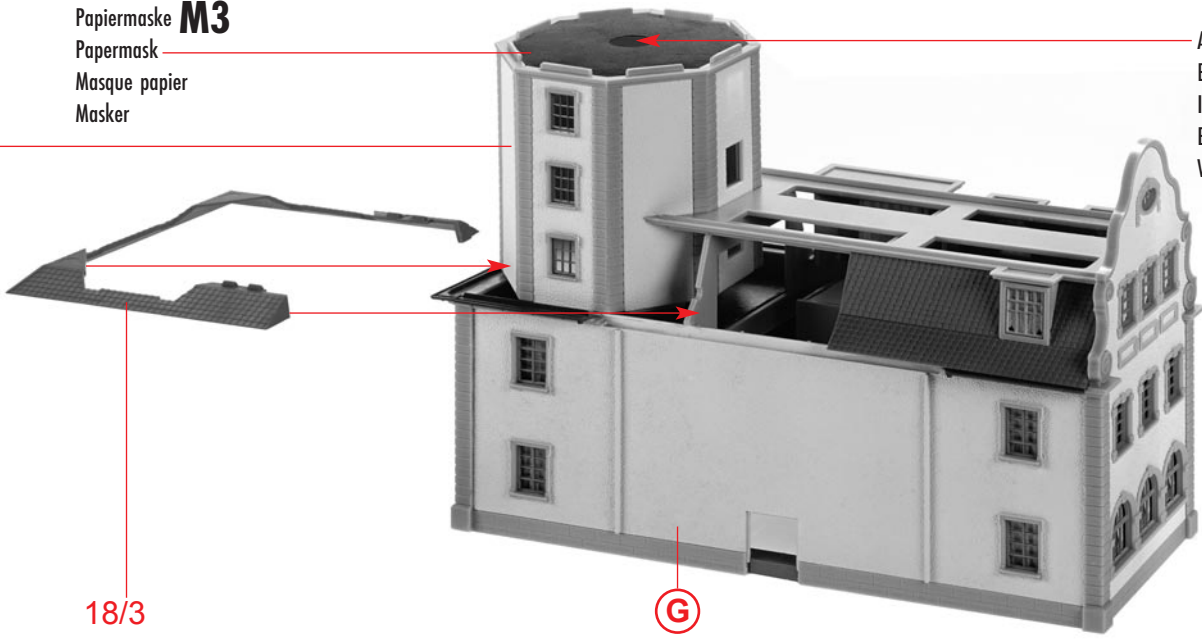

(T)

18/3

(G)

18/6

(S)

18/5

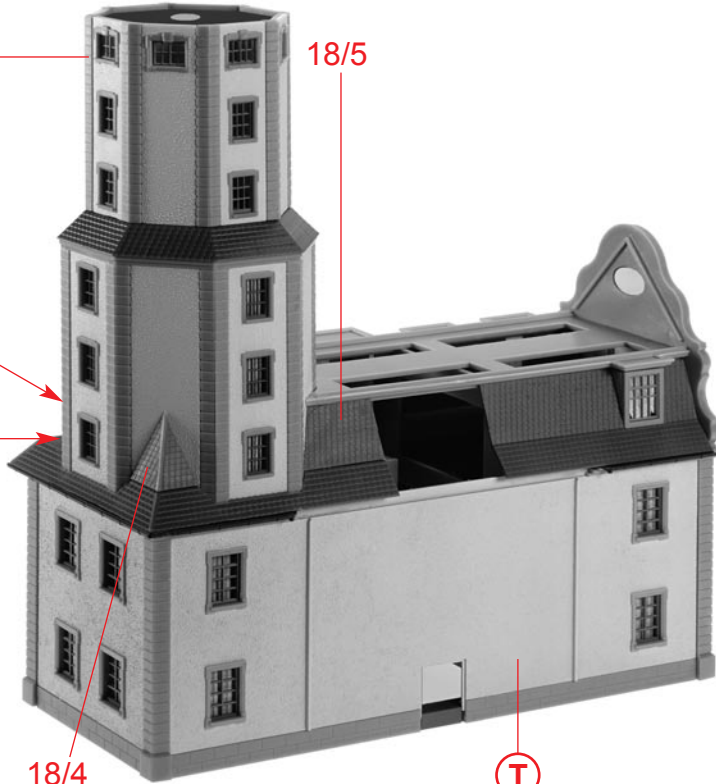

(U)

18/4

18/4

(T)

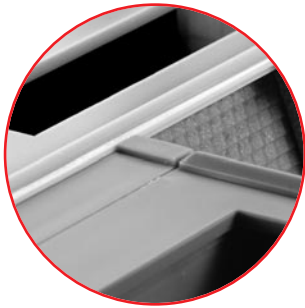

26/3

(j)

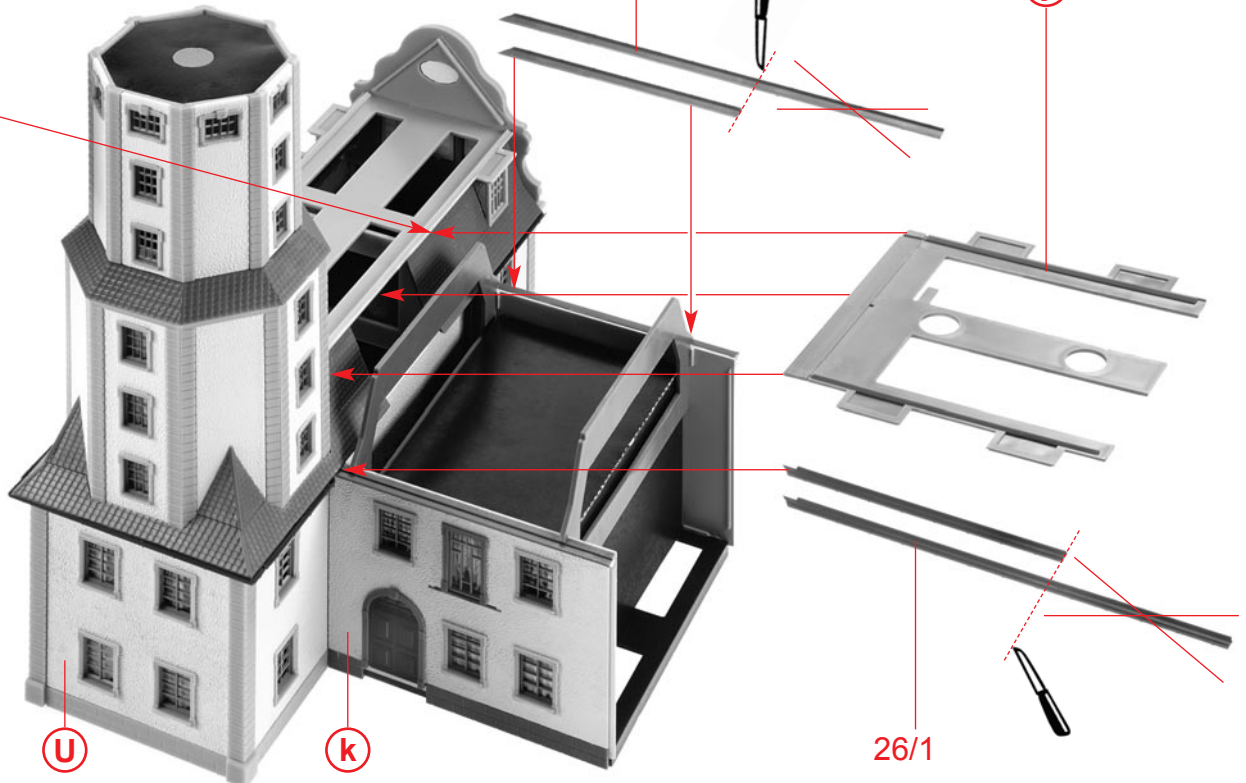

(V)

(U)

(k)

26/1

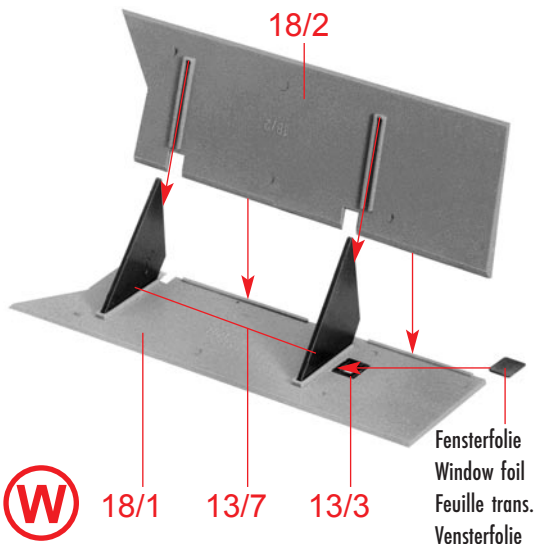

**W**

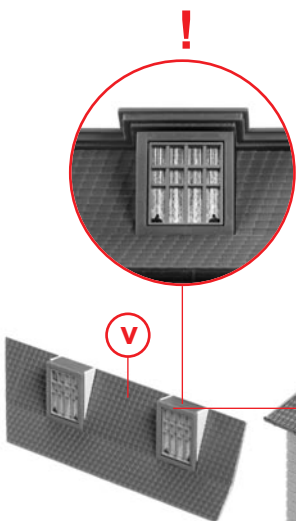

**Y**

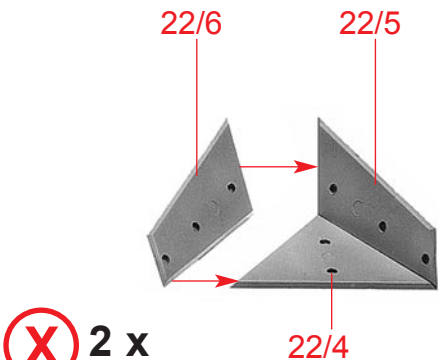
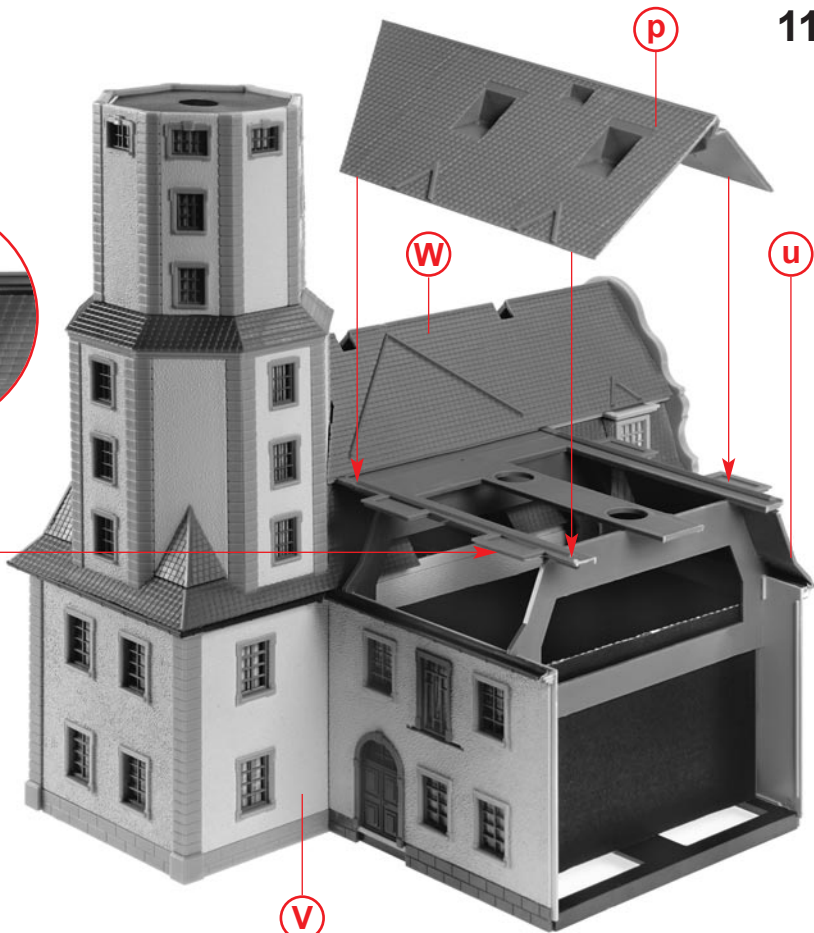

**X** 2 x

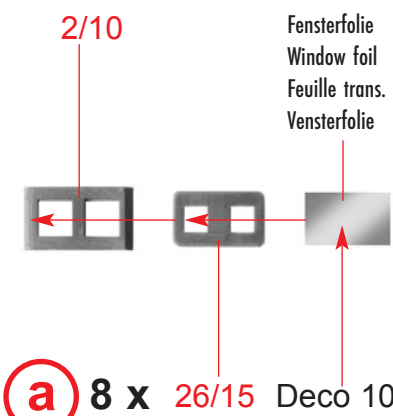

**a** 8 x

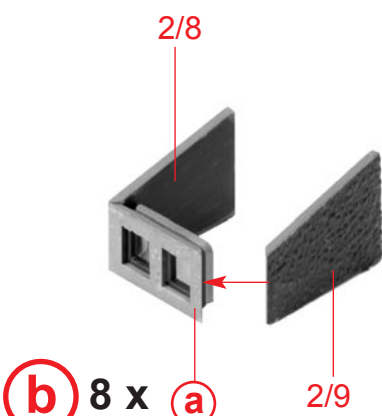

**b** 8 x **a**

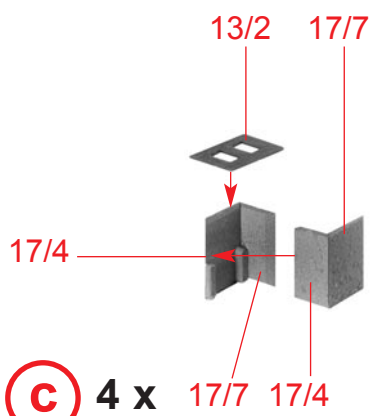

**c** 4 x 17/7 17/4

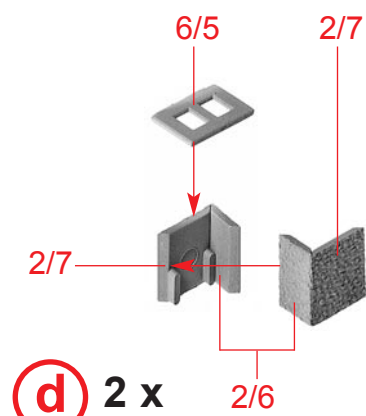

**d** 2 x

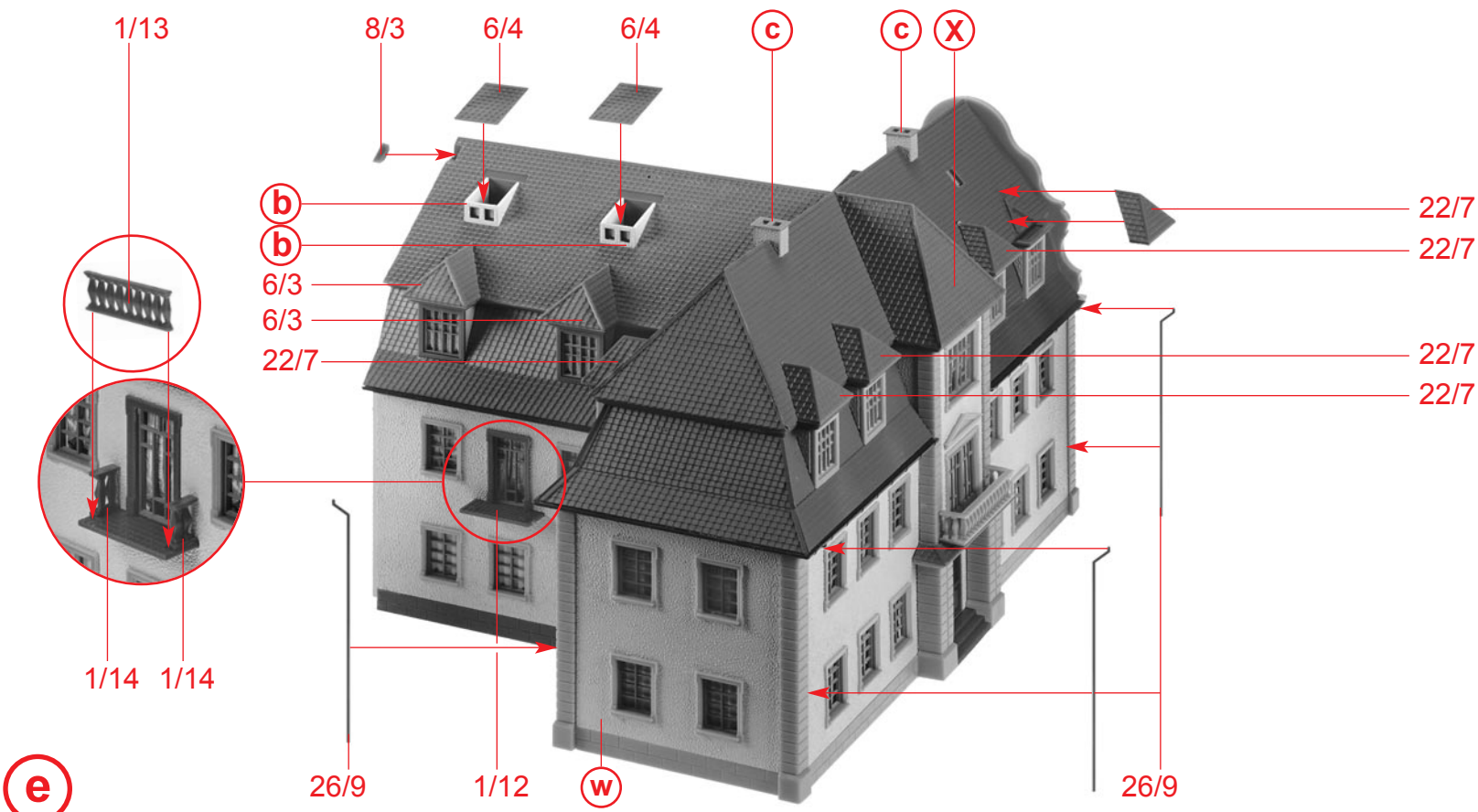

12

1/13

6/4

(d) 6/4

8/1

(b)

(b)

22/7

6/3

(e)

1/16

1/12

(f)

1/14

1/14

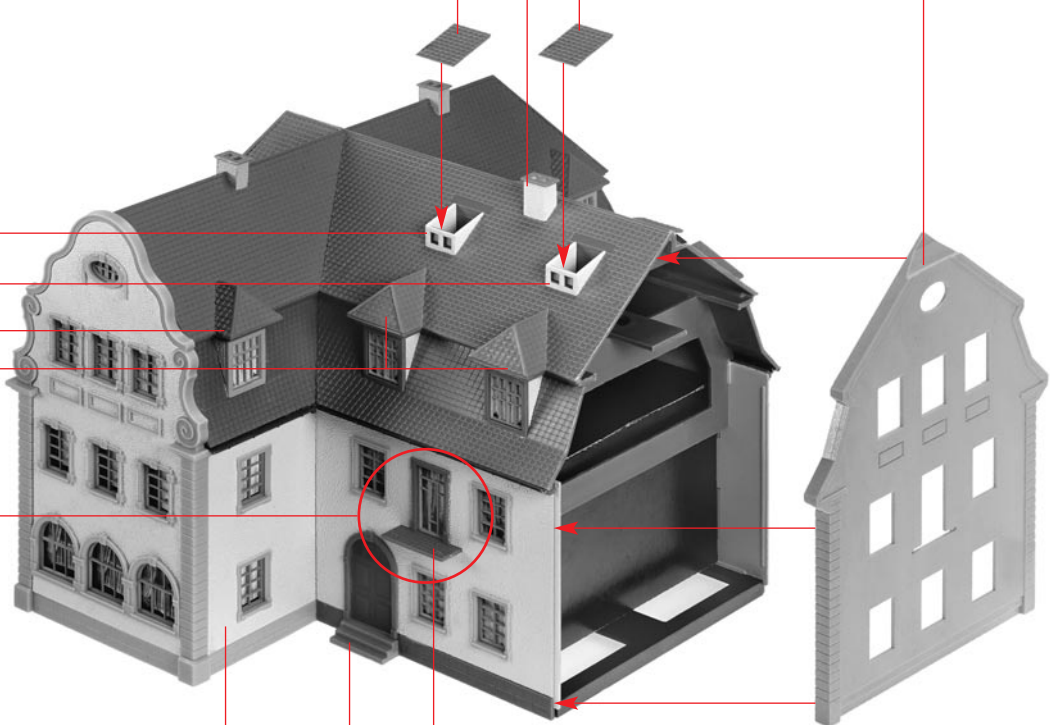
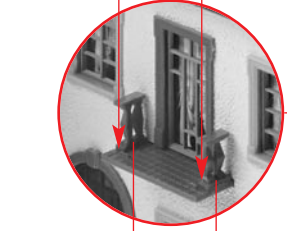
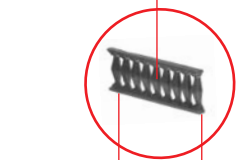

1/13

8/3

6/4

6/4

(c)

(c)

20/4

20/4

(b)

(b)

6/3

6/3

(x)

22/7

22/7

1/14

1/14

(g)

26/9

1/12

(y)

26/9

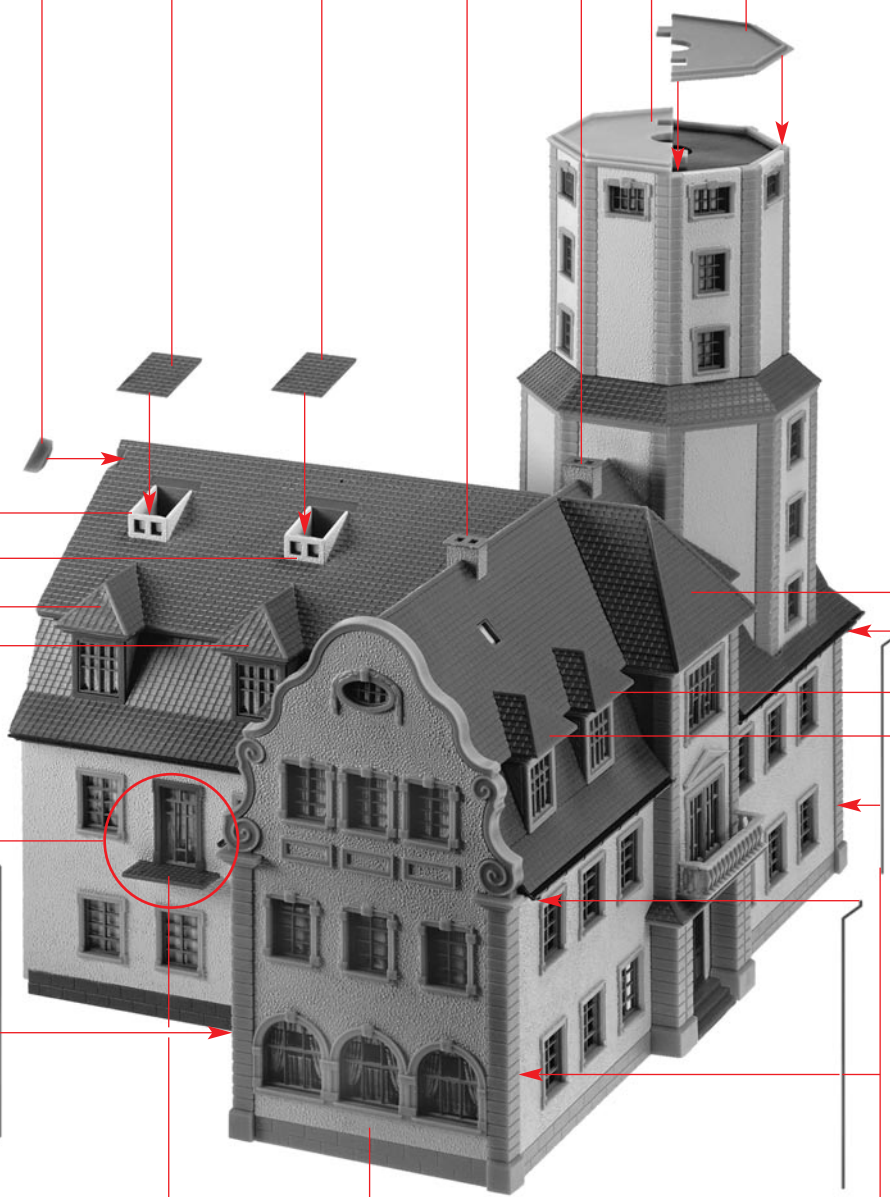
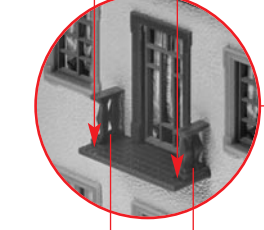
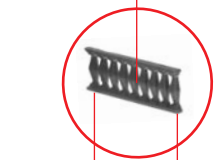

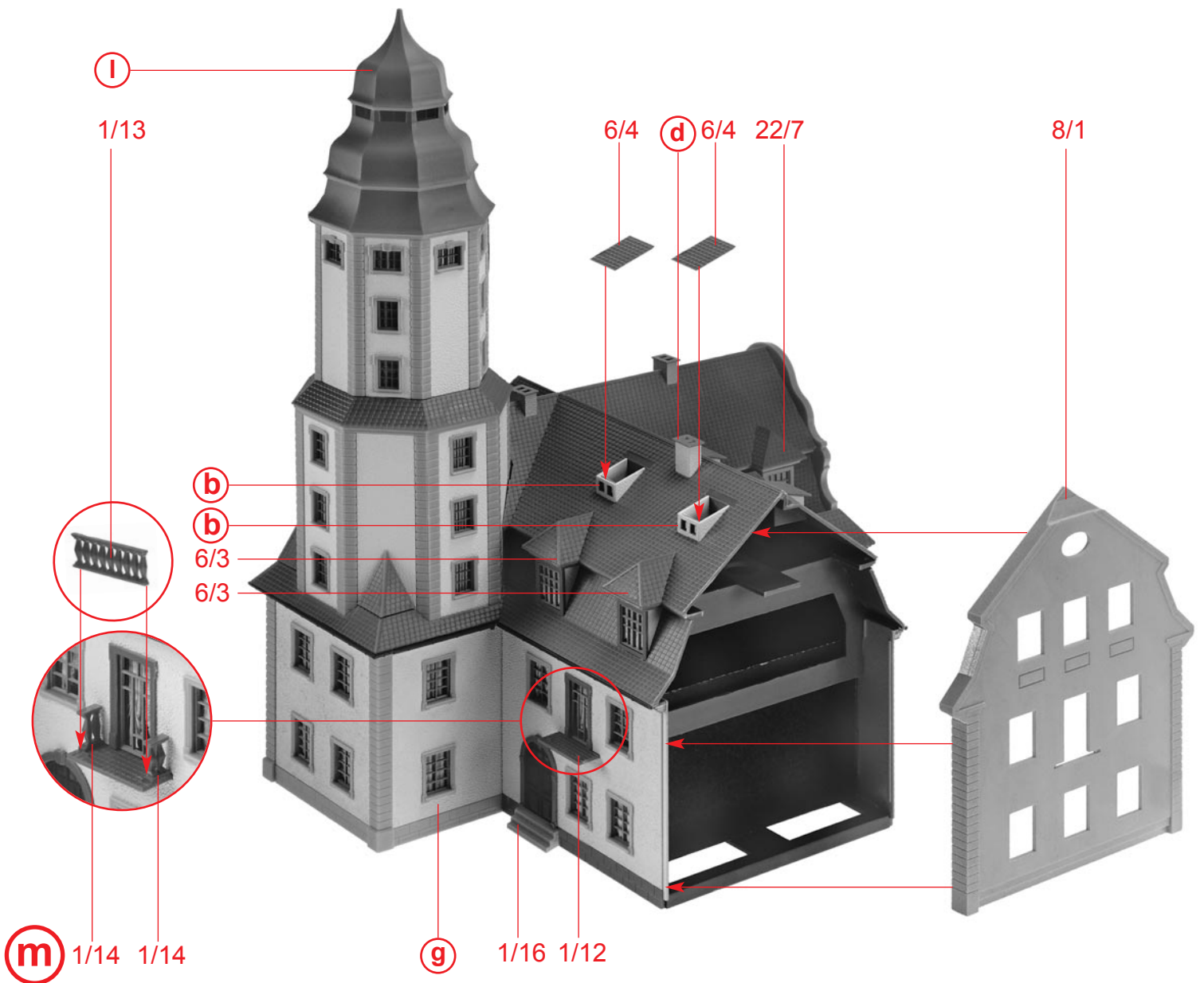
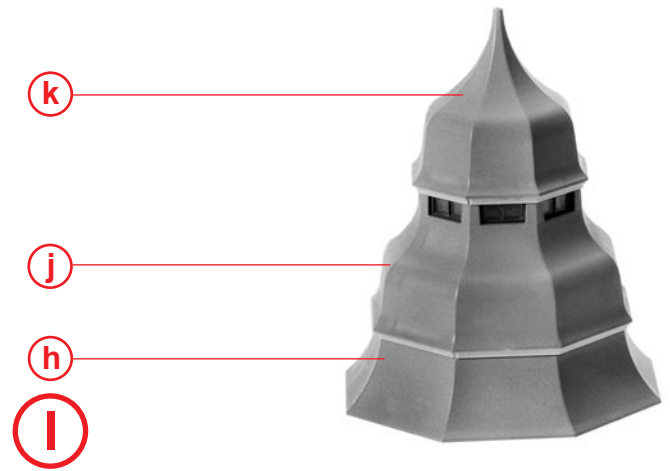
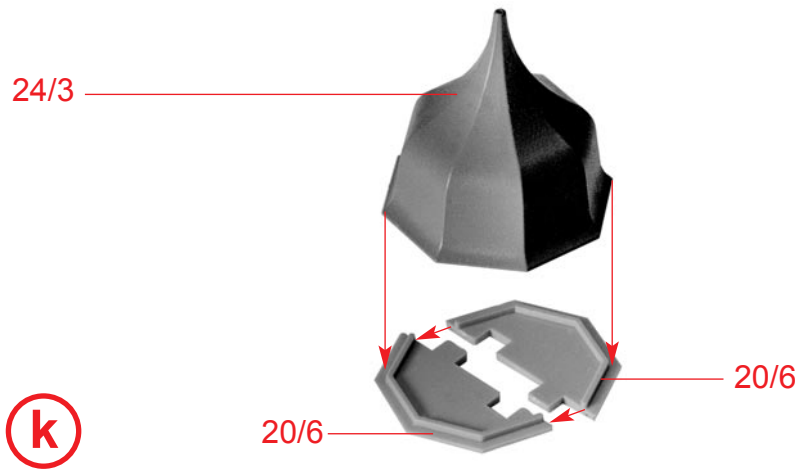
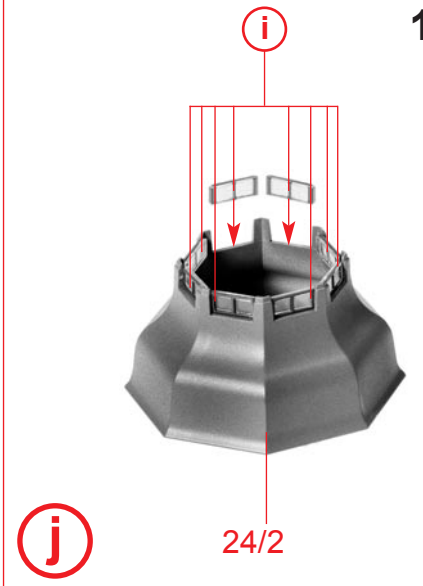
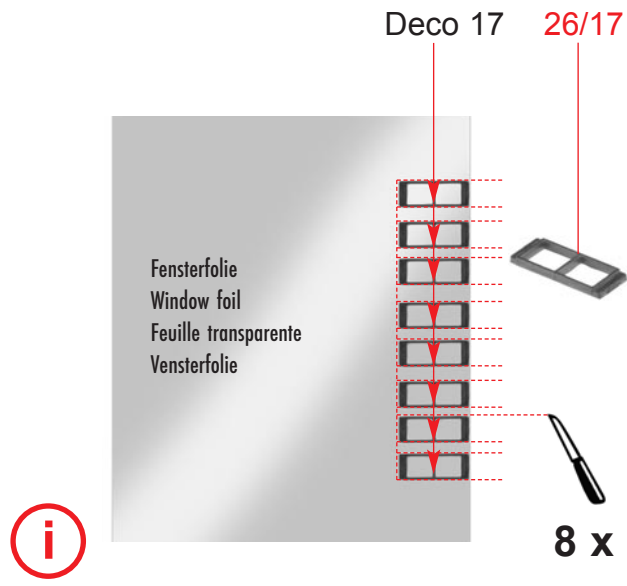
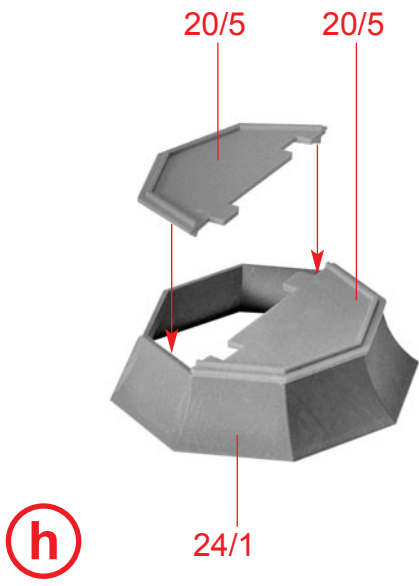

**14** Lasercut-Kleber verwenden.  
Use Lasercut glue.  
Utilisez la colle Lasercut.  
Gebruik Lasercutlijm.

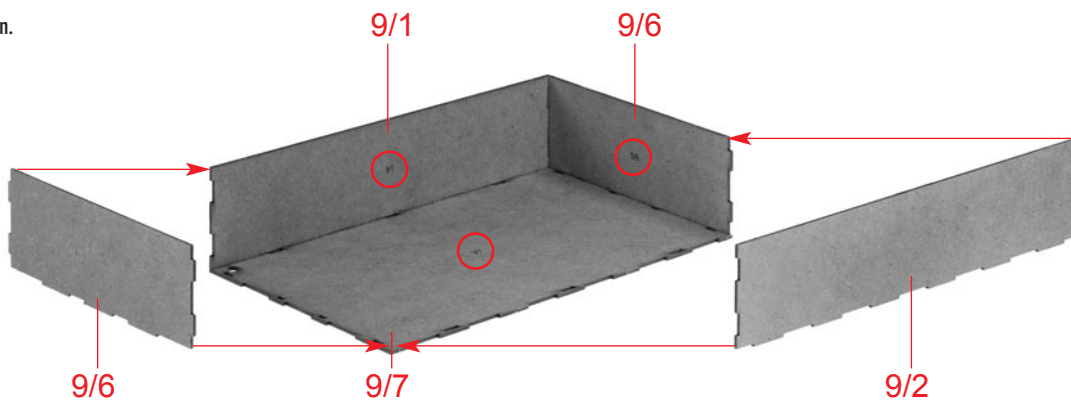

**A**

Lasercut-Kleber verwenden.  
Use Lasercut glue.  
Utilisez la colle Lasercut.  
Gebruik Lasercutlijm.

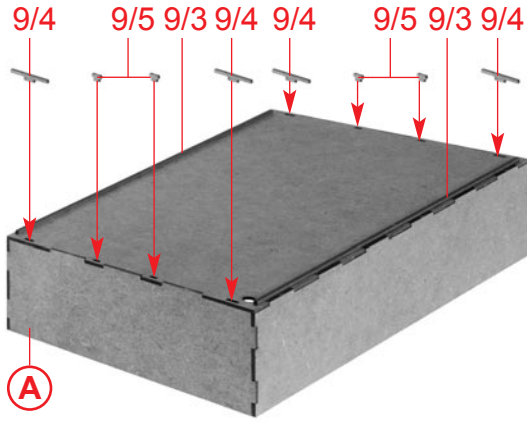

**B**

**A**

Lasercut-Kleber verwenden.  
Use Lasercut glue.  
Utilisez la colle Lasercut.  
Gebruik Lasercutlijm.

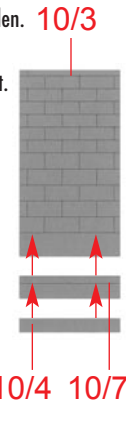

**C** 2 x 10/4 10/7

Lasercut-Kleber verwenden.  
Use Lasercut glue.  
Utilisez la colle Lasercut.  
Gebruik Lasercutlijm.

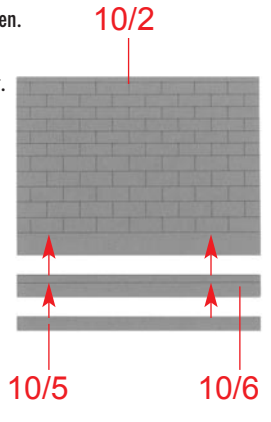

**D** 2 x 10/5 10/6

Lasercut-Kleber verwenden.  
Use Lasercut glue.  
Utilisez la colle Lasercut.  
Gebruik Lasercutlijm.

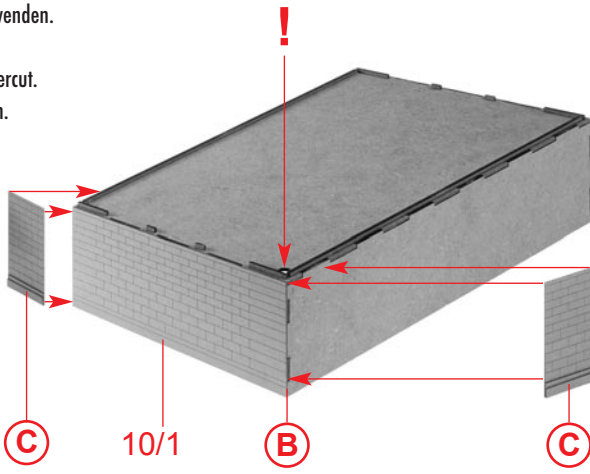

**E**

**C**

10/1

**B**

**C**

Lasercut-Kleber verwenden.  
Use Lasercut glue.  
Utilisez la colle Lasercut.  
Gebruik Lasercutlijm.

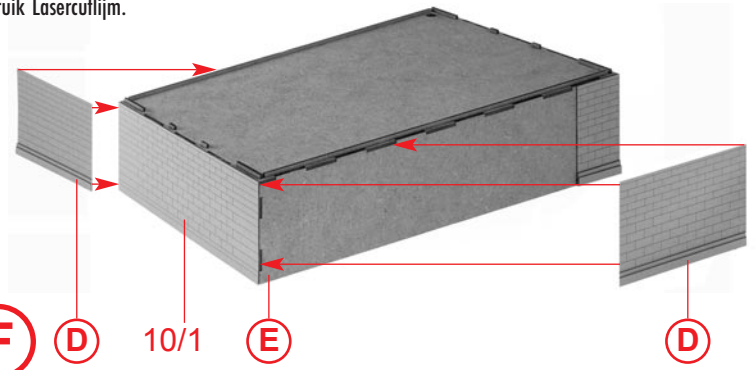

**F**

**D**

10/1

**E**

**D**

15 mm →

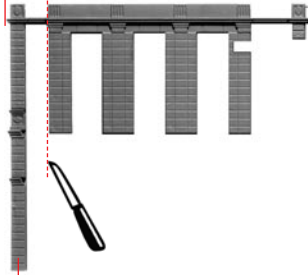

**G**

24/3

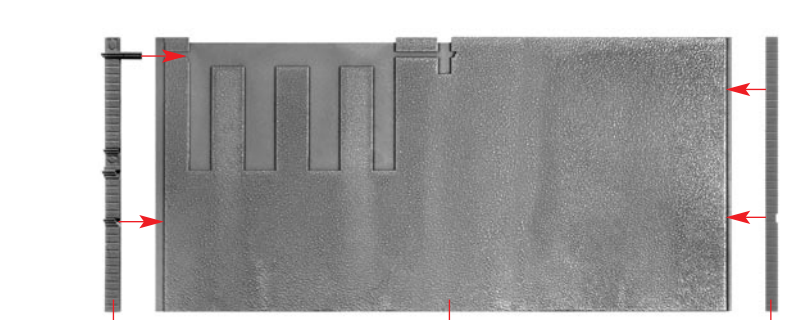

**H**

**G**

18/2

22/5

24/1

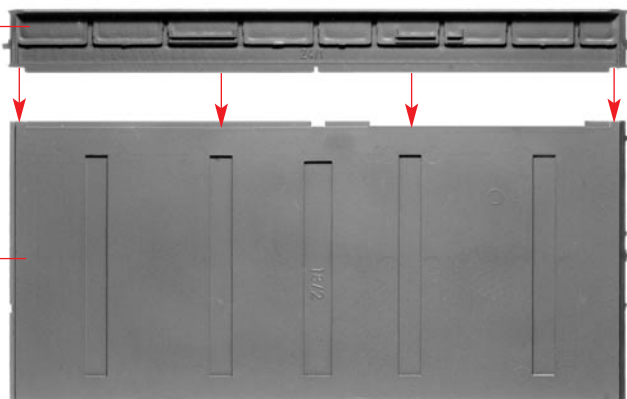

**H**

**I**

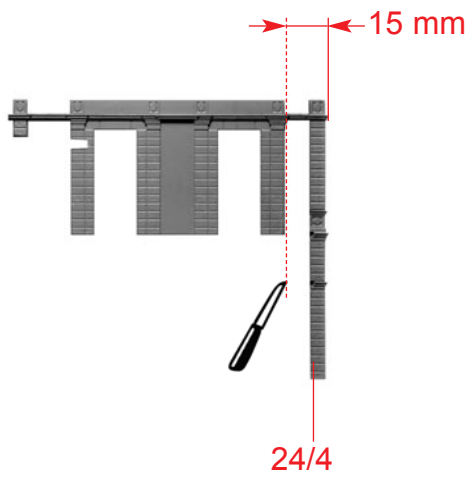

**J**

**K**

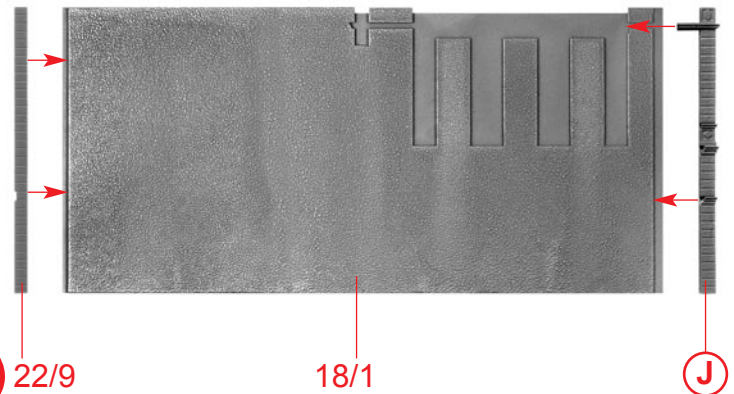

20/11

24/2

**K**

**L**

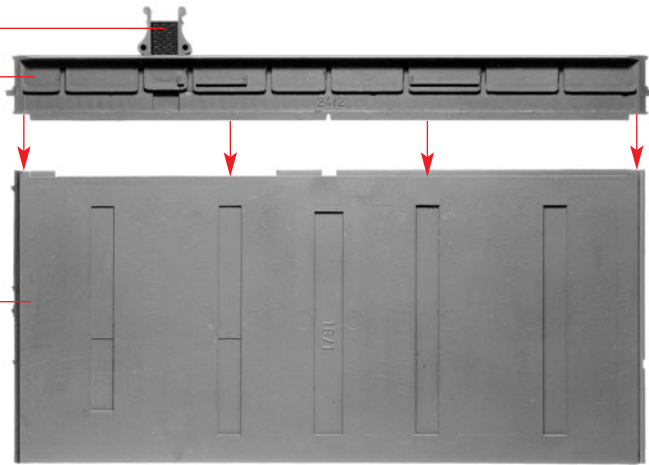

22/1

22/6

20/2

nicht kleben  
do not glue  
ne pas coller  
niet lijmen

nicht kleben  
do not glue  
ne pas coller  
niet lijmen

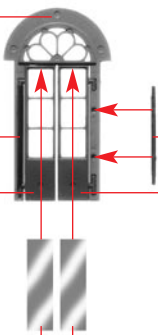

Fensterfolie  
Window foil  
Feuille transparente  
Vensterfolie

**M** 3 x

19/8

22/7

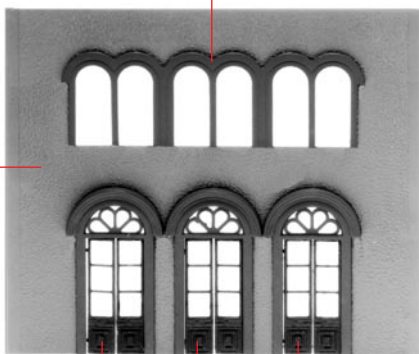

**N**

**M**

**M**

**M**

21/2

Deco 15

Fensterfolie  
Window foil  
Feuille transparente  
Vensterfolie

11/1

**N**

**O**

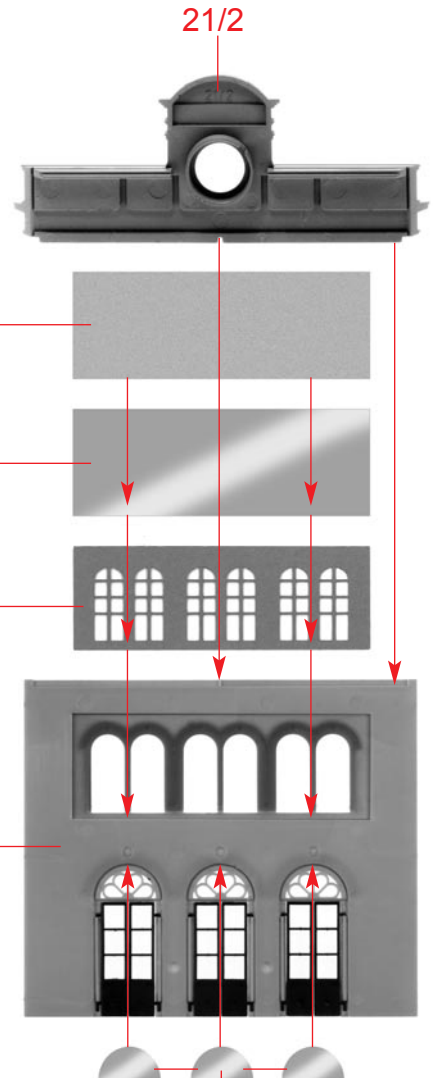

Fensterfolie  
Window foil  
Feuille transparente  
Vensterfolie

16

21/1

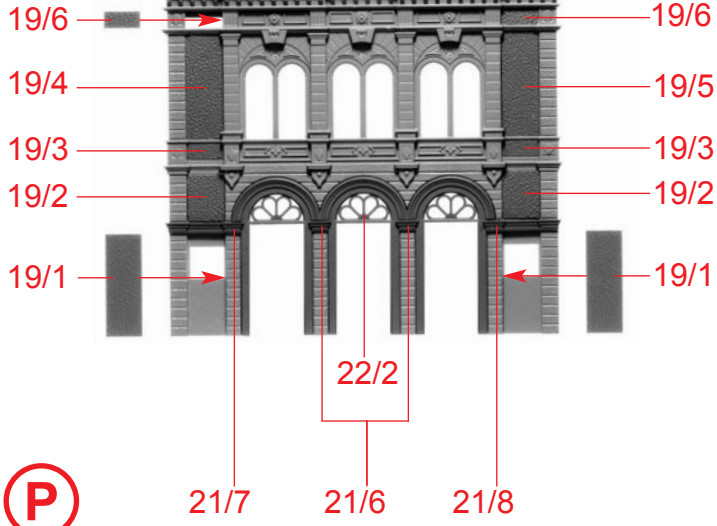

Deco 13

Fensterfolie  
Window foil  
Feuille transparente  
Vensterfolie

11/1

19/7

20/2 20/1

22/6 22/6

nicht kleben  
do not glue  
ne pas coller  
niet lijmen

**P**

3 x

**Q**

Fensterfolie  
Window foil  
Feuille transparente  
Vensterfolie

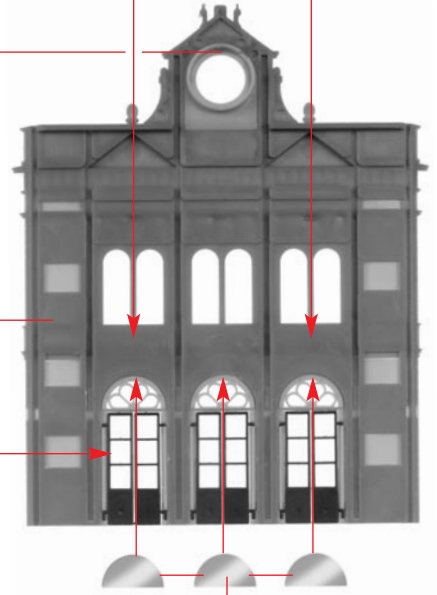
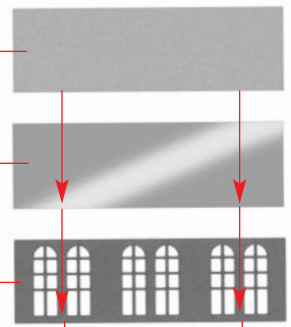

Fensterfolie  
Window foil  
Feuille transparente  
Vensterfolie

**Q** Deco 14

**L**

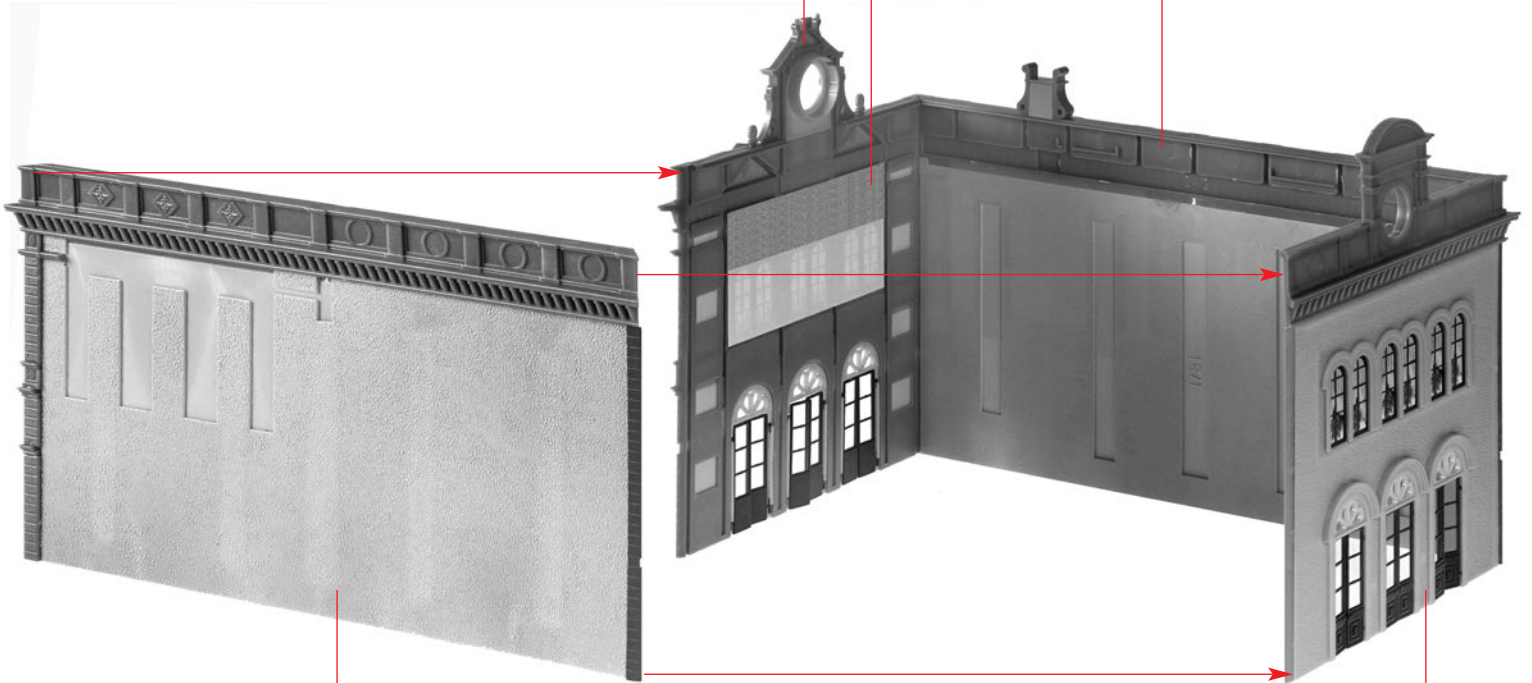

**R**

**I**

**O**

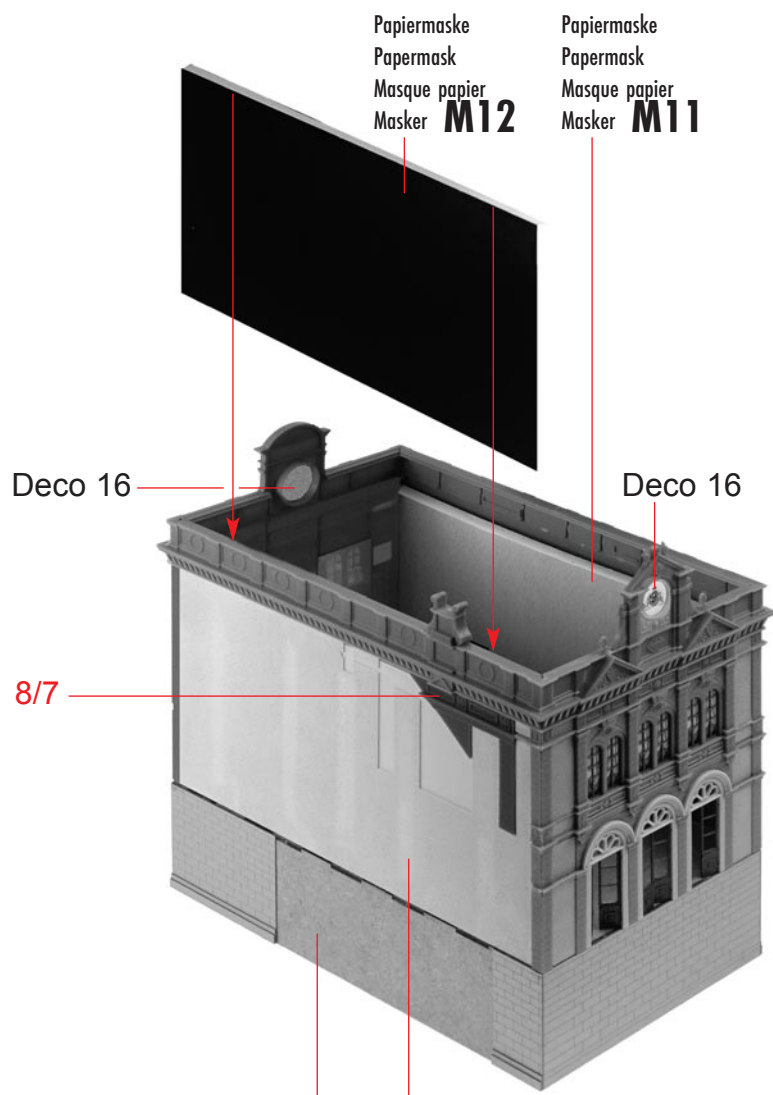

**S** **F** **R**

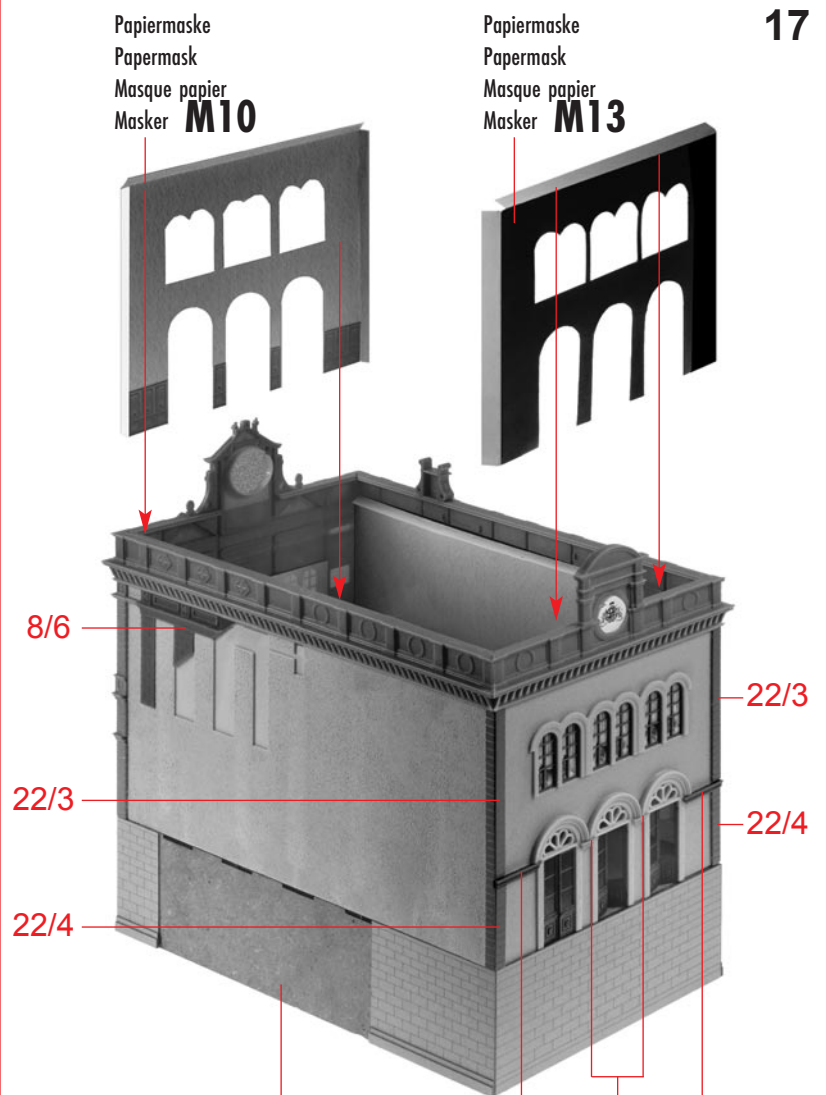

**T** **S** **21/5** **21/3** **21/4**

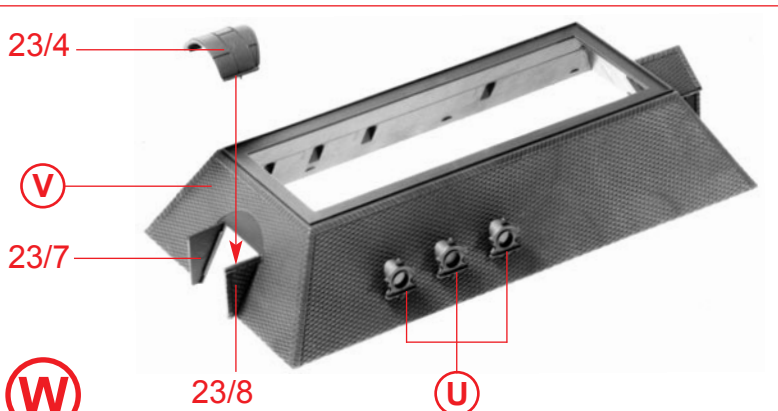
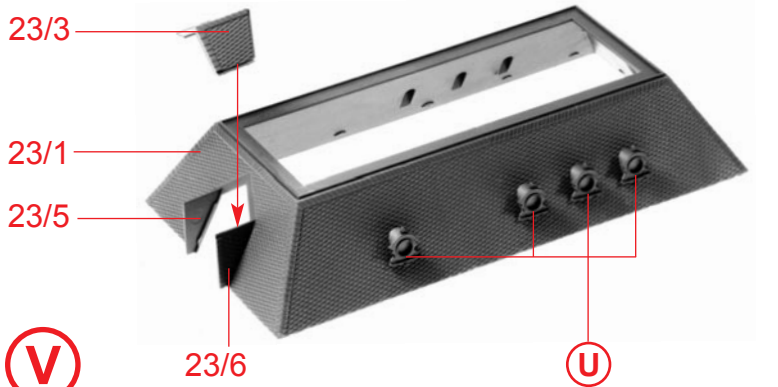
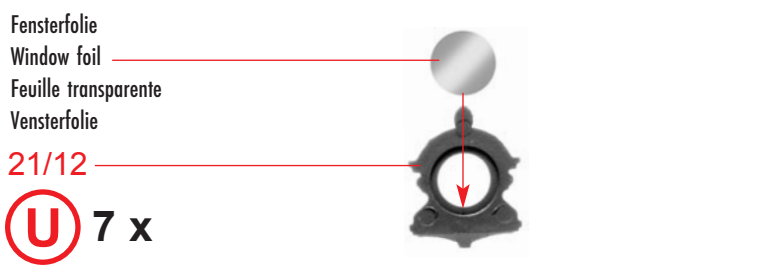

**W** **U**

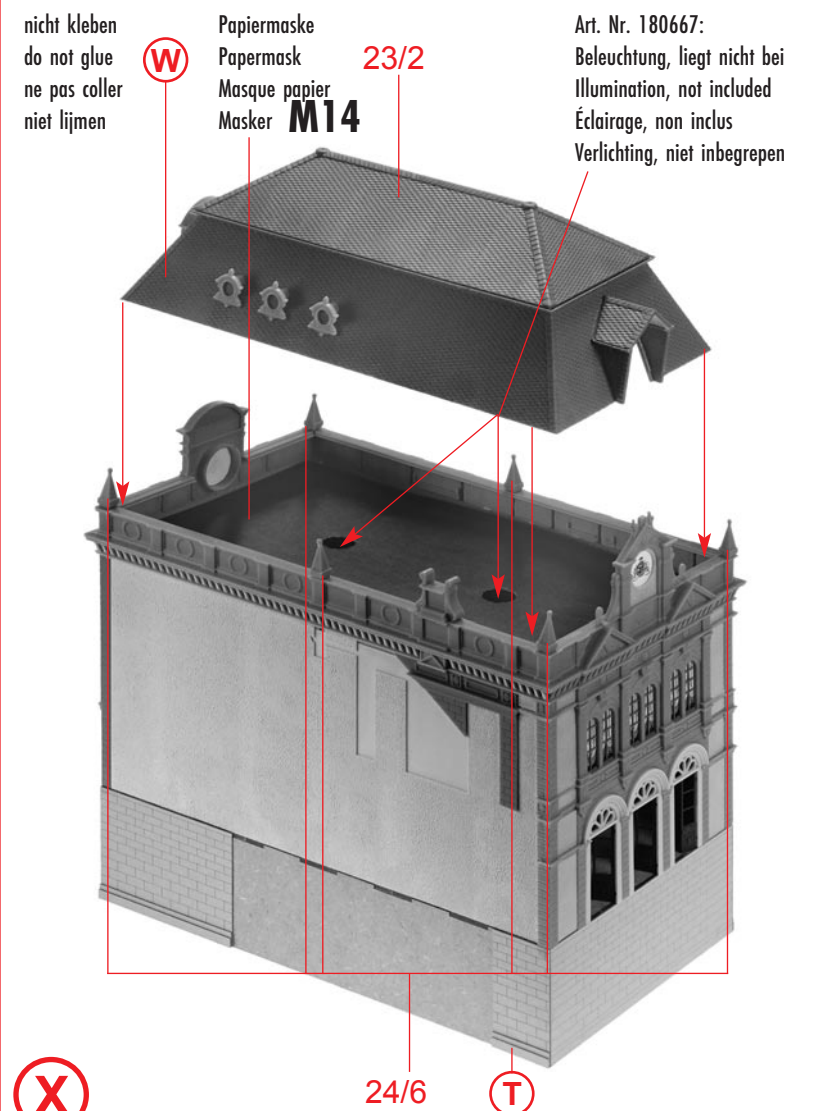

**X** **24/6** **T**

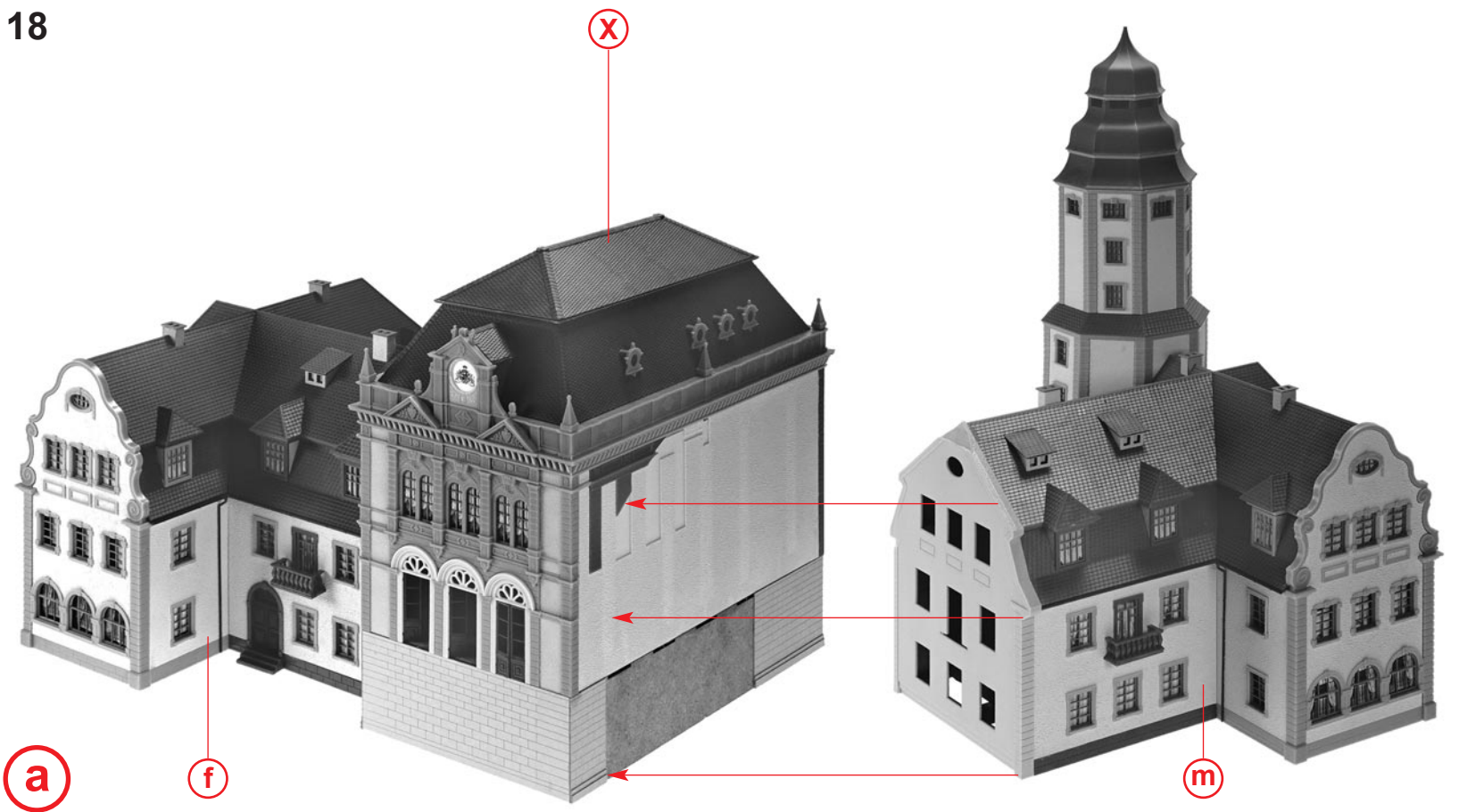

**a**

**f**

**m**

**x**

2/4

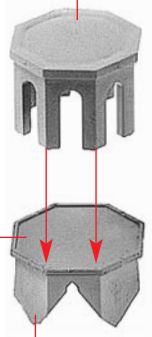

4/9

4/3

**b**

4/8

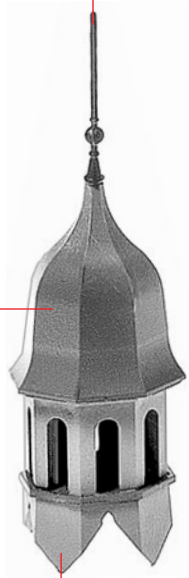

4/4

**b**

**c**

13/5

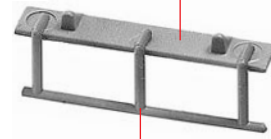

26/12

**d** 2 x

17/24



**e**

26/14

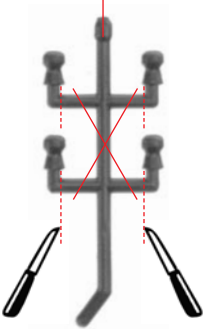

**f**

20/13

20/12

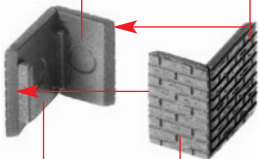

3 x

**g**

20/12

20/13

21/9



**g**

**h**

24/11



**g**

**i**

21/10

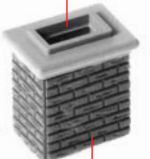

**g**

**j**

d 26/11

f 24/10

8/5

17/27

8/4

26/11

d

f

19

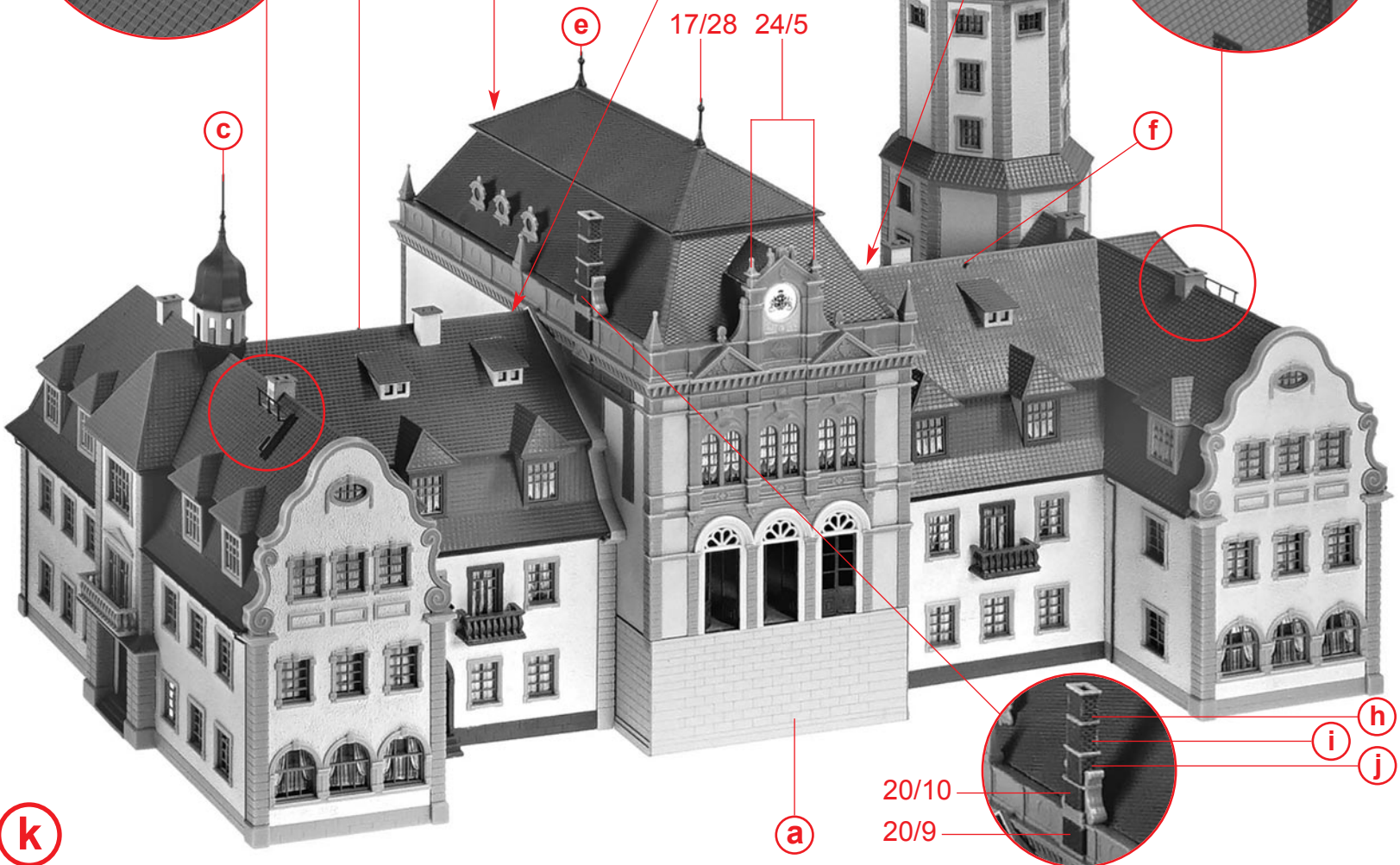
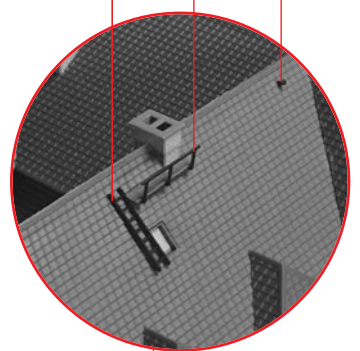
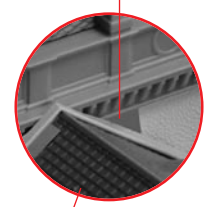
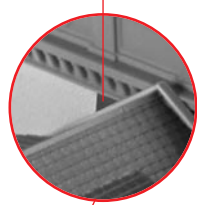
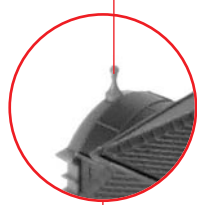
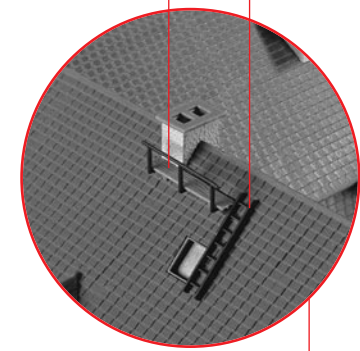

k

a

20/10  
20/9

i

h

j

Lasercut-Kleber verwenden.  
Use Lasercut glue.  
Utilisez la colle Lasercut.  
Gebruik Lasercutlijm.

10/9

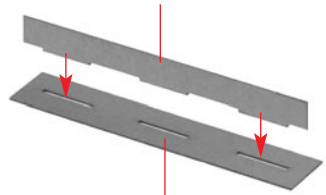

10/10

l 4 x

10/11



10/12

m

Lasercut-Kleber verwenden.  
Use Lasercut glue.  
Utilisez la colle Lasercut.  
Gebruik Lasercutlijm.

Lasercut-Kleber verwenden.  
Use Lasercut glue.  
Utilisez la colle Lasercut.  
Gebruik Lasercutlijm.

10/8

10/8

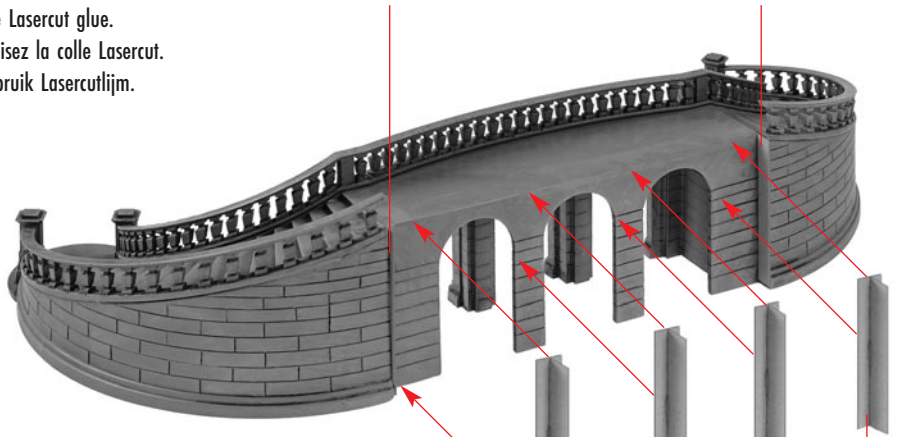

n

l

l

l

l

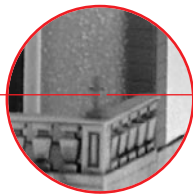
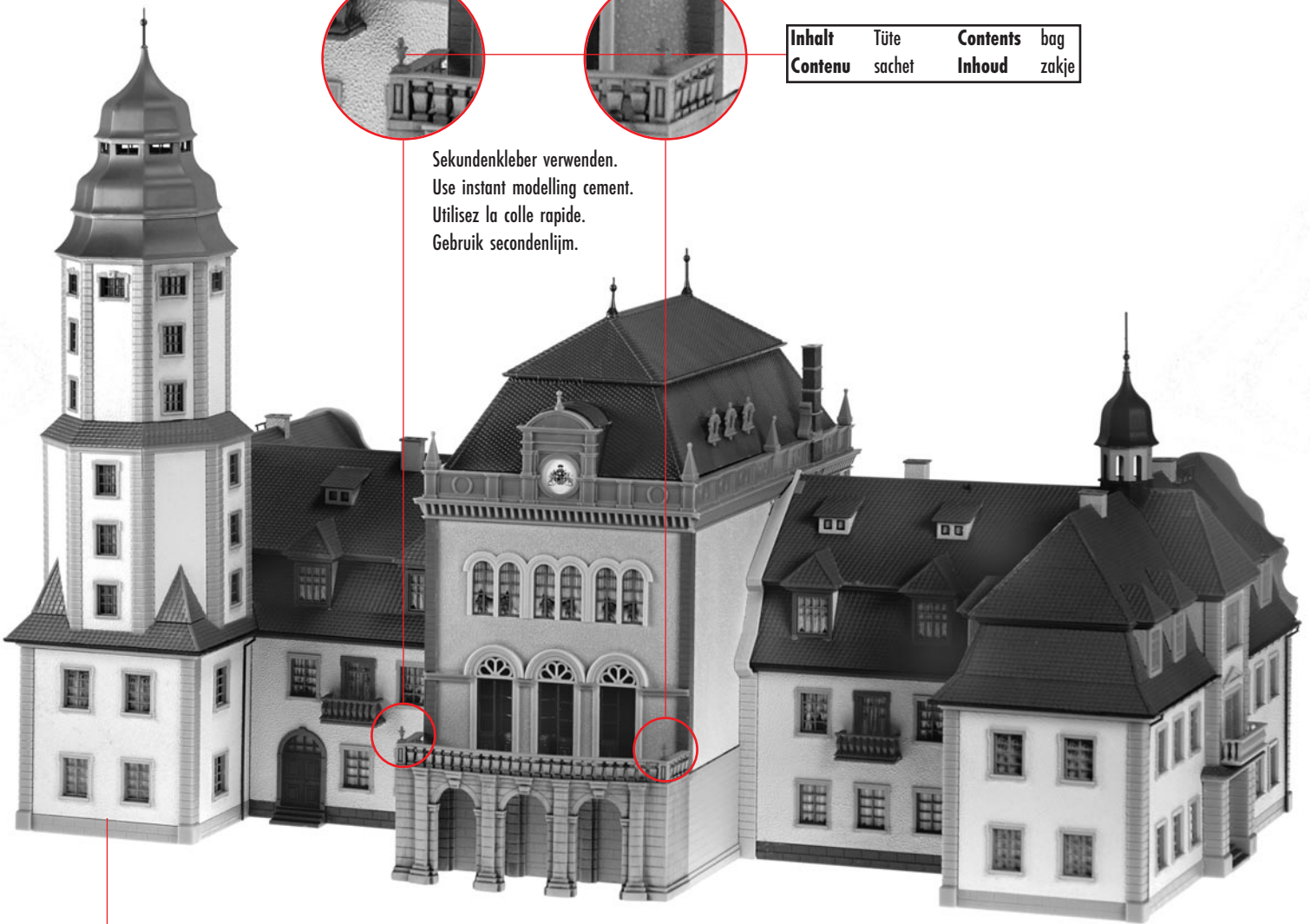

Inhalt	Tüte	Contents	bag
Contenu	sachet	Inhoud	zakje

Sekundenkleber verwenden.  
Use instant modelling cement.  
Utilisez la colle rapide.  
Gebruik secondenlijm.

**o**

**k**

Sekundenkleber verwenden.  
Use instant modelling cement.  
Utilisez la colle rapide.  
Gebruik secondenlijm.

Inhalt	Tüte	Contents	bag
Contenu	sachet	Inhoud	zakje

4 x

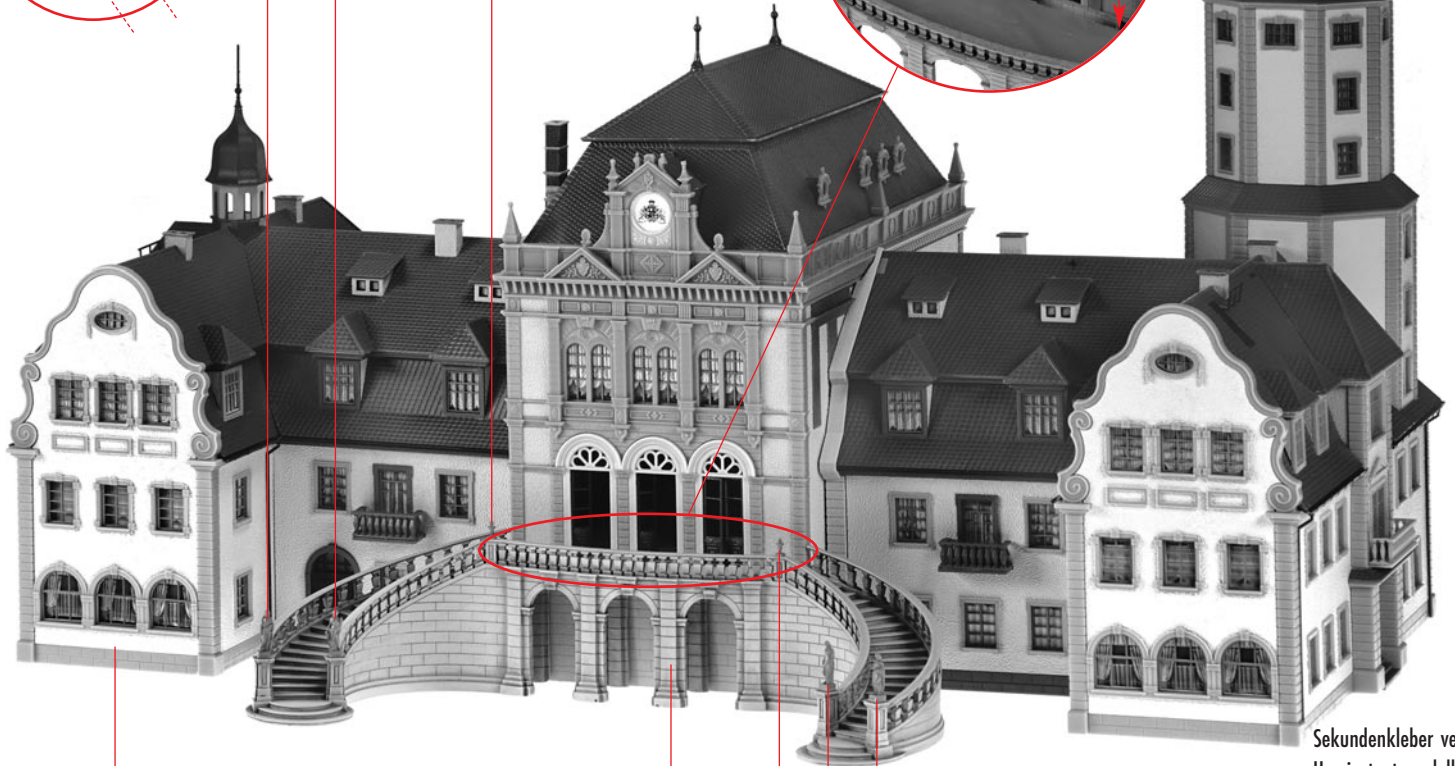
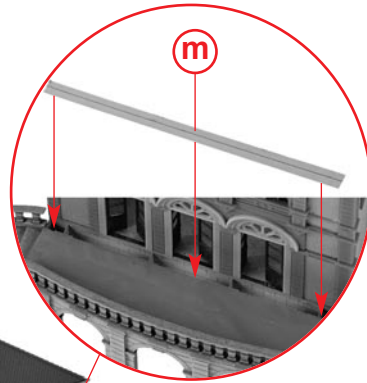
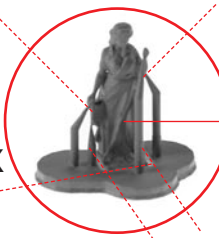

**p**

**o**

**n**

Inhalt	Tüte	Contents	bag
Contenu	sachet	Inhoud	zakje

Sekundenkleber verwenden.  
Use instant modelling cement.  
Utilisez la colle rapide.  
Gebruik secondenlijm.