

FÖRDERANLAGE »MARIENSCHACHT«

FALLER®

»MARIENSCHACHT« MINE-HEADGEAR

PUITS D'EXTRACTION »MARIENSCHACHT«

OPHAALINSTALLATIE »MARIENSCHACHT«

Art. Nr. 130945

D

Machen Sie sich bitte vor Beginn des Bastelns mit dem Bausatzinhalt und der Anleitung vertraut und prüfen Sie die Vollständigkeit. Im Reklamationsfall gilt die gesetzliche Gewährleistungspflicht. Sollte ein Teil fehlen, übersenden Sie bitte den Teilwunsch und den Kaufbeleg an: Gebr. FALLER GmbH, Kundendienst, Kreuzstraße 9, D-78148 Gütenbach, kundendienst@faller.de. Sollten Sie einmal weitere Ersatzteile benötigen, senden wir Ihnen den benötigten Spritzling, bei Verfügbarkeit, gerne kostenpflichtig zu. Bitte beachten Sie, dass produktionsbedingt Einzelteile übrig bleiben können.

GB

Before building your model, please familiarize yourself with the contents of the kit and the instructions for use, also checking whether the set of parts is complete. In case of any complaint, the legal guarantee obligation shall apply. Should a part be missing, please send the designation of the part required and the receipt documenting your purchase to: Gebr. FALLER GmbH, Kundendienst, Kreuzstraße 9, D-78148 Gütenbach, kundendienst@faller.de.

Should you require further spare parts one day, we shall be pleased to send you, with costs, the required sprue, if it is available. Please note that, on grounds of the production process, some single injection molded parts may be superfluous.

F

Avant de commencer votre modèle, veuillez vous familiariser avec le contenu du kit et la notice d'emploi, et contrôlez que le lot de pièces est complet. En cas de réclamation, il s'appliquera l'obligation de garantie légale. Au cas où une pièce manquerait, veuillez envoyer la désignation de la pièce souhaitée et le bon d'achat à: Gebr. FALLER GmbH, Kundendienst, Kreuzstraße 9, D-78148 Gütenbach, kundendienst@faller.de. Au cas où vous auriez besoin un jour d'autres pièces détachées, nous vous enverrons volontiers la grappe requise, si elle est disponible, contre paiement.

Veuillez noter que, pour des raisons de production, il se peut que des pièces détachées soient superflues.

NL

Maak uzelf vóór het bouwen vertrouwd met de inhoud van het bouwpakket en met de handleiding en controleer de volledigheid.

In geval van reclamatie geldt de wettelijke garantieverplichting. Macht er een onderdeel ontbreken, stuur het verzoek om het gewenste onderdeel en het aankoopbewijs dan naar: Gebr. FALLER GmbH, klantenservice, Kreuzstraße 9, D-78148 Gütenbach, kundendienst@faller.de.

Als u ooit meer reserveonderdelen nodig hebt, sturen wij het benodigde gietstuk, indien beschikbaar, graag tegen betaling naar u op. Let op: om productieredenen kunnen losse onderdelen overblijven.

Für den Zusammenbau des Modells empfehlen wir folgende FALLER-Artikel (sind nicht im Bausatz enthalten):

For the assembly of the kit we recommend following FALLER products (not included in the kit):

Pour l'assemblage du modèle, nous vous recommandons les articles FALLER suivants (non inclus dans le kit):

Om dit model te bouwen adviseren wij de volgende FALLER producten (maken geen deel uit van deze bouwset):

Art. Nr. 170490 | 170492 | 170494
FALLER SUPER-EXPERT | EXPERT | LASERCUT



Art. Nr. 170688
SPEZIAL-SEITENSCHNEIDER



Art. Nr. 170687
FALLER-BASTELMESSER

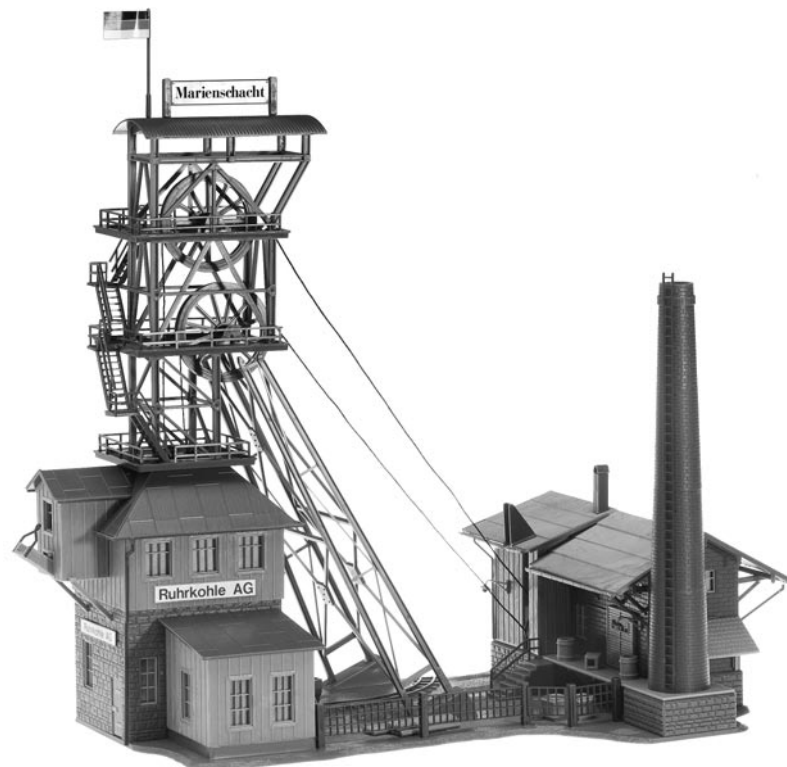

Inhalt	Spritzlinge	1	1 x	5	1 x	9	1 x	13	1 x	17	1 x
Contents	Sprues	2	1 x	6	1 x	10	1 x	14	1 x		
Contenu	Moulages	3	1 x	7	1 x	11	1 x	15	1 x		
Inhoud	Gietstukken	4	1 x	8	1 x	12	1 x	16	1 x		

Sa. Nr. 132 799 0

2

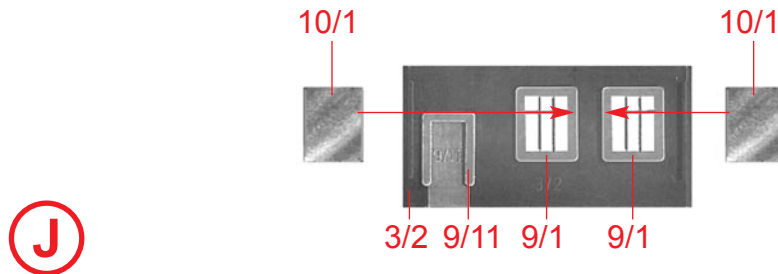
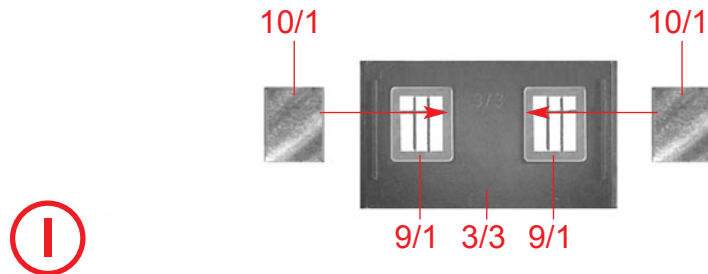
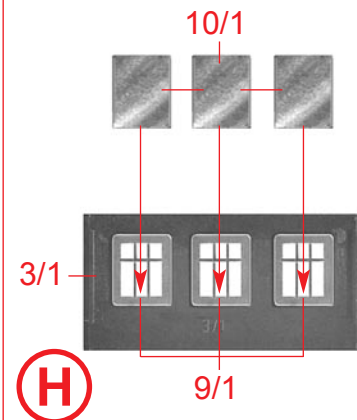
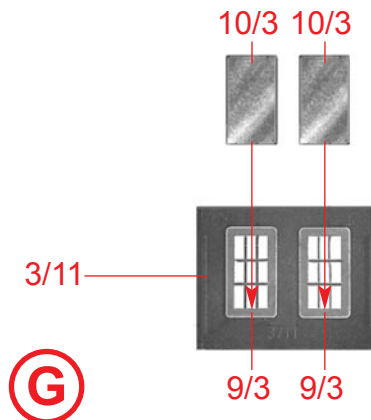
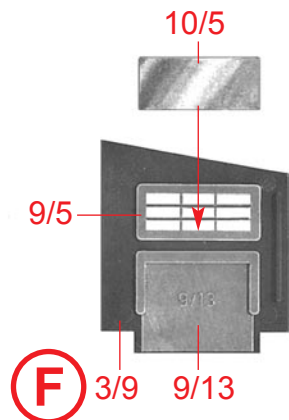
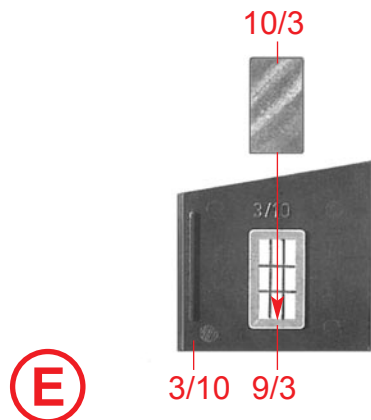
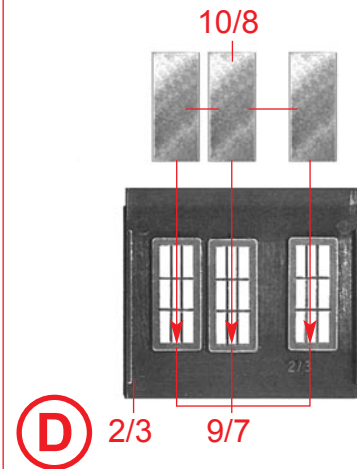
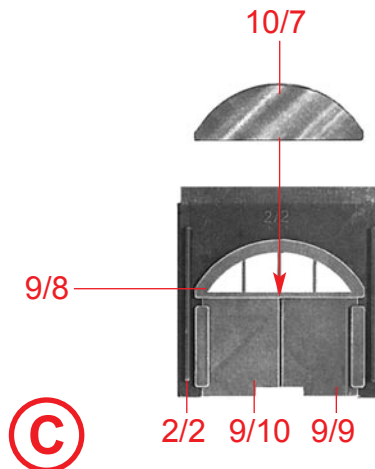
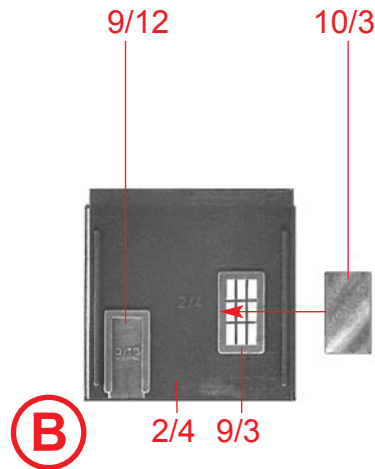
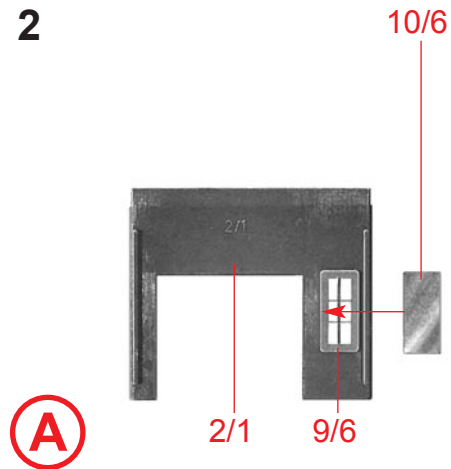

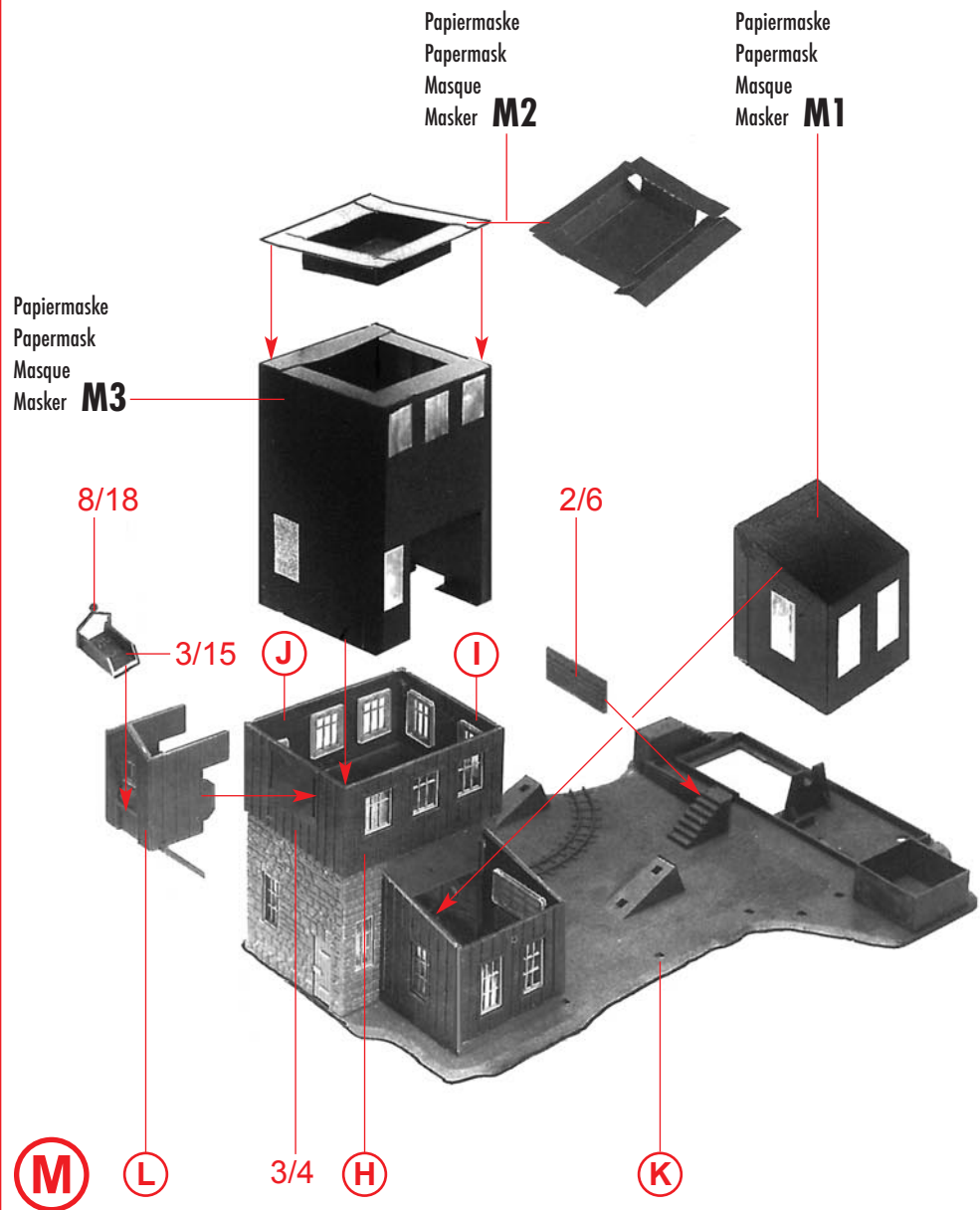
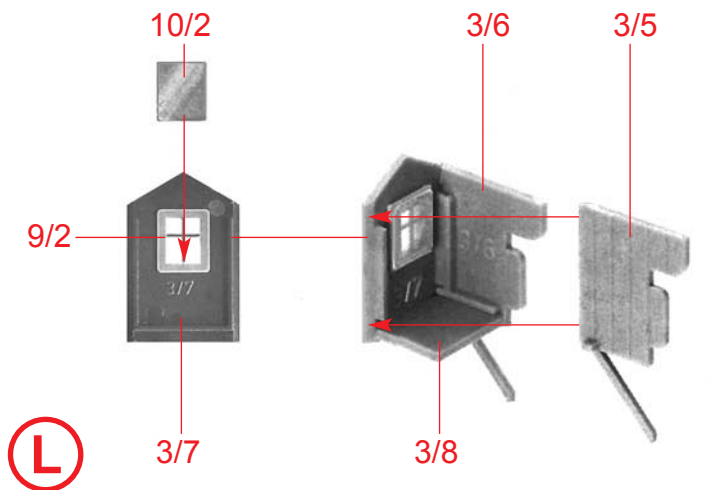
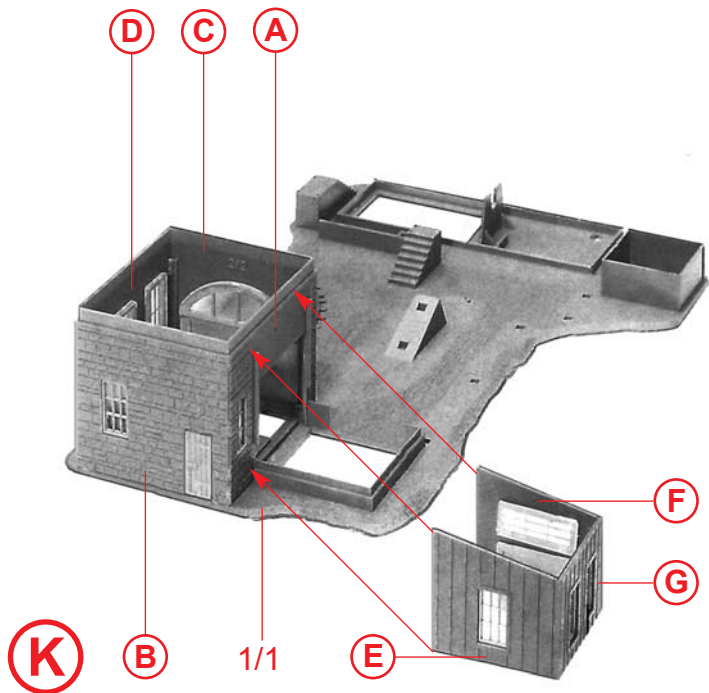

4

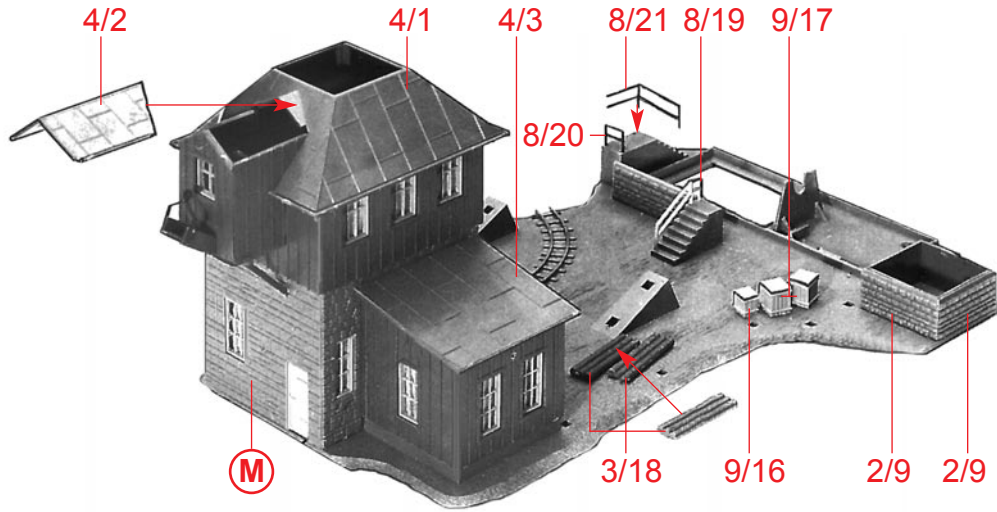

(N)

(M)

Inhalt	Tüte	Contents	bag
Contenu	sachet	Inhoud	zakje



(O)

Montage mit Motor
 Assembly with motor
 Montage avec moteur
 Montage met motor

2/9 2/9

Art. Nr. 180629:
 Motor, liegt nicht bei
 Motor, not included
 Moteur, non jointe
 Motor, niet bijgevoegd

9/21

9/21

8/2

8/1

8/3

6/8

nicht kleben
 do not glue
 ne pas coller
 niet lijmen

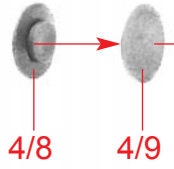

(P)

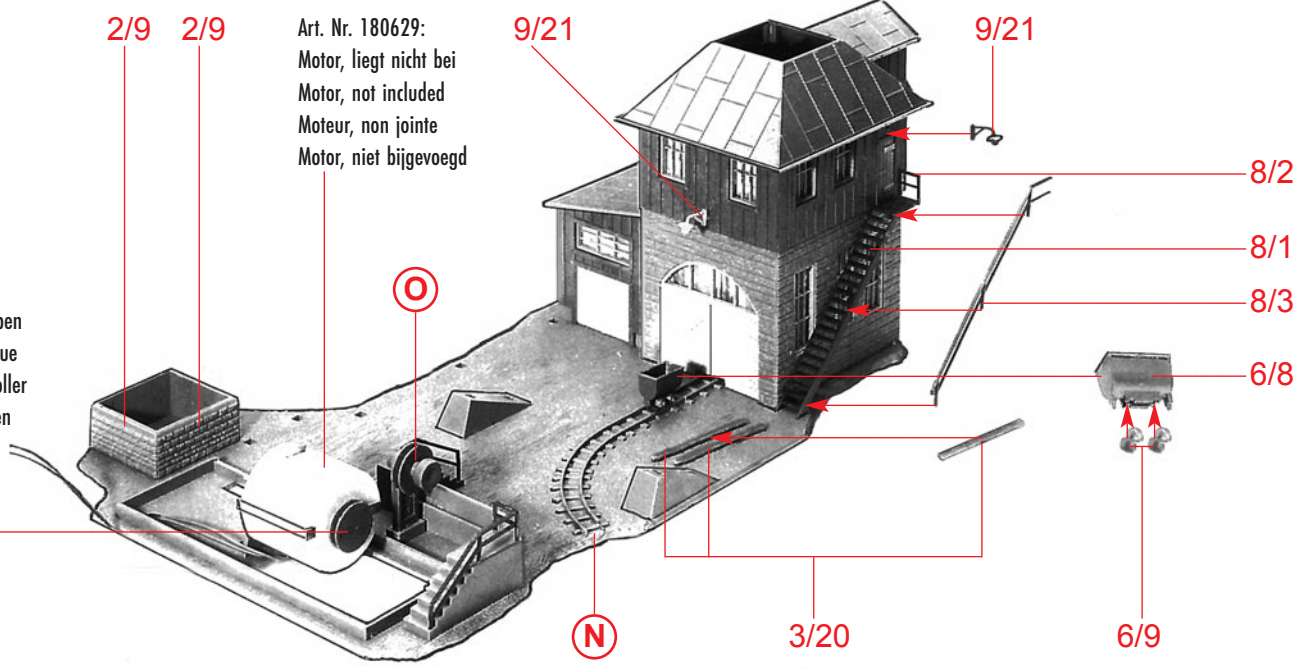

(N)

3/20

6/9

Montage ohne Motor
 Assembly without motor
 Montage sans moteur
 Montage zonder motor

Gummiband
 Rubber band
 Bande élastique
 Elastiek

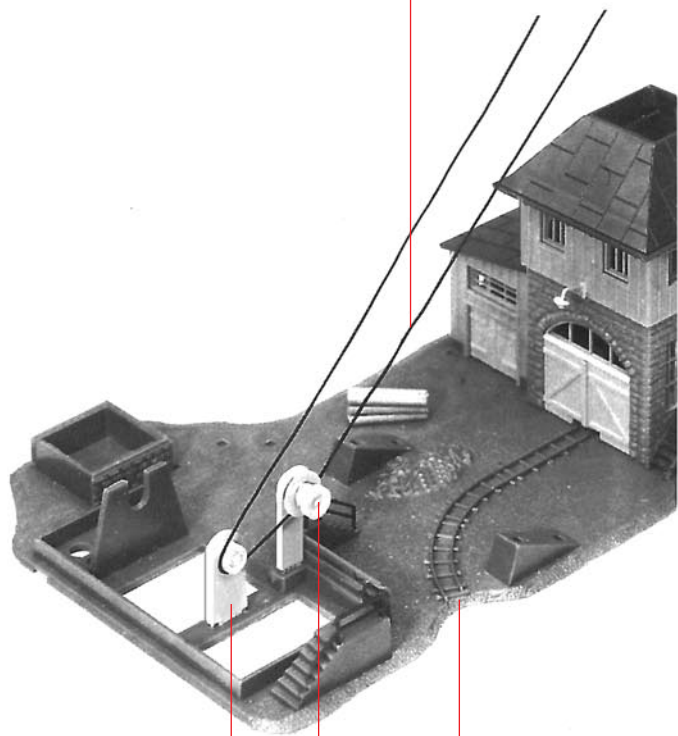

Q

1/2

O

N

R

P

8/27

Deco 2

Deco 3

S

R

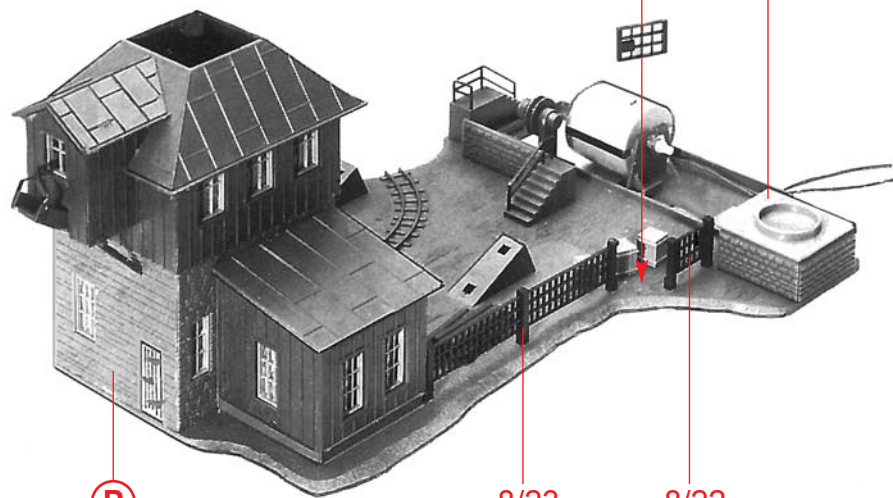

8/24

9/19

5

8/23

8/22

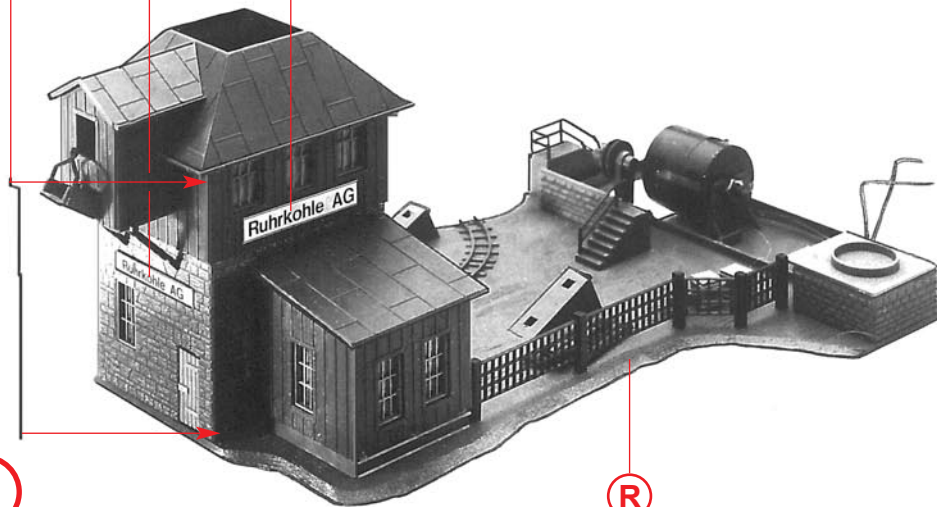

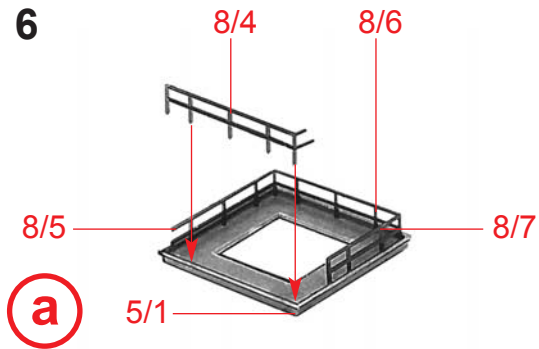
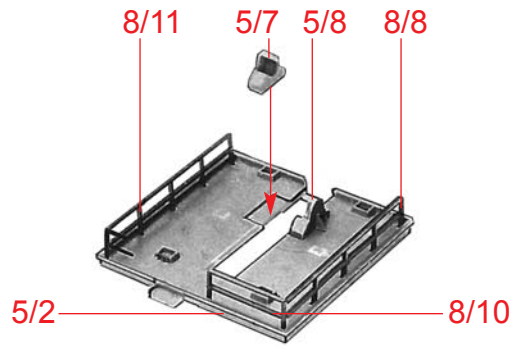
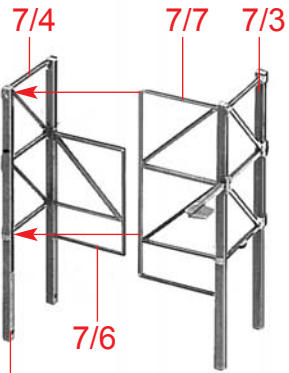
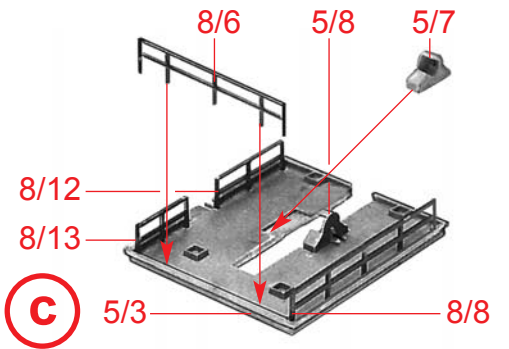
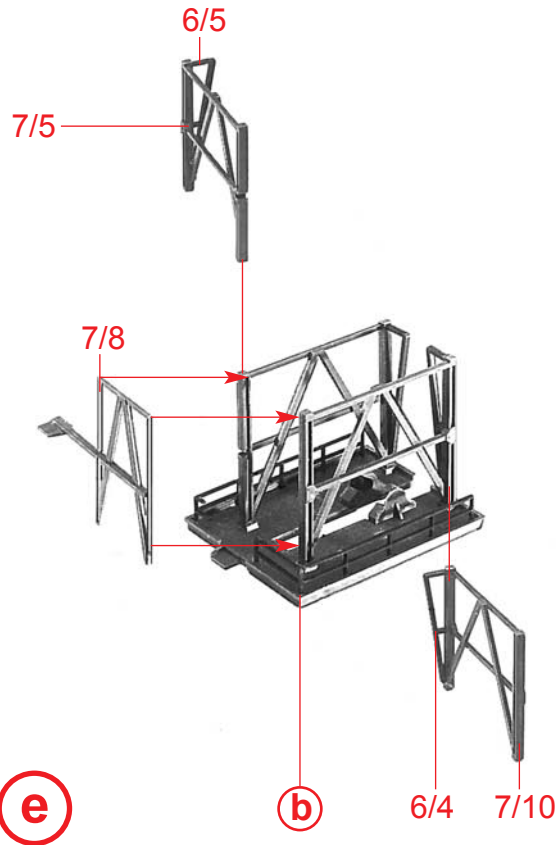
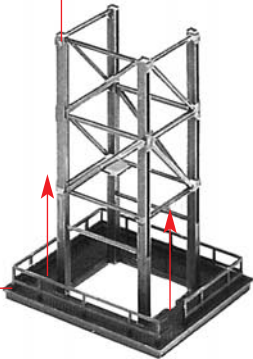
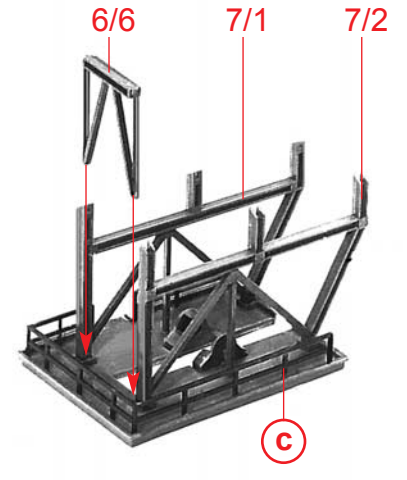
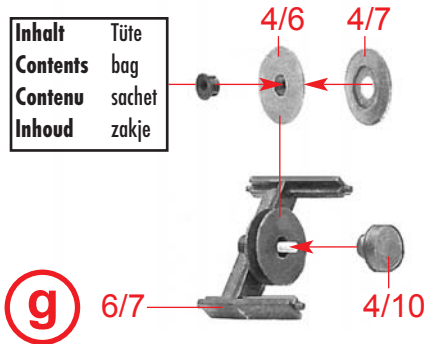
6**b****c****d****e****b****f****g**

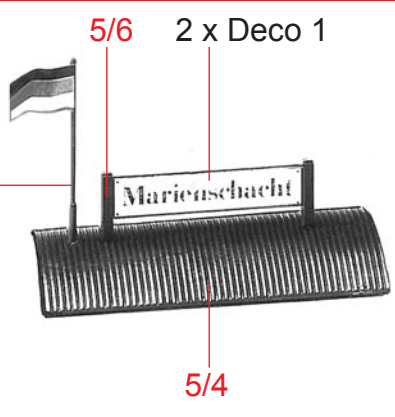
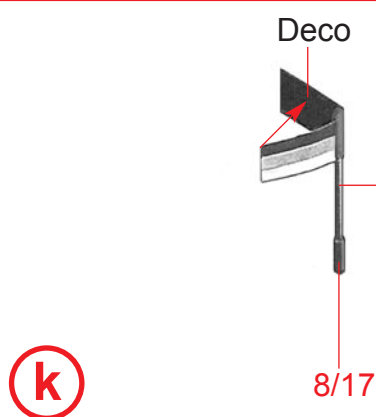
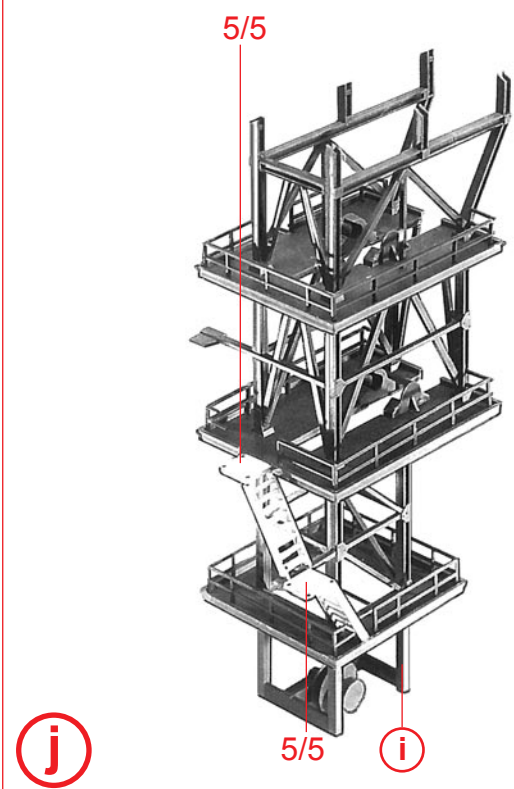
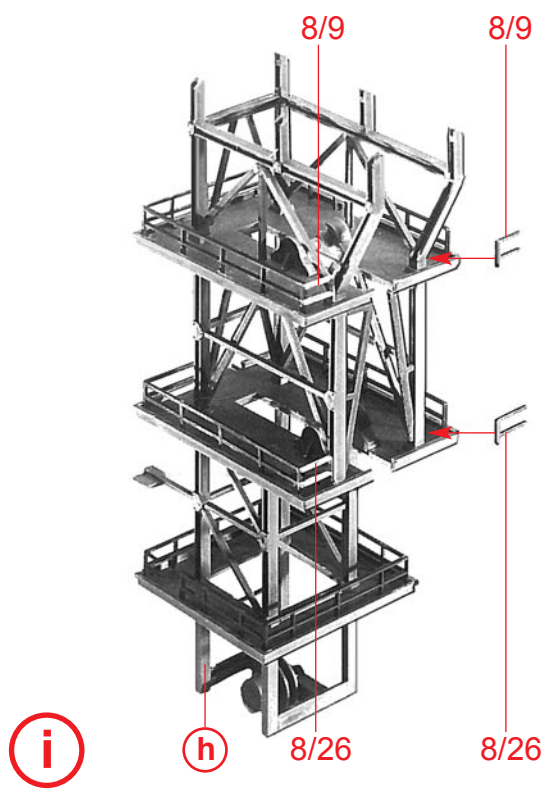
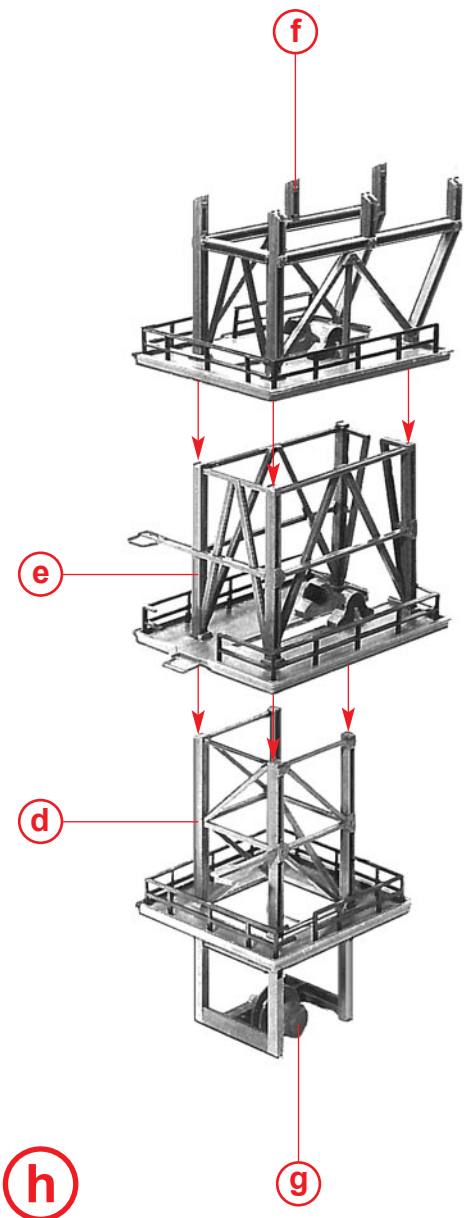

8

5/5

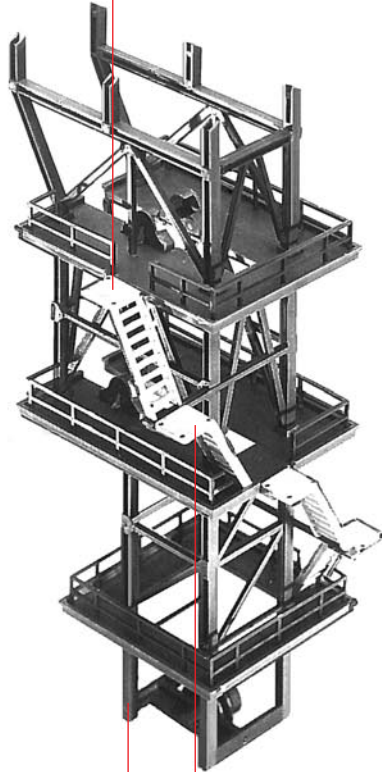

I

j 5/5

Inhalt	Tüte	Contents	bag
Contenu	sachet	Inhoud	zakje

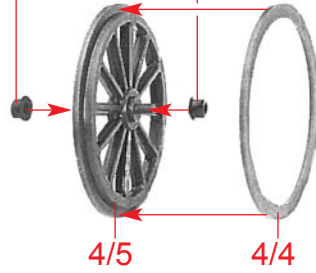

m 2 x

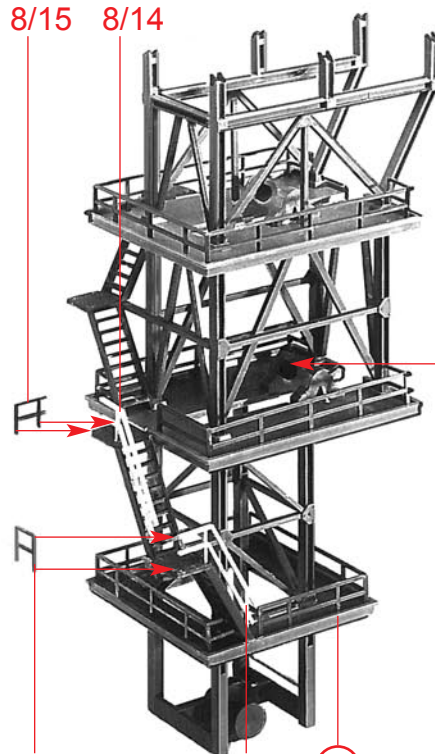

n 8/16

8/14 **I**

m

nicht kleben
do not glue
ne pas coller
niet lijmen



8/15

8/14

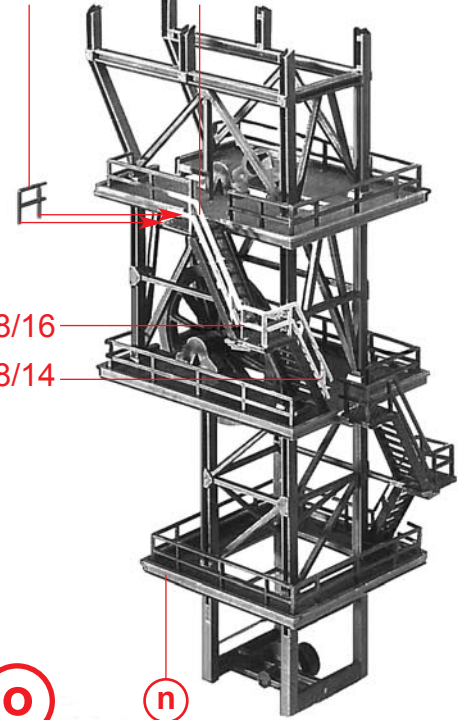

o

n

6/1

6/2

p

6/3

6/3

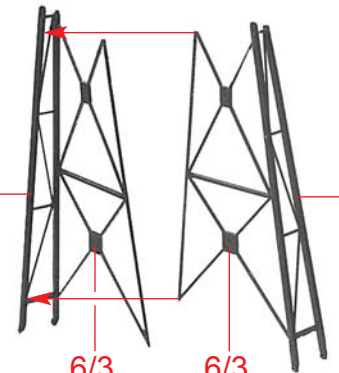

Abbildungen r, s und t zeigen die Montage des Antriebsgummis.

Die Laufrichtung kann beliebig am Schalter des Motors gewählt werden.

Um eventuelle Störungen beheben zu können, darf das Fördergerüst mit den beiden Seilscheiben nicht mit der Schachthalle verklebt werden (Abbildung s).

WICHTIG! Beachten Sie die angegebenen Stellen zum Ölen der Lager.

Diese Stellen nach ca. 20-30 Betriebsstunden mit einem bis zwei Tropfen nicht harzendem, säurefreiem Öl nachgeölt werden (z. B. FALLER 170489).

Figures r, s and t show the installation of the rubber drive.

The direction of travel can be selected as required at the motor switch.

In order to be able to rectify any faults, the conveyor frame with the two pulleys must not be glued to the shaft hall (Figure s).

IMPORTANT! Observe the points indicated for lubricating the bearings.

These points should be re-oiled after approx. 20-30 hours of operation with one or two drops of non-resinous, acid-free oil (e.g. FALLER 170489).

Les illustrations r, s et t montrent le montage du caoutchouc d'entraînement.

Le sens de marche peut être choisi au choix sur l'interrupteur du moteur.

Afin de pouvoir remédier à d'éventuels dysfonctionnements, la structure de transport avec les deux poulies ne doit pas être collée au hall de la cage d'ascenseur (illustration s).

IMPORTANT ! Respectez les endroits indiqués pour huiler les paliers.

Ces endroits doivent être réhuilés après environ 20-30 heures de fonctionnement avec une ou deux gouttes d'huile non résineuse et non acide (par exemple FALLER 170489).

Figuren r, s en t tonen de installatie van de rubberen aandrijving.

De rijrichting kan naar wens worden geselecteerd met de motorschakelaar.

Om eventuele storingen te kunnen verhelpen, mag het transportframe met de twee riemschijven niet aan de ashal worden vastgelijmd (Afbeelding s).

BELANGRIJK! Let op de aangegeven punten voor het smeren van de lagers.

Deze punten moeten na ca. 20-30 bedrijfsuren met een of twee druppels niet-harsende, zuurvrije olie (bijv. FALLER 170489) opnieuw worden ingeolied.

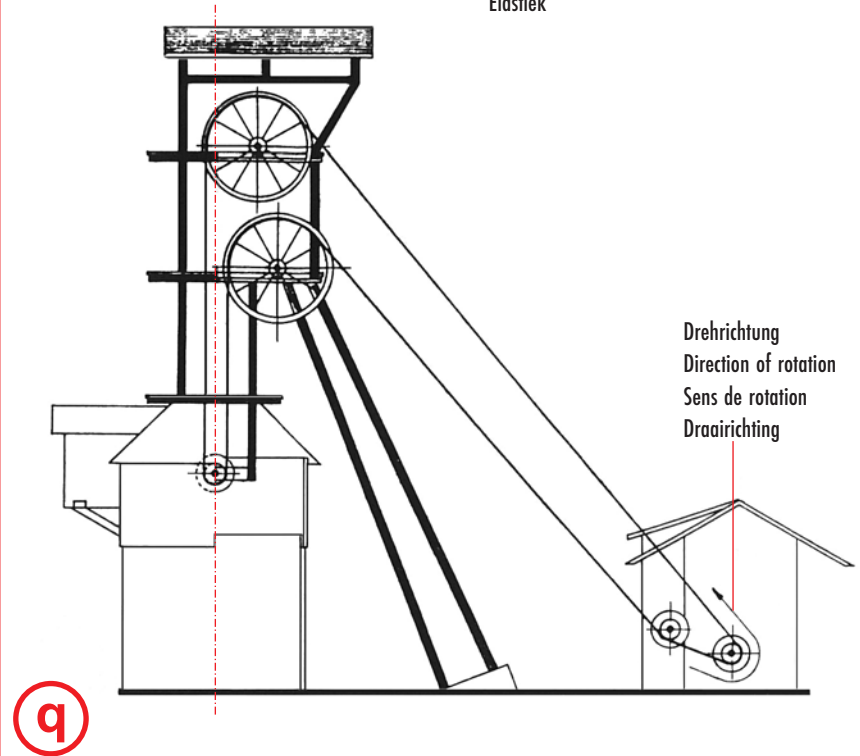
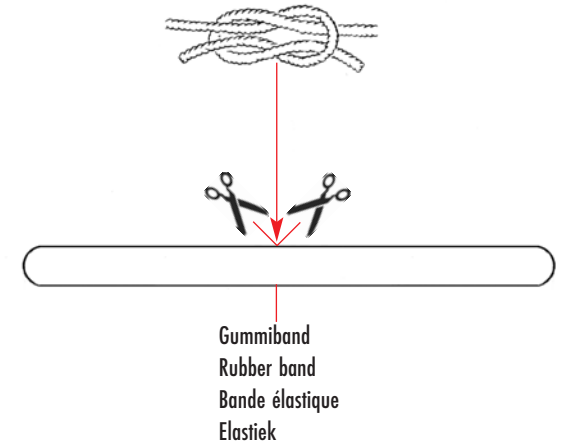

10 Gummiband
Rubber band
Bande élastique
Elastiek

o nicht kleben
do not glue
ne pas coller
niet lijmen

p

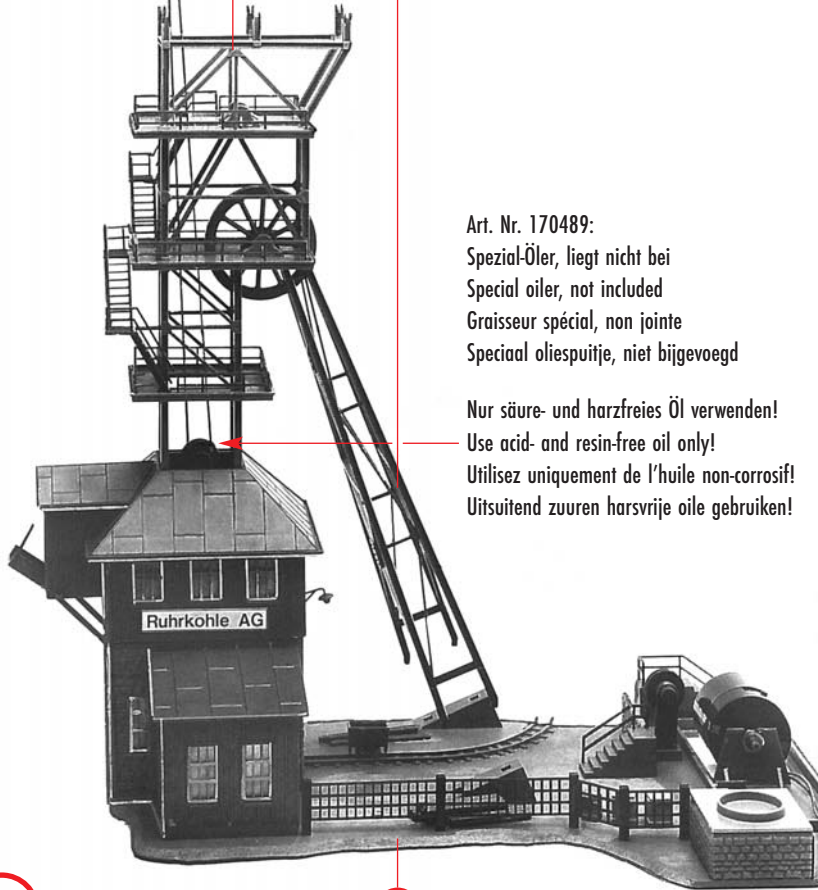

Art. Nr. 170489:
Spezial-Öler, liegt nicht bei
Special oiler, not included
Graisseur spécial, non jointe
Speciaal oliespuitje, niet bijgevoegd

Nur säure- und harzfreies Öl verwenden!
Use acid- and resin-free oil only!
Utilisez uniquement de l'huile non-corrosif!
Uitsluitend zuuren harsvrije olie gebruiken!

r

s

nicht kleben
do not glue
ne pas coller
niet lijmen

Gummiband
Rubber band
Bande élastique
Elastiek

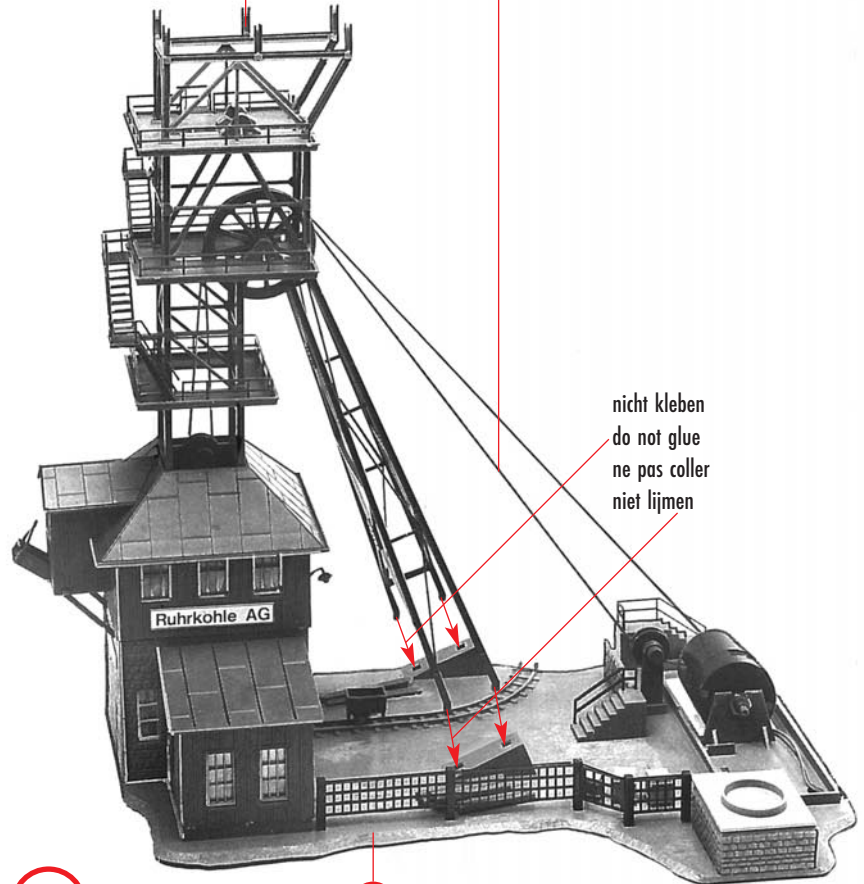

nicht kleben
do not glue
ne pas coller
niet lijmen

s

r

m

nicht kleben
do not glue
ne pas coller
niet lijmen

7/9

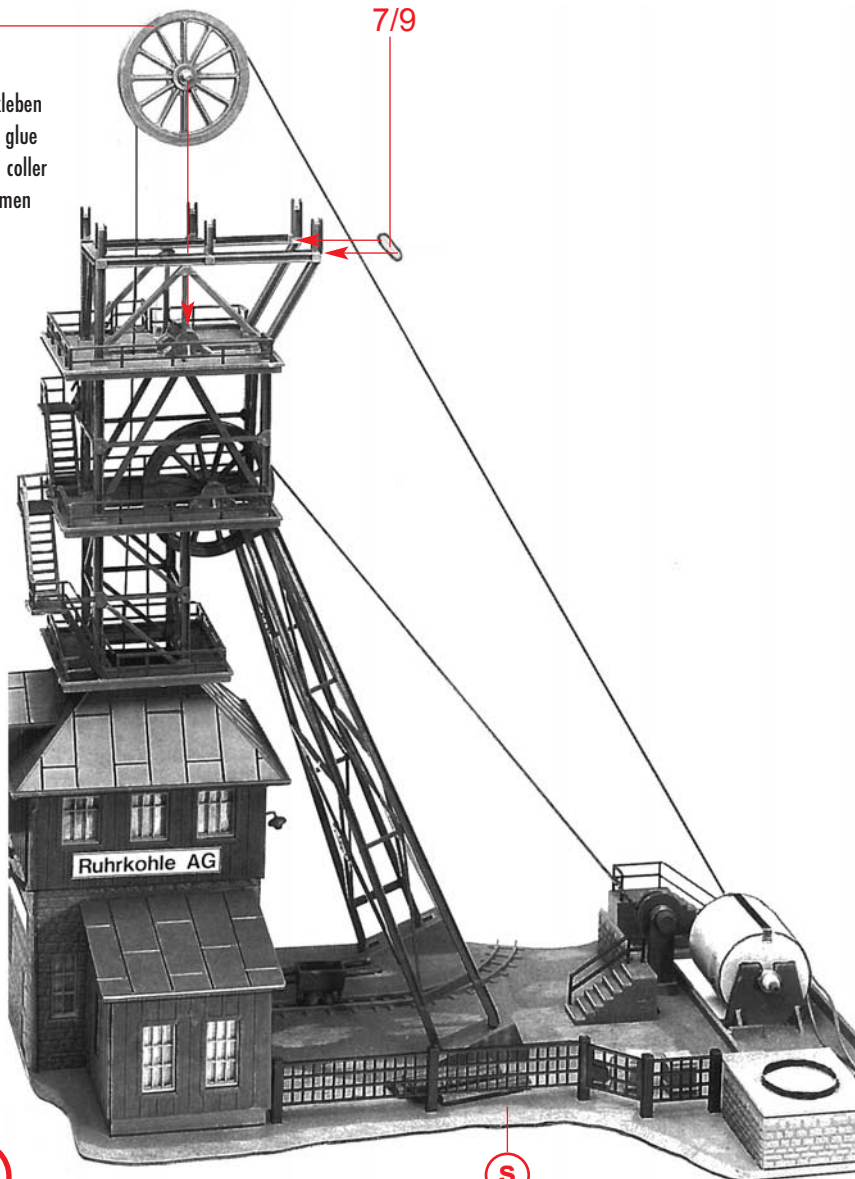

t

s

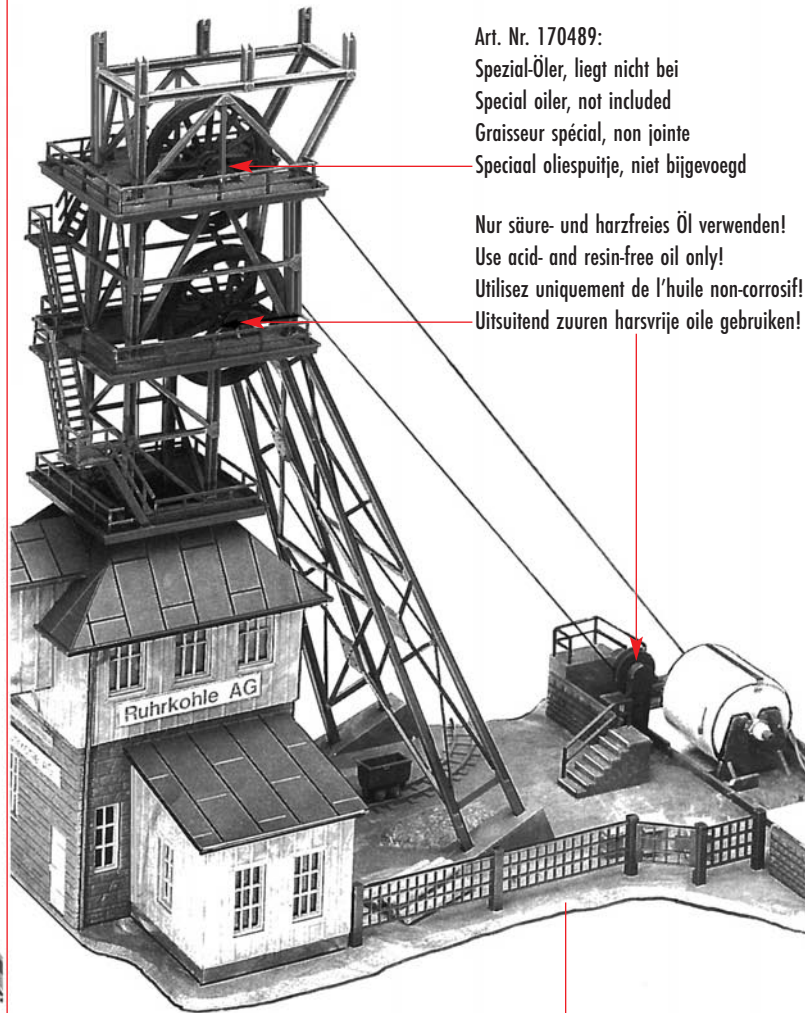

Art. Nr. 170489:
Spezial-Öler, liegt nicht bei
Special oiler, not included
Graisseur spécial, non jointe
Speciaal oliespuitje, niet bijgevoegd

Nur säure- und harzfreies Öl verwenden!
Use acid- and resin-free oil only!
Utilisez uniquement de l'huile non-corrosif!
Uitsluitend zuuren harsvrije olie gebruiken!

u

t

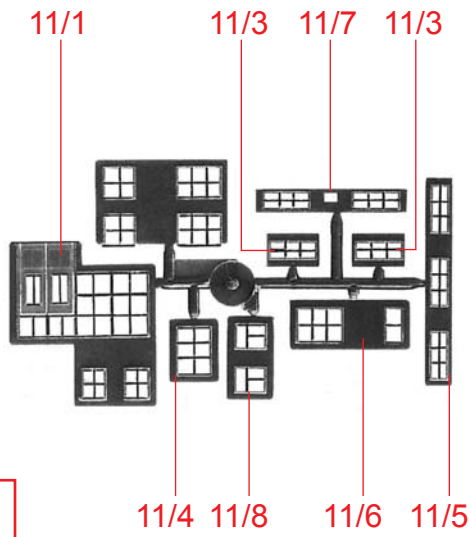
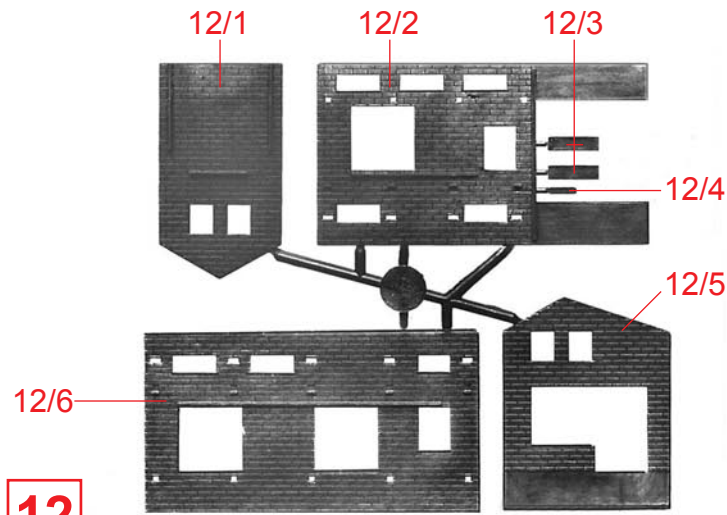
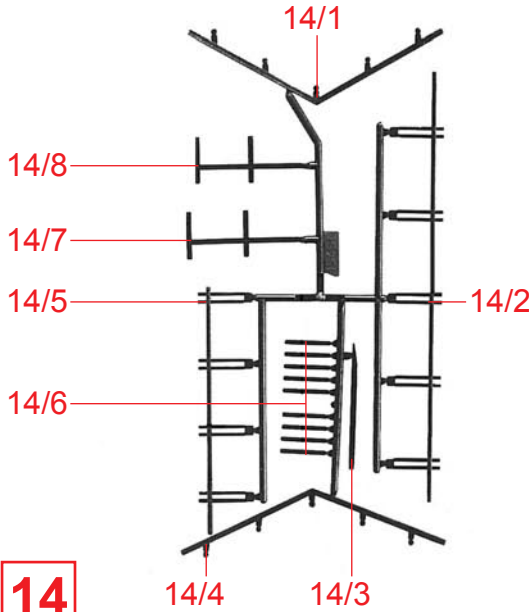
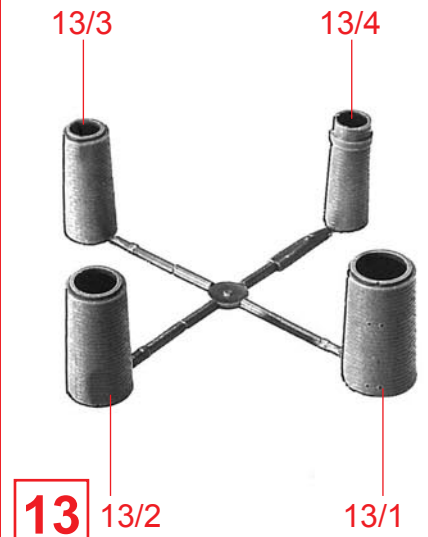
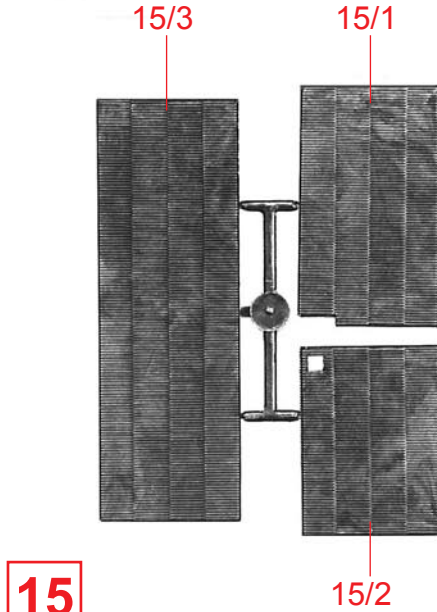
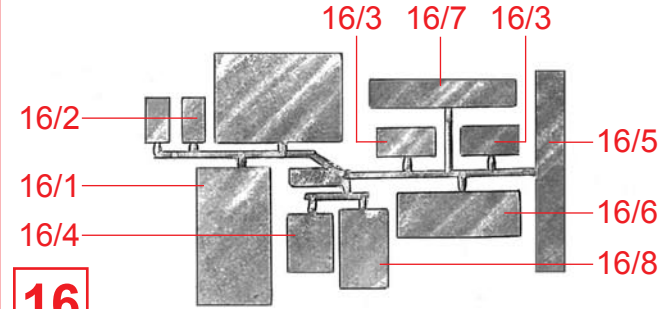
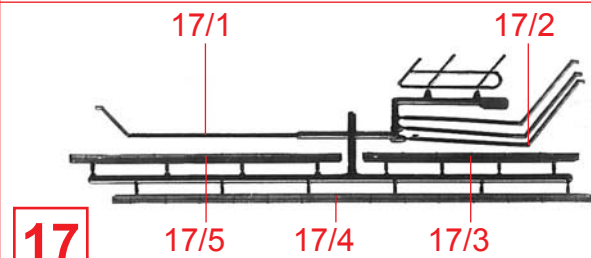
12**11****12****13****14****15****16****17**

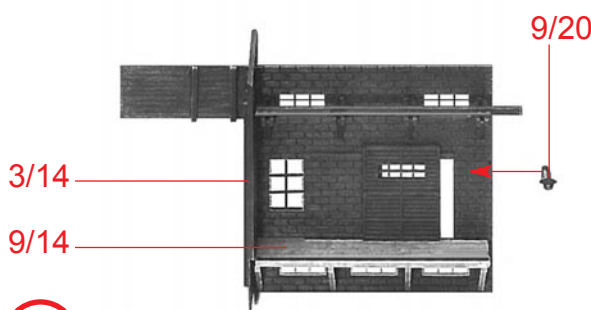
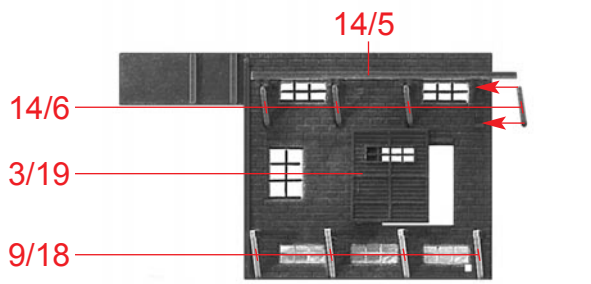
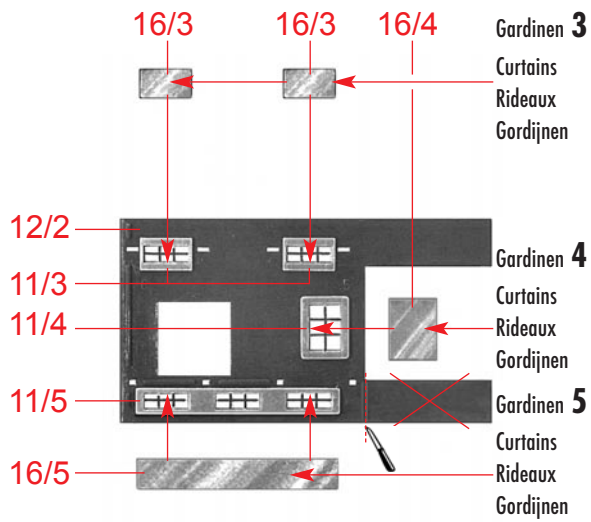

(A)

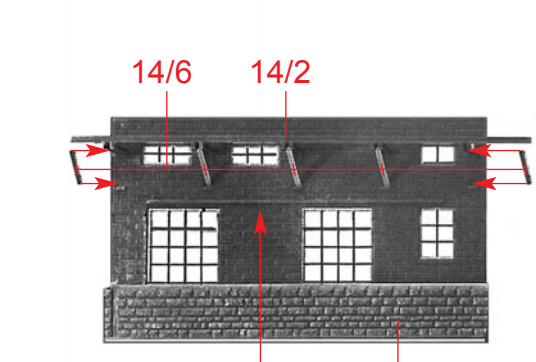
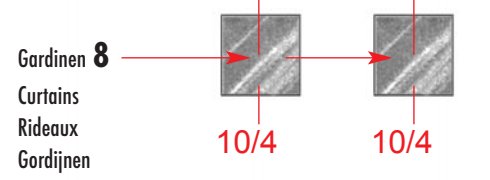
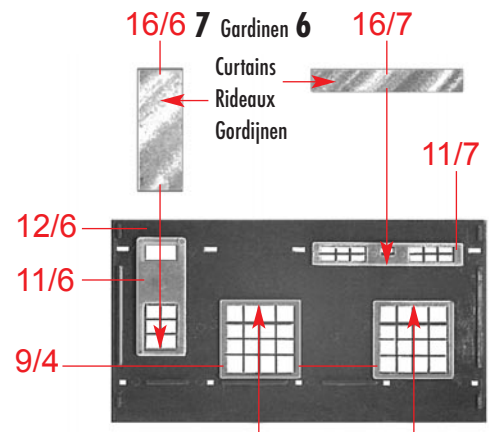

(B)

Deco 4

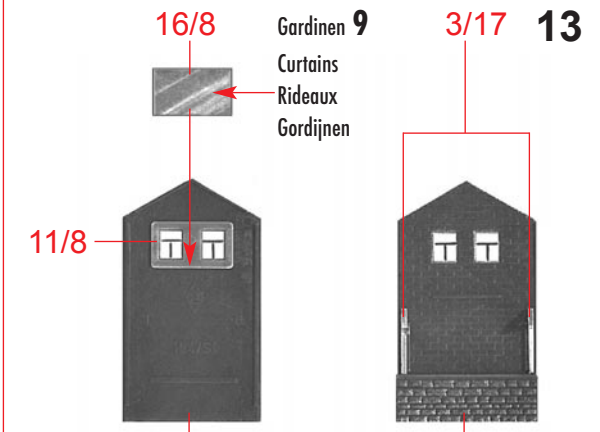

(C)

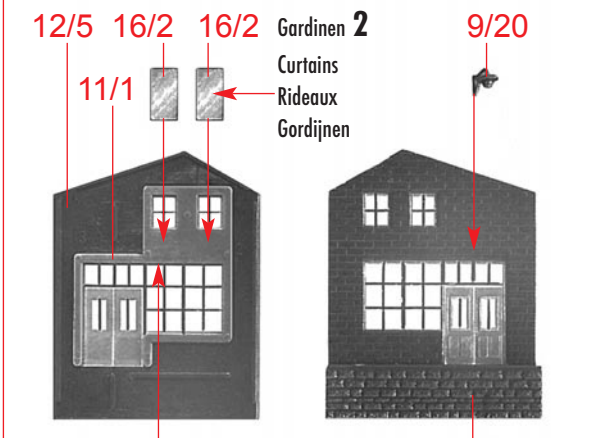

(D)

2/7

14

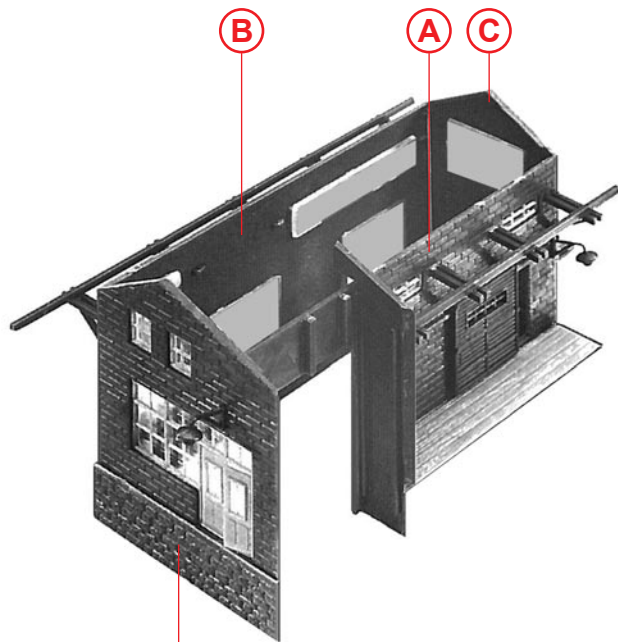

(E)

(D)

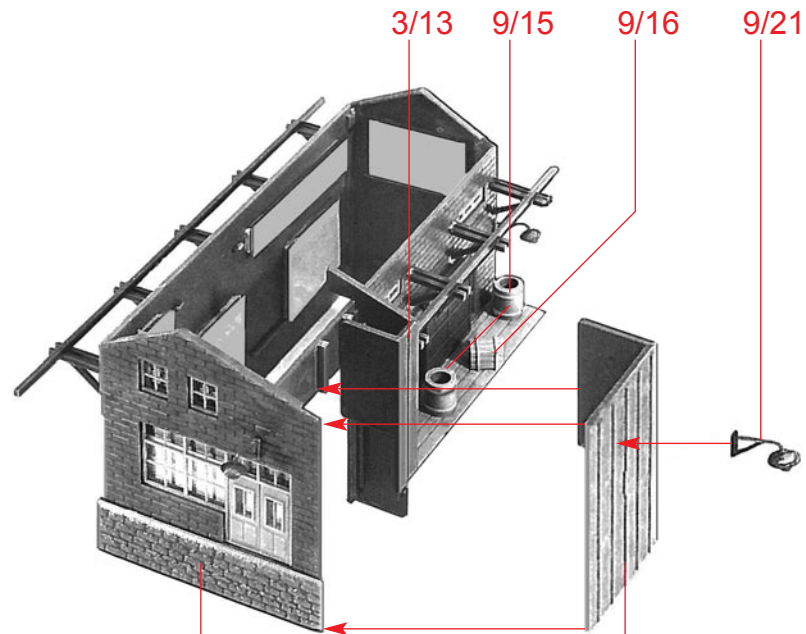

(F)

(E)

3/12

14/8

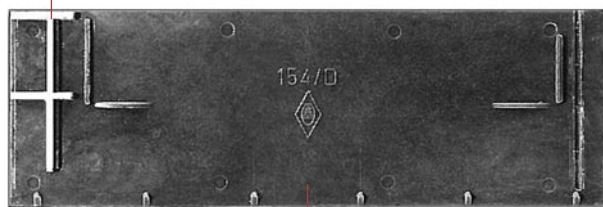

(G)

15/3

14/7

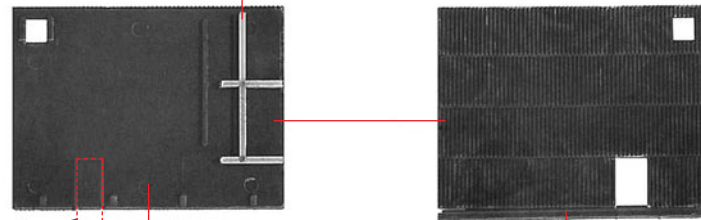

(H)

15/2

17/3

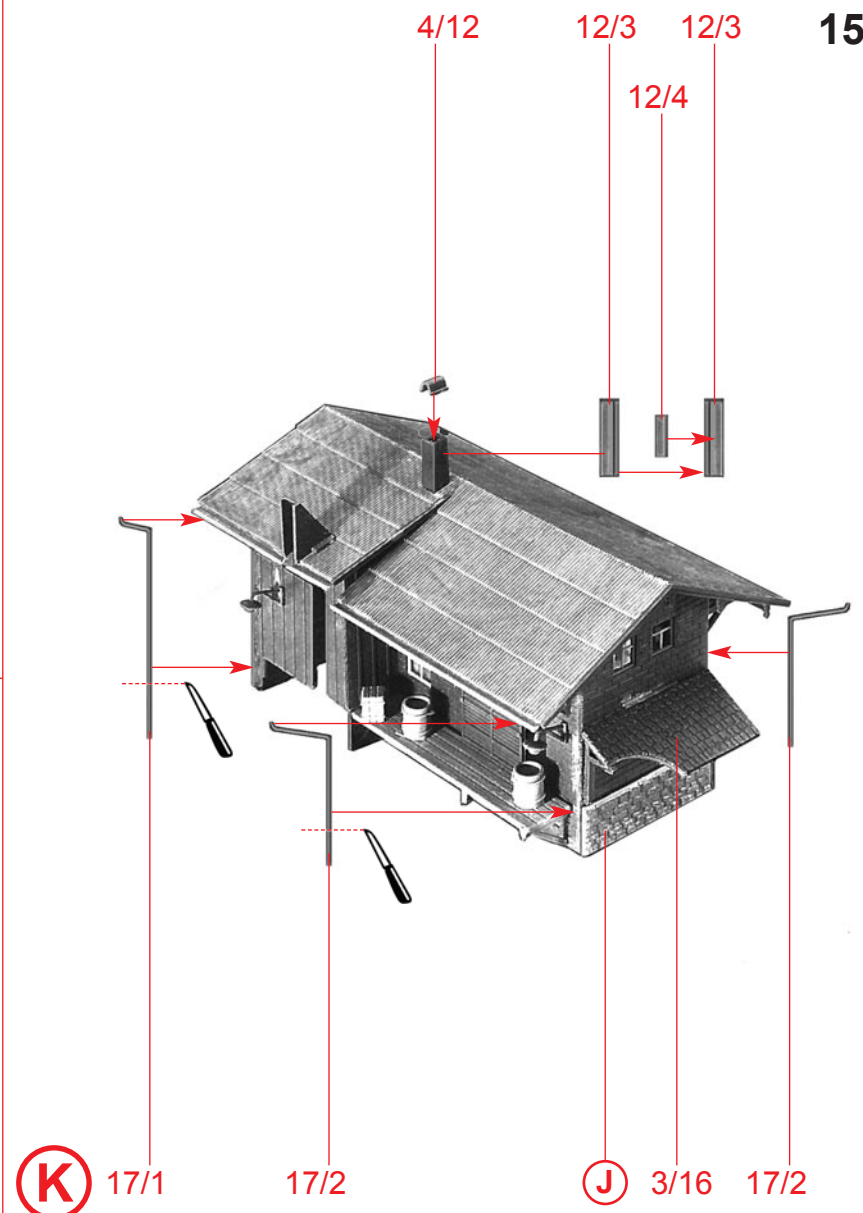
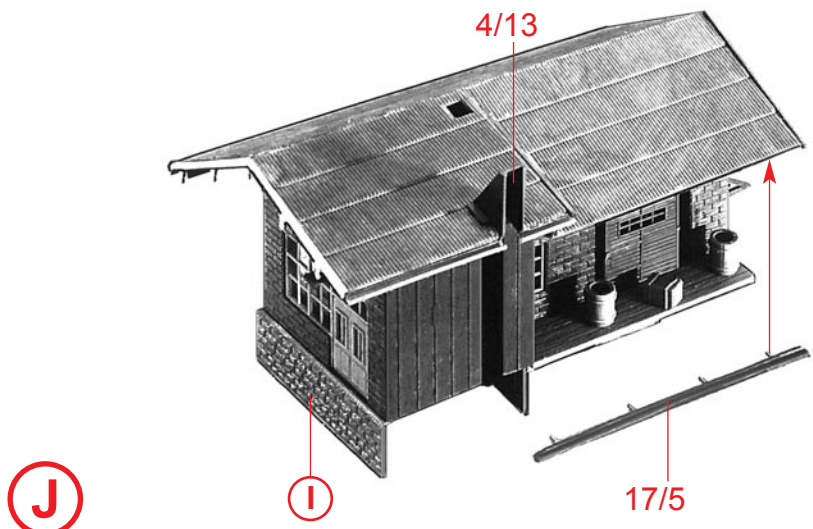
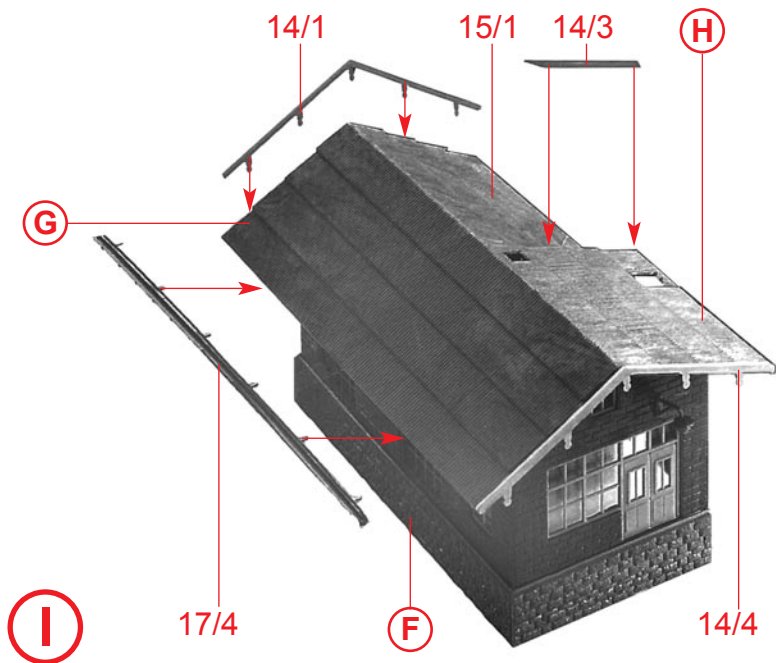

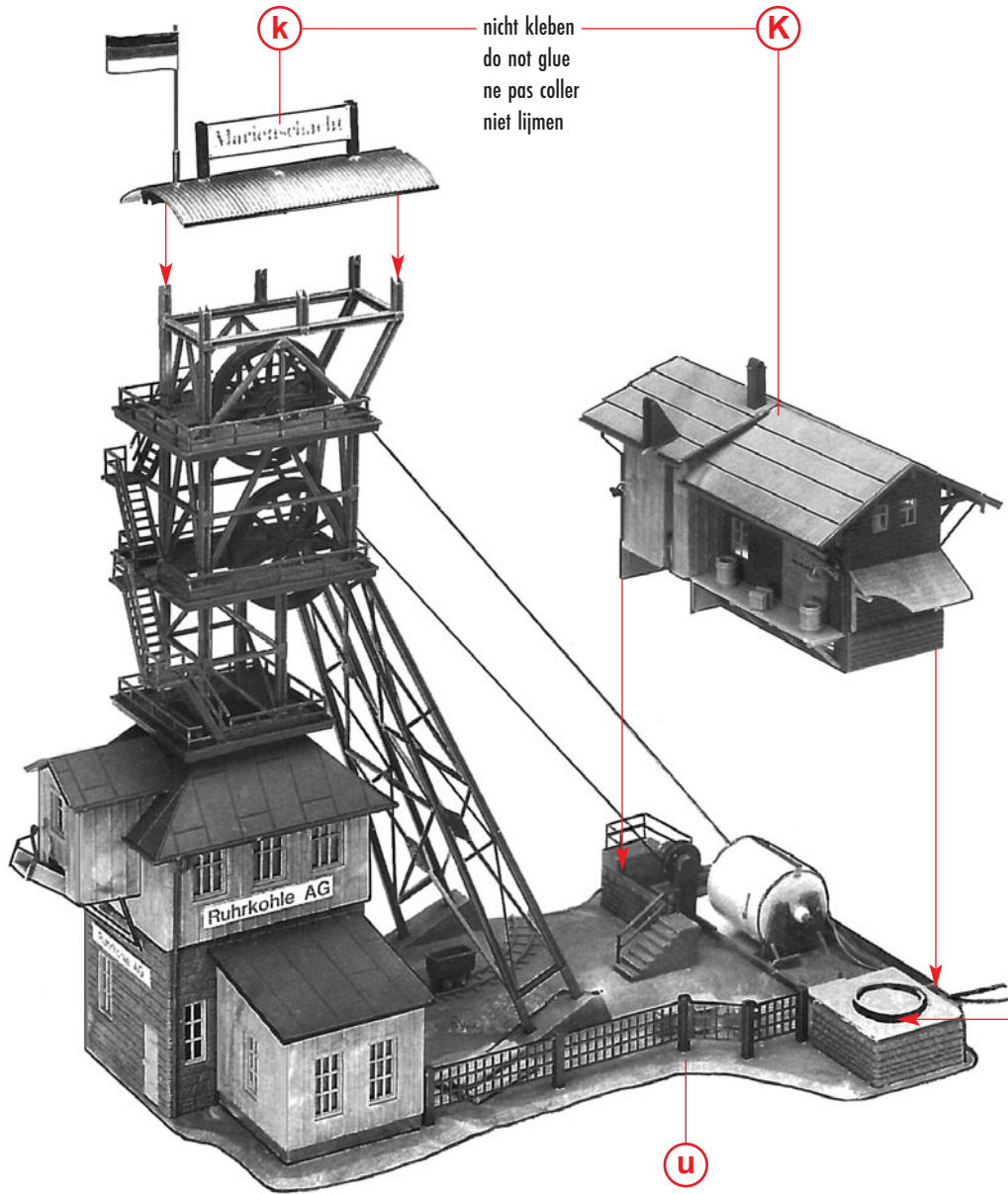

k

nicht kleben
do not glue
ne pas coller
niet lijmen

K

13/4

13/3

13/2

13/1

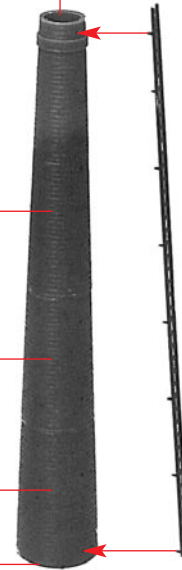

8/25

L

u