

# MOTORRAD-STEILWANDSHOW »SALA MOTOR-DROME«



## »SALA MOTOR-DROME« MOTORCYCLE SHEER WALL SHOW

## NUMÉRO DE PAROI VERTICALE »SALA MOTOR-DROME«

## MOTORFIETS-STEILEWANDSHOW »SALA MOTOR-DROME«

Art. Nr. 140336

**D**

Machen Sie sich bitte vor Beginn des Bastelns mit dem Bausatzinhalt und der Anleitung vertraut und prüfen Sie die Vollständigkeit. Im Reklamationsfall gilt die gesetzliche Gewährleistungspflicht. Sollte ein Teil fehlen, übersenden Sie bitte den Teilwunsch und den Kaufbeleg an: Gebr. FALLER GmbH, Kundendienst, Kreuzstraße 9, D-78148 Gütenbach, kundendienst@faller.de. Sollten Sie einmal weitere Ersatzteile benötigen, senden wir Ihnen den benötigten Spritzling, bei Verfügbarkeit, gerne kostenpflichtig zu. Bitte beachten Sie, dass produktionsbedingt Einzelteile übrig bleiben können.

**GB**

Before building your model, please familiarize yourself with the contents of the kit and the instructions for use, also checking whether the set of parts is complete. In case of any complaint, the legal guarantee obligation shall apply. Should a part be missing, please send the designation of the part required and the receipt documenting your purchase to: Gebr. FALLER GmbH, Kundendienst, Kreuzstraße 9, D-78148 Gütenbach, kundendienst@faller.de. Should you require further spare parts one day, we shall be pleased to send you, with costs, the required sprue, if it is available. Please note that, on grounds of the production process, some single injection molded parts may be superfluous.

**F**

Avant de commencer votre modèle, veuillez vous familiariser avec le contenu du kit et la notice d'emploi, et contrôlez que le lot de pièces est complet. En cas de réclamation, il s'appliquera l'obligation de garantie légale. Au cas où une pièce manquerait, veuillez envoyer la désignation de la pièce souhaitée et le bon d'achat à: Gebr. FALLER GmbH, Kundendienst, Kreuzstraße 9, D-78148 Gütenbach, kundendienst@faller.de. Au cas où vous auriez besoin un jour d'autres pièces détachées, nous vous enverrons volontiers la grappe requise, si elle est disponible, contre paiement. Veuillez noter que, pour des raisons de production, il se peut que des pièces détachées soient superflues.

**NL**

Maak uzelf vóór het bouwen vertrouwd met de inhoud van het bouwpakket en met de handleiding en controleer de volledigheid. In geval van reclamatie geldt de wettelijke garantieverplichting. Mocht er een onderdeel ontbreken, stuur het verzoek om het gewenste onderdeel en het aankoopbewijs dan naar: Gebr. FALLER GmbH, klantenservice, Kreuzstraße 9, D-78148 Gütenbach, kundendienst@faller.de. Als u ooit meer reserveonderdelen nodig hebt, sturen wij het benodigde gietstuk, indien beschikbaar, graag tegen betaling naar u op. Let op: om productieredenen kunnen losse onderdelen overblijven.

Für den Zusammenbau des Modells empfehlen wir folgende FALLER-Artikel (sind nicht im Bausatz enthalten):

For the assembly of the kit we recommend following FALLER products (not included in the kit):

Pour l'assemblage du modèle, nous vous recommandons les articles FALLER suivants (non inclus dans le kit):

Om dit model te bouwen adviseren wij de volgende FALLER producten (maken geen deel uit van deze bouwset):

Art. Nr. 170490 | 170492 | 170494  
FALLER SUPER-EXPERT | EXPERT | LASERCUT



Art. Nr. 170688  
SPEZIAL-SEITENSCHNEIDER



Art. Nr. 170687  
FALLER-BASTELMESSER



<b>Inhalt</b>	Spritzlinge	1 A 1 x	3 3 x	7 A 1 x	TR 9 1 x
<b>Contents</b>	Sprues	1 B 1 x	4 1 x	7 B 1 x	
<b>Contenu</b>	Moulages	2 1 x	6 1 x	8 1 x	
<b>Inhoud</b>	Gietstukken				

Sa. Nr. 140 336 1

2

6/2

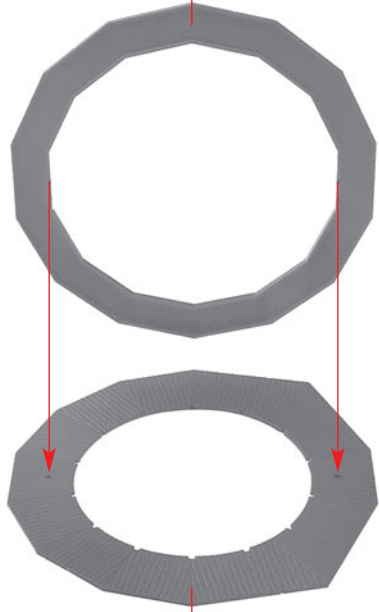

**A**

6/1

2/1

2/2

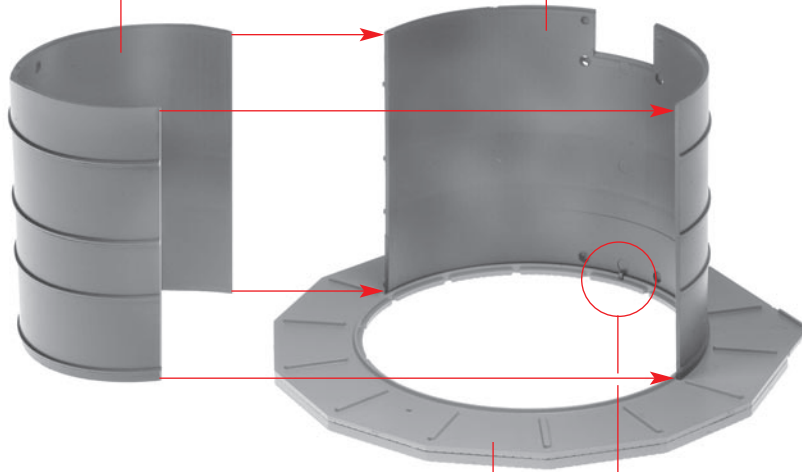

**B**

**A**

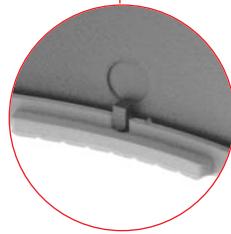

2/3

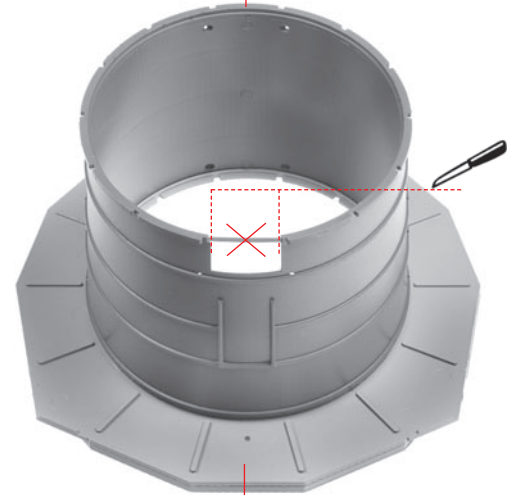

**C**

**B**

3/2

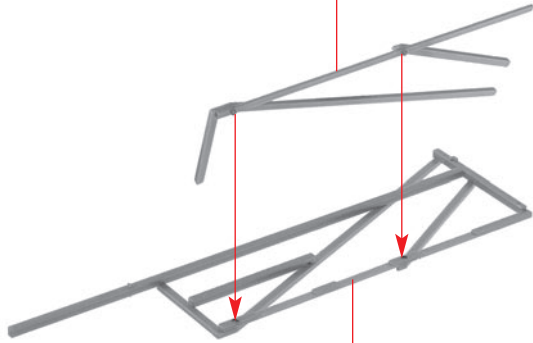

**D** 14 x

3/1

14 x **D**

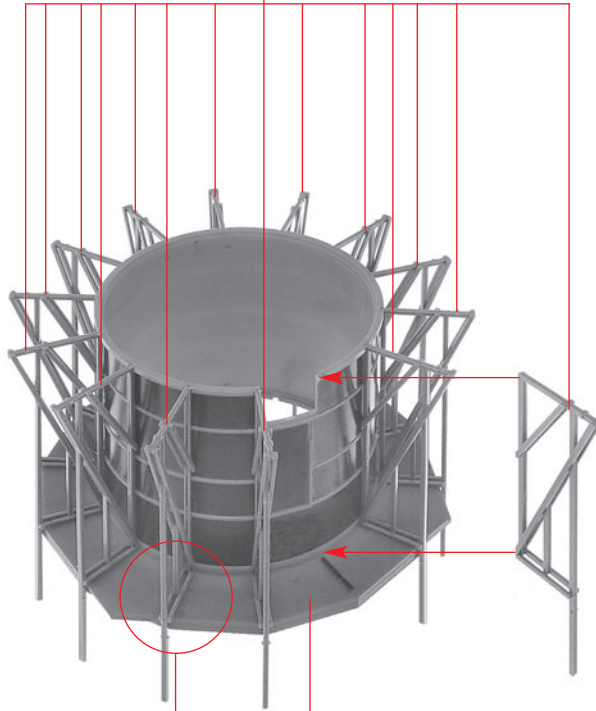

**E**

**C**



13 x 3/3

**3**

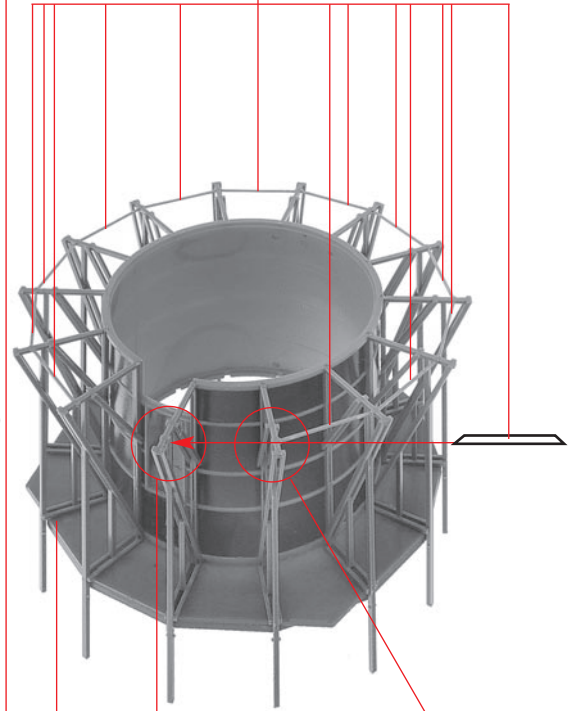

**E**  
**F**



4

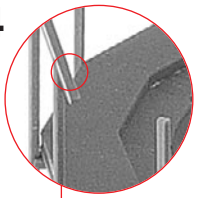

6/13

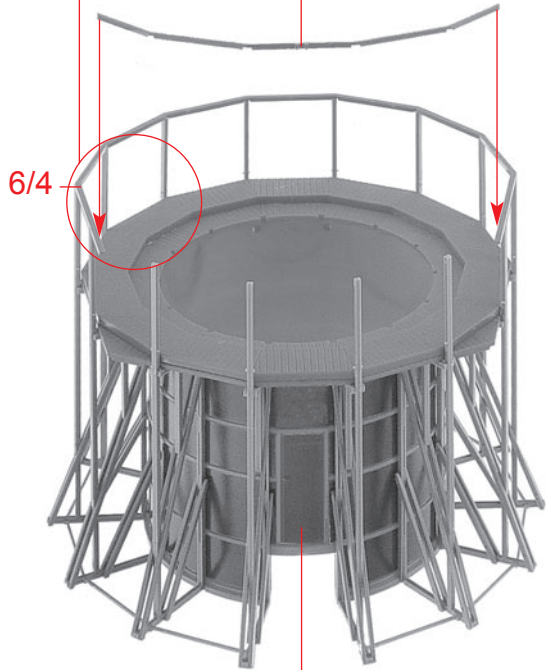

6/4

**G**

**F**

4/5

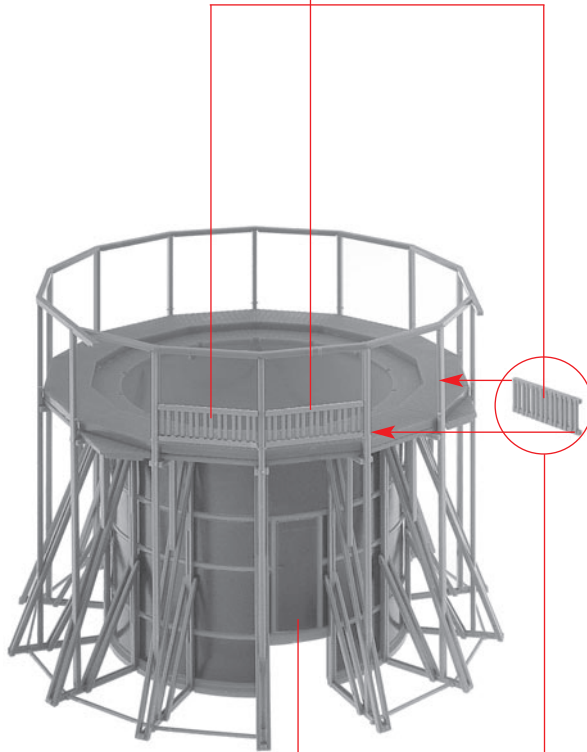

**H**

**G**

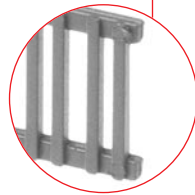

9 x 4/5

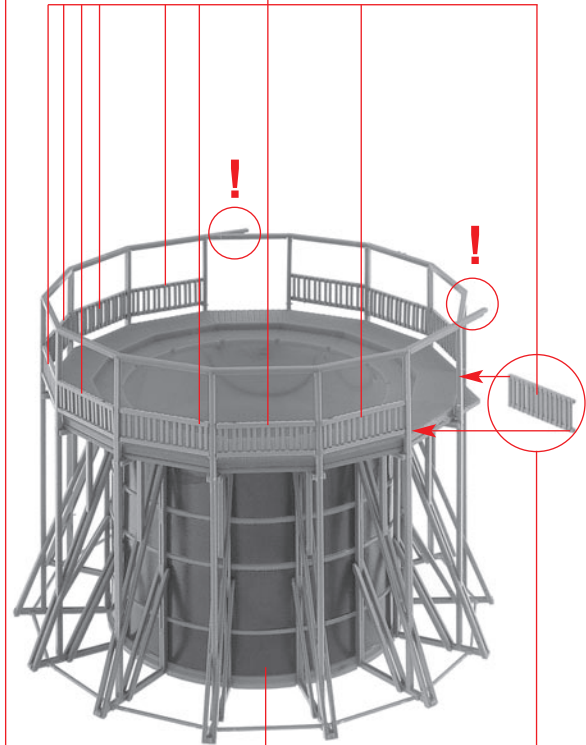

**I**

**H**

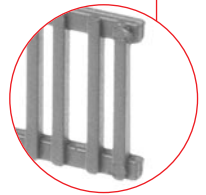

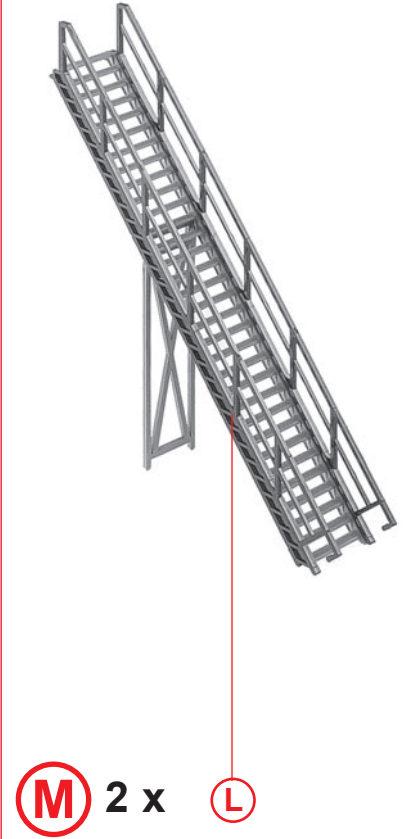
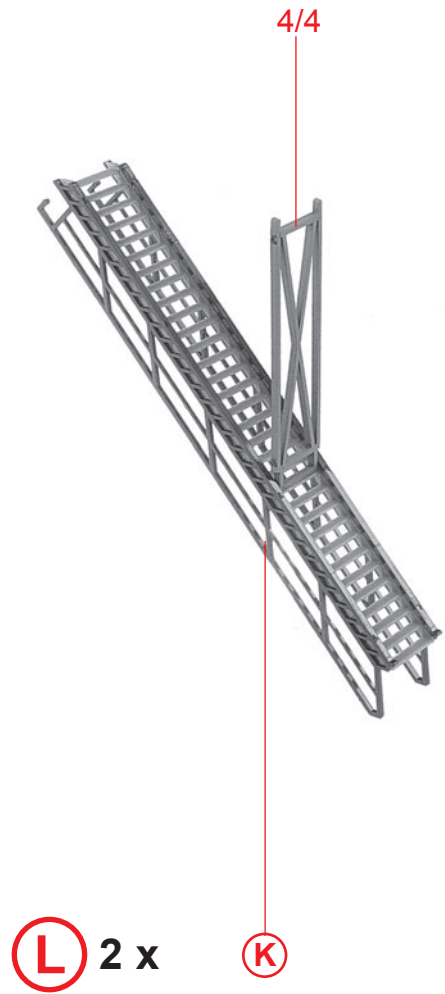
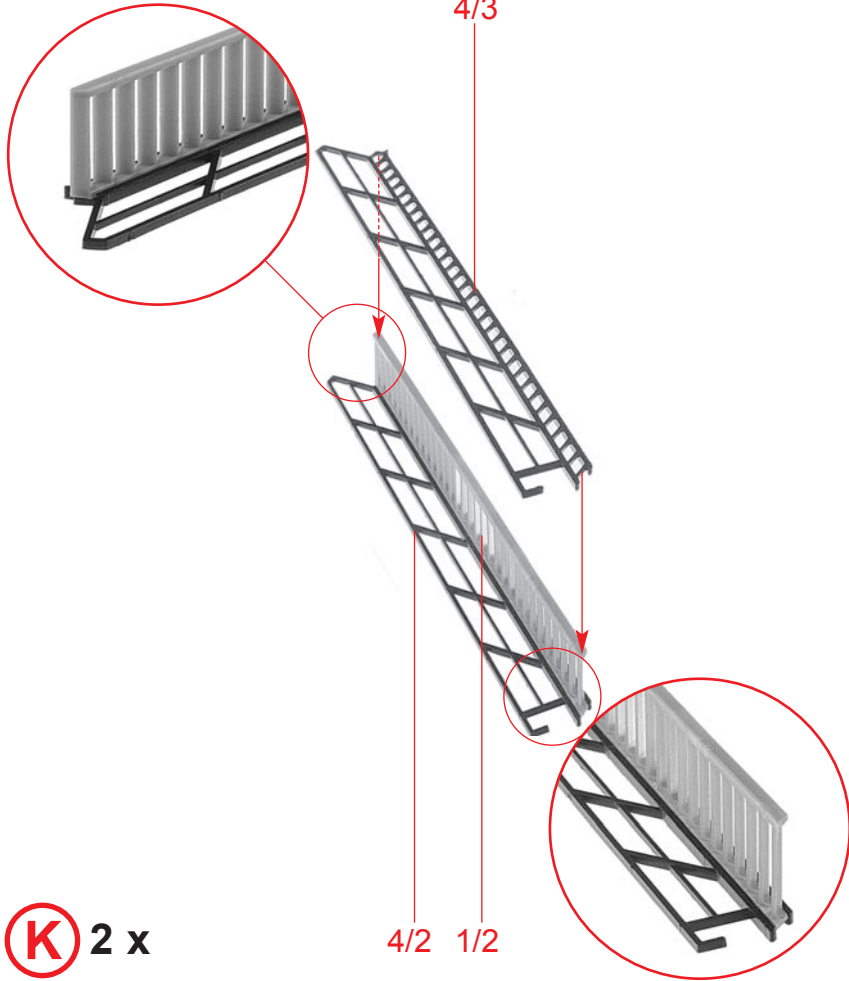

6

4/6

J

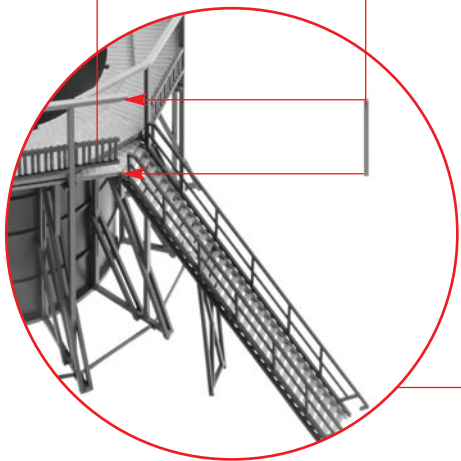

J

4/6

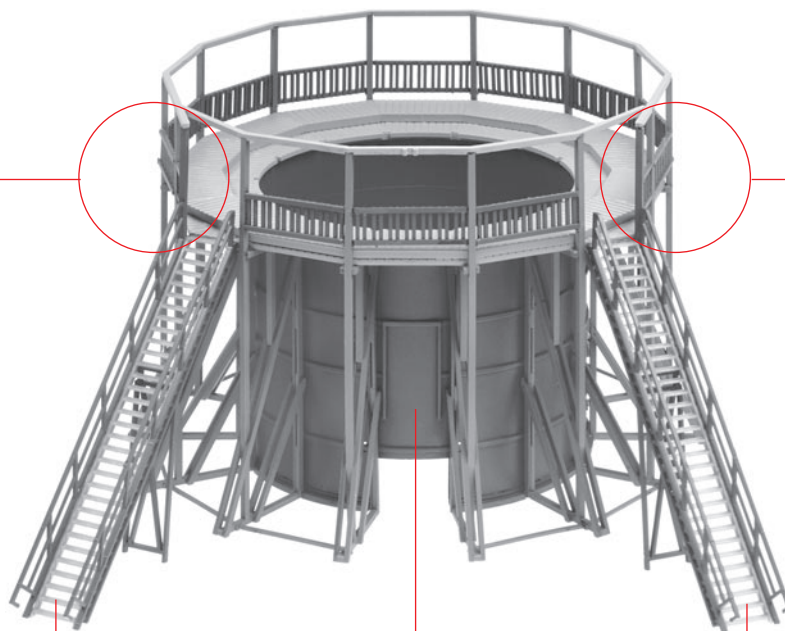
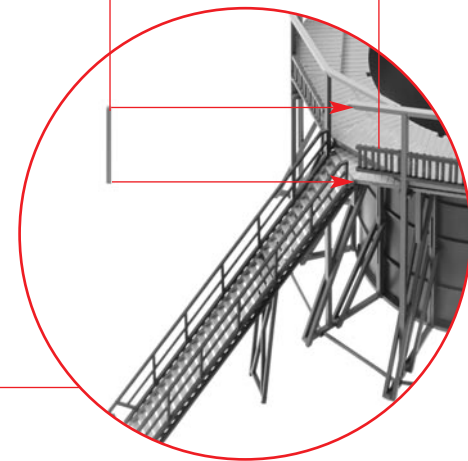

N

M

I

M

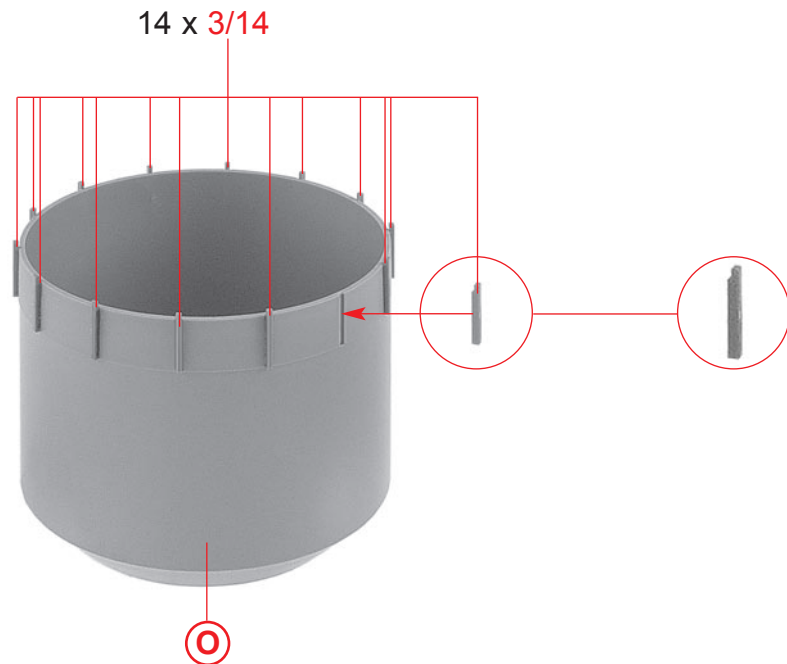

Inhalt	Tüte 2	Contents	bag 2
Contenu	sachet 2	Inhoud	zakje 2

nicht kleben  
do not glue  
ne pas coller  
niet lijmen

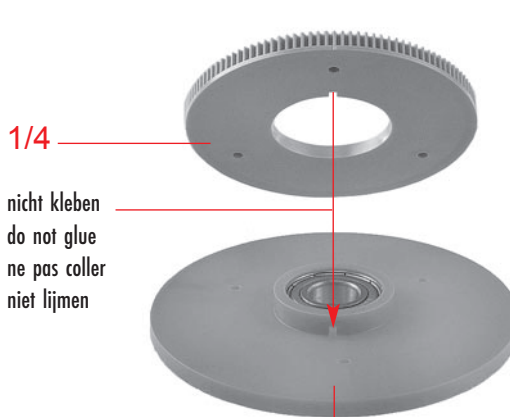

Inhalt	Tüte 2	Contents	bag 2
Contenu	sachet 2	Inhoud	zakje 2

kurz  
short  
court  
koort

nicht kleben  
do not glue  
ne pas coller  
niet lijmen

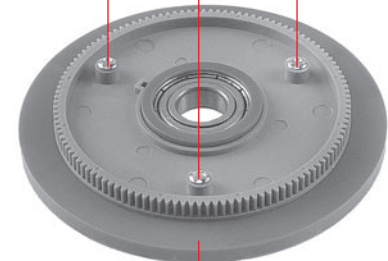

**Q**

**Q**

**S**

**R**

8

<b>Inhalt</b>	Tüte 2	<b>Contents</b>	bag 2
<b>Contenu</b>	sachet 2	<b>Inhoud</b>	zakje 2

nicht kleben  
do not glue  
ne pas coller  
niet lijmen

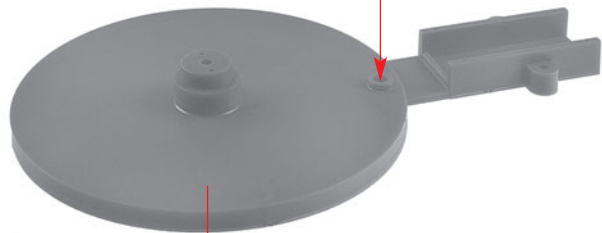

2/4

T

<b>Inhalt</b>	Tüte 2	<b>Contents</b>	bag 2
<b>Contenu</b>	sachet 2	<b>Inhoud</b>	zakje 2

nicht kleben  
do not glue  
ne pas coller  
niet lijmen

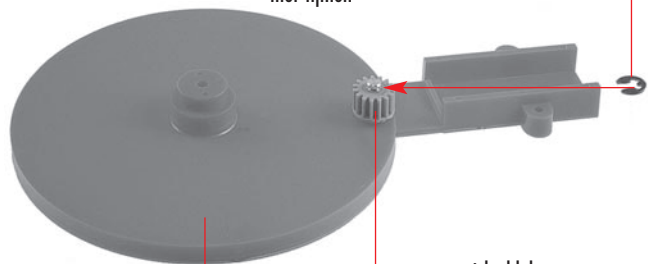

1/5

nicht kleben  
do not glue  
ne pas coller  
niet lijmen

T

U

P



nicht kleben  
do not glue  
ne pas coller  
niet lijmen

S

nicht kleben  
do not glue  
ne pas coller  
niet lijmen



V

U

V



nicht kleben  
do not glue  
ne pas coller  
niet lijmen  
kurz  
short  
court  
koort

2,2 x 6,5 mm

W

<b>Inhalt</b>	Tüte 2	<b>Contents</b>	bag 2
<b>Contenu</b>	sachet 2	<b>Inhoud</b>	zakje 2



Die Magnete zusammenspringen lassen. Jeden einzelnen der aneinanderhaftenden Magnete gut sichtbar auf einer Seite mit einem Farbpunkt, Filzschreiber oder ähnlichem markieren (auf Polung achten).

Have the magnets cling together. Mark each of the magnets adhering to each other well visible on one side with a colour dot, felt pen or the like (see to it that poling is correct).

Laisser s'accoler les aimants. Marquer chaque aimant accolé de façon bien visible d'un côté avec un point coloré, un feutre de couleur ou similaire (veiller à respecter la polarité).

Laat de magneten tegen elkaar springen. Merk elke magneet goed zichtbaar en steeds aan dezelfde platte kant met verf, viltstift of dergelijke (let op de juiste polariteit).

**X** 2 x

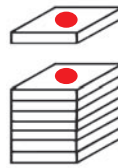

**Inhalt** Plexiglasbehälter  
**Contents** Plexiglas container  
**Contenu** Récipient en plexiglas  
**Inhoud** Plexiglasreservoir

Sekundenkleber verwenden.  
 Use instant modelling cement.  
 Utilisez la colle rapide.  
 Gebruik secondenlijm.

**Inhalt** Tüte 2  
**Contents** bag 2  
**Contenu** sachet 2  
**Inhoud** zakje 2



2/7

**Y** **X**

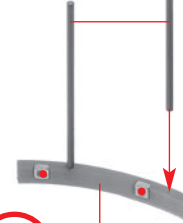

**Z** **X**



9

170488

**Y**

**Z**

170488

Art. Nr. 170488  
 Spezialschmiermittel, liegt nicht bei  
 Special lubricant, not included  
 Lubrifiant special, non jointe  
 Speciaal smeermiddel, niet bijgevoegd

Sekundenkleber verwenden.  
 Use instant modelling cement.  
 Utilisez la colle rapide.  
 Gebruik secondenlijm.

Spezialschmiermittel  
 Special lubricant  
 Lubrifiant special  
 Speciaal smeermiddel

**Inhalt** Plexiglasbehälter  
**Contents** Plexiglas container  
**Contenu** Récipient en plexiglas  
**Inhoud** Plexiglasreservoir

2/6

2,2 x 19 mm

**Inhalt** Tüte 2  
**Contents** bag 2  
**Contenu** sachet 2  
**Inhoud** zakje 2

Sekundenkleber verwenden.  
 Use instant modelling cement.  
 Utilisez la colle rapide.  
 Gebruik secondenlijm.

Motor, nicht kleben  
 Motor, do not glue  
 Moteur, ne pas coller  
 Motor, niet lijmen

**Inhalt** Tüte 2  
**Contents** bag 2  
**Contenu** sachet 2  
**Inhoud** zakje 2

5 V DC



**a**

**w**

10

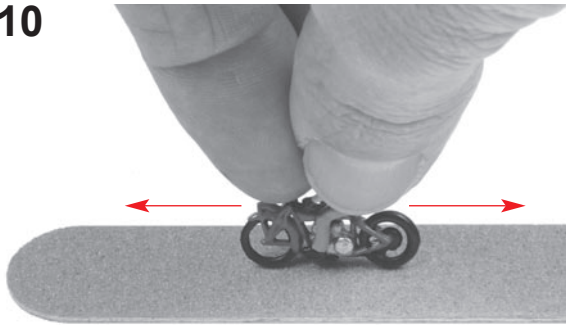

Klebestelle anrauen !  
 Roughen area to be glued !  
 Poncer l'emplacement du collage !  
 Lijmplaats opruwen !

**b**

Magnete  
 Magnets  
 Aimants  
 Magneet

Grat entfernen!  
 Deburr!  
 Enlever les bavures!  
 Graat verwijderen!

Sekundenkleber verwenden.  
 Use instant modelling cement.  
 Utilisez la colle rapide.  
 Gebruik secondenlijm.

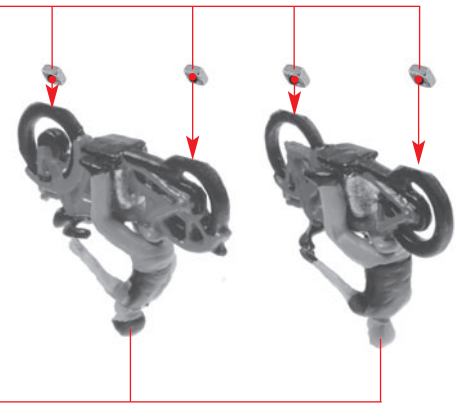

<b>Inhalt</b>	Plexiglasbehälter	<b>Contents</b>	Plexiglas container
<b>Contenu</b>	Réceptien en plexiglas	<b>Inhoud</b>	Plexglasreservoir

6/3

Art. Nr. 170488

Spezialschmiermittel, liegt nicht bei  
 Special lubricant, not included  
 Lubrifiant special, non jointe  
 Speciaal smeermiddel, niet bijgevoegd

**b**

**a**

**c**

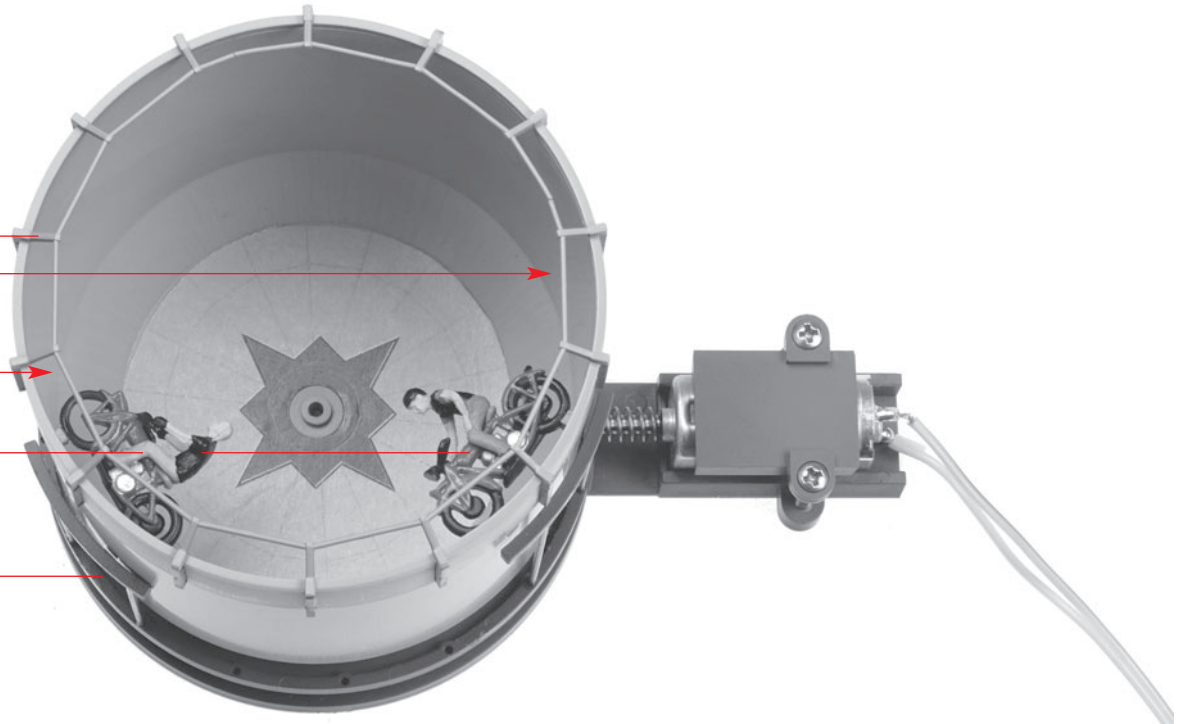

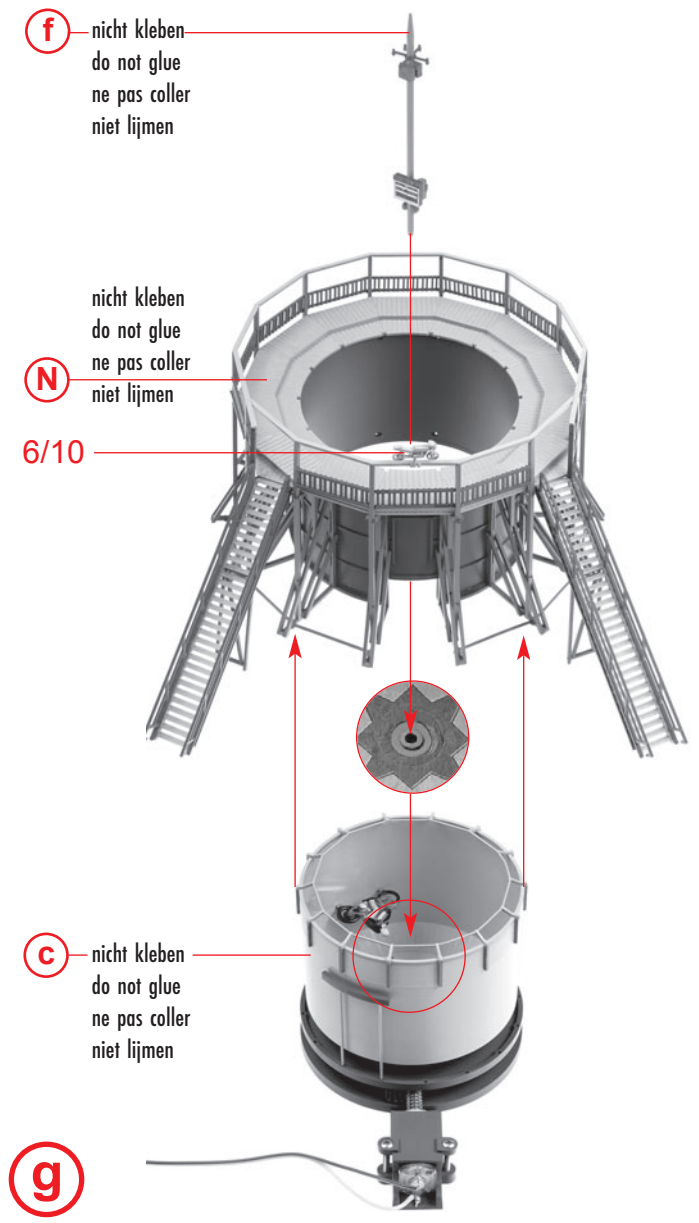
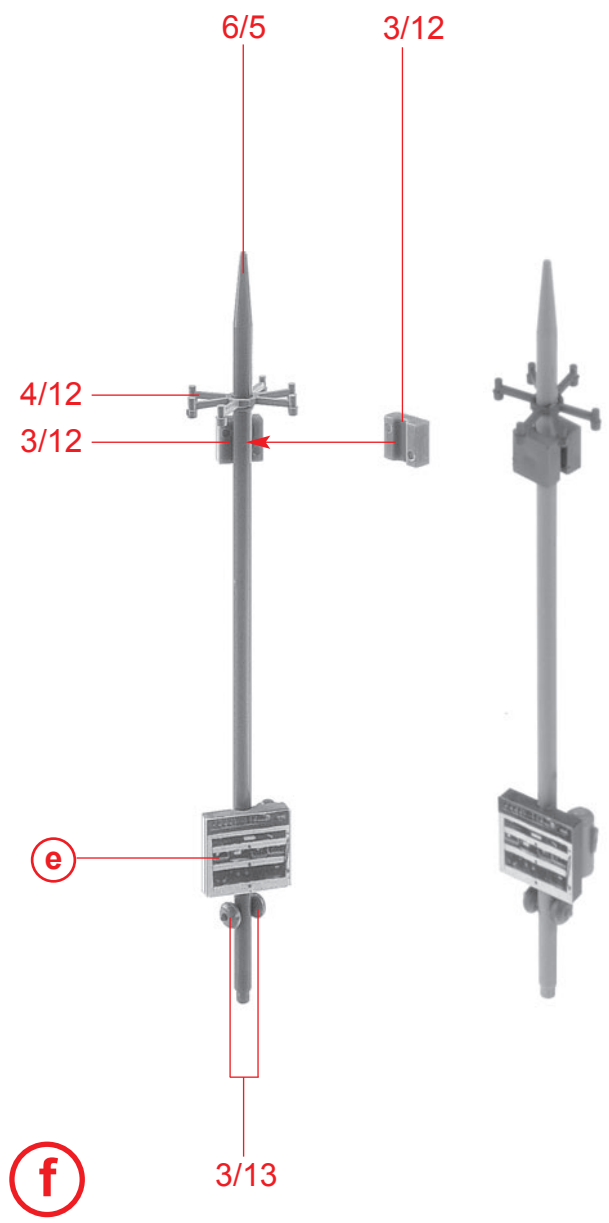
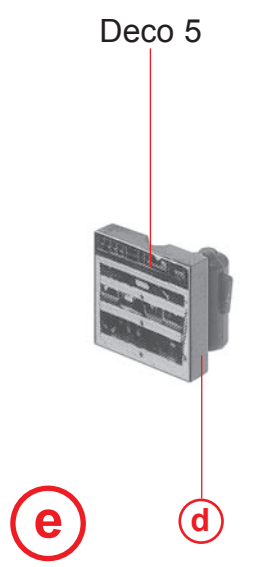
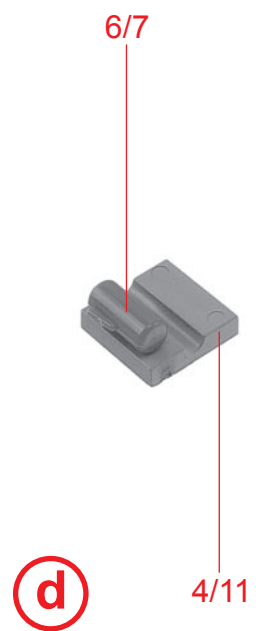

12



**h** 2 x 3/11

**i**

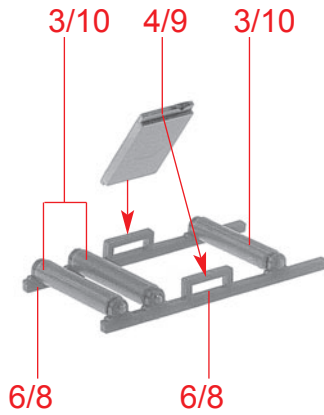

**j**

**i**

**k**

Deco 2

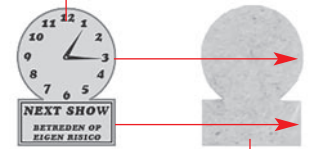

Mit Alleskleber kleben.  
Use all-purpose glue.  
Utiliser de la colle universelle.  
Met een universele lijm lijmen.

9/2

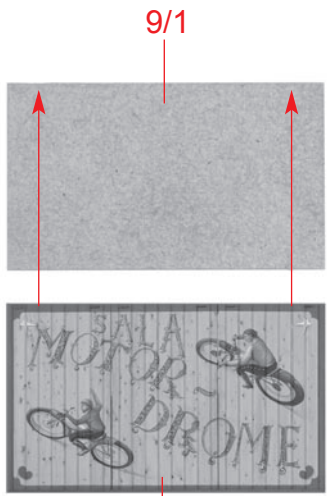

**l** Deco 1

**m**

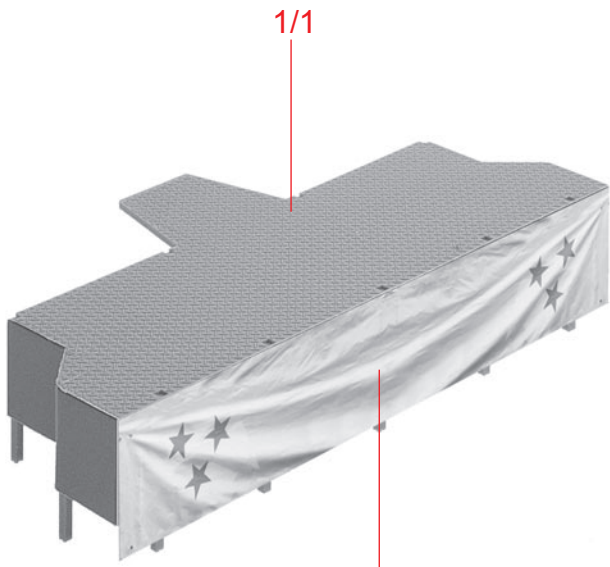

Deco 4

**n**

**j**

**h**

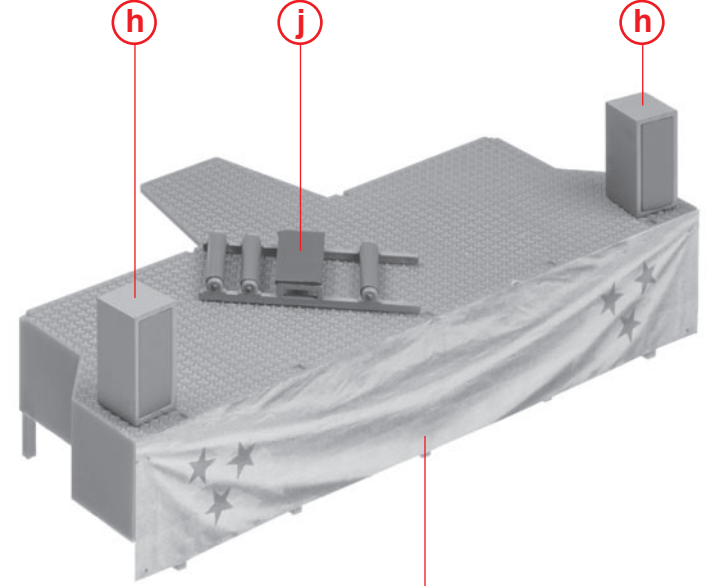

**m**

Mit Alleskleber kleben.  
Use all-purpose glue.  
Utiliser de la colle universelle.  
Met een universele lijm lijmen.

nicht kleben  
do not glue  
ne pas coller  
niet lijmen

7/1

Deco 6



Mit Alleskleber kleben.  
Use all-purpose glue.  
Utiliser de la colle universelle.  
Met een universele lijm lijmen.

I

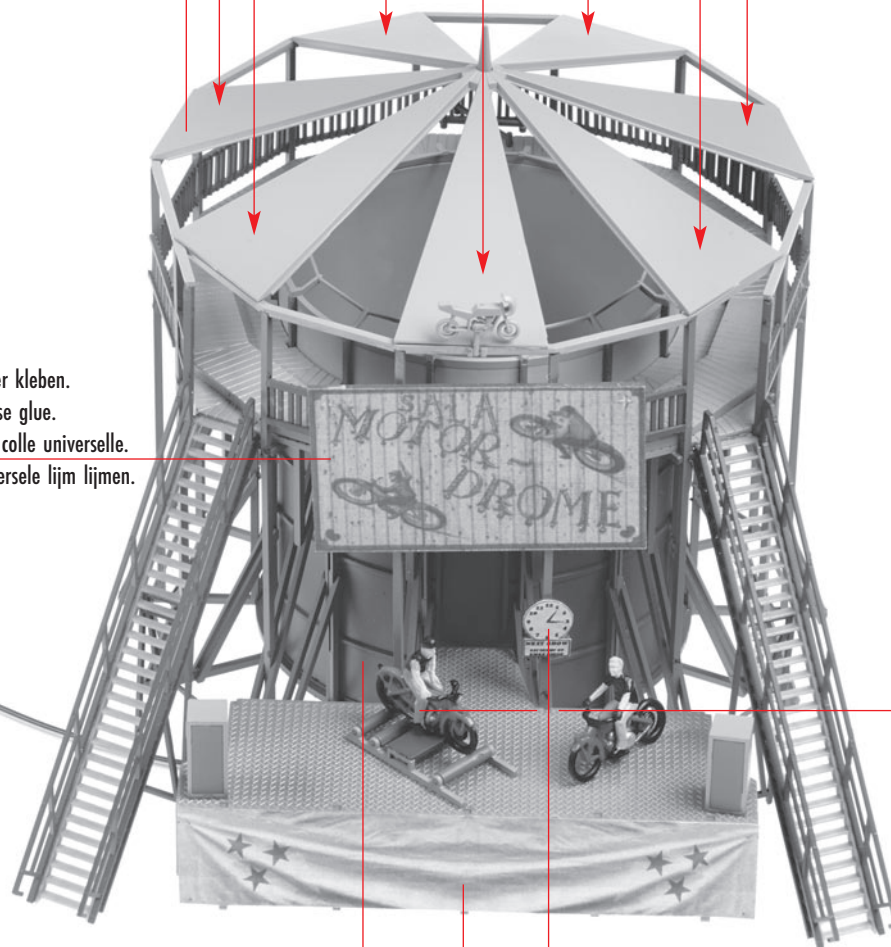

<b>Inhalt</b>	Plexiglasbehälter
<b>Contents</b>	Plexiglas container
<b>Contenu</b>	Réceptien en plexiglas
<b>Inhoud</b>	Plexiglasreservoir

Mit Alleskleber kleben.  
Use all-purpose glue.  
Utiliser de la colle universelle.  
Met een universele lijm lijmen.

g

n

k





Variante

7/2

7/1

7/2

q

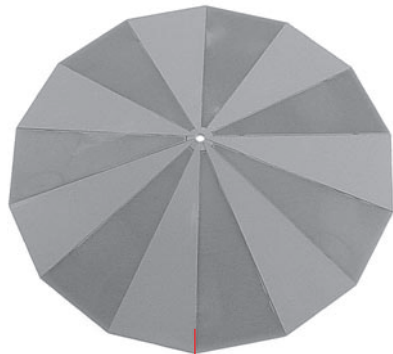
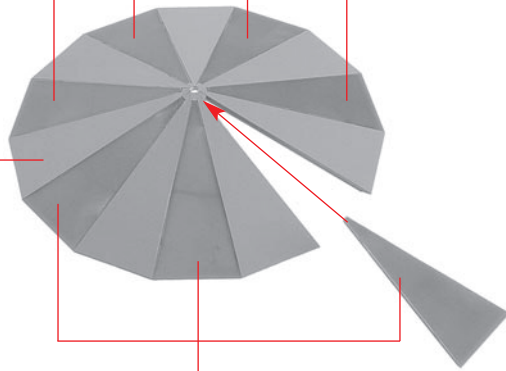

r

q

15

Deco 6

r

nicht kleben  
do not glue  
ne pas coller  
niet lijmen

l

s

g

n

k

