

# BAHNHOF »SCHWARZBURG«



»SCHWARZBURG« STATION

GARE DE »SCHWARZBURG«

STATION »SCHWARZBURG«

Art. Nr. 212111

**D**

Machen Sie sich bitte vor Beginn des Bastelns mit dem Bausatzinhalt und der Anleitung vertraut und prüfen Sie die Vollständigkeit. Im Reklamationsfall gilt die gesetzliche Gewährleistungspflicht. Sollte ein Teil fehlen, übersenden Sie bitte den Teilwunsch und den Kaufbeleg an: Gebr. FALLER GmbH, Kundendienst, Kreuzstraße 9, D-78148 Gütenbach, kundendienst@faller.de. Sollten Sie einmal weitere Ersatzteile benötigen, senden wir Ihnen den benötigten Spritzling, bei Verfügbarkeit, gerne kostenpflichtig zu. Bitte beachten Sie, dass produktionsbedingt Einzelteile übrig bleiben können.

**GB**

Before building your model, please familiarize yourself with the contents of the kit and the instructions for use, also checking whether the set of parts is complete. In case of any complaint, the legal guarantee obligation shall apply. Should a part be missing, please send the designation of the part required and the receipt documenting your purchase to: Gebr. FALLER GmbH, Kundendienst, Kreuzstraße 9, D-78148 Gütenbach, kundendienst@faller.de. Should you require further spare parts one day, we shall be pleased to send you, with costs, the required sprue, if it is available. Please note that, on grounds of the production process, some single injection molded parts may be superfluous.

**F**

Avant de commencer votre modèle, veuillez vous familiariser avec le contenu du kit et la notice d'emploi, et contrôlez que le lot de pièces est complet. En cas de réclamation, il s'appliquera l'obligation de garantie légale. Au cas où une pièce manquerait, veuillez envoyer la désignation de la pièce souhaitée et le bon d'achat à: Gebr. FALLER GmbH, Kundendienst, Kreuzstraße 9, D-78148 Gütenbach, kundendienst@faller.de. Au cas où vous auriez besoin un jour d'autres pièces détachées, nous vous enverrons volontiers la grappe requise, si elle est disponible, contre paiement. Veuillez noter que, pour des raisons de production, il se peut que des pièces détachées soient superflues.

**NL**

Maak uzelf vóór het bouwen vertrouwd met de inhoud van het bouwpakket en met de handleiding en controleer de volledigheid. In geval van reclamatie geldt de wettelijke garantieverplichting. Mocht er een onderdeel ontbreken, stuur het verzoek om het gewenste onderdeel en het aankoopbewijs dan naar: Gebr. FALLER GmbH, klantenservice, Kreuzstraße 9, D-78148 Gütenbach, kundendienst@faller.de. Als u ooit meer reserveonderdelen nodig hebt, sturen wij het benodigde gietstuk, indien beschikbaar, graag tegen betaling naar u op. Let op: om productieredenen kunnen losse onderdelen overblijven.

Für den Zusammenbau des Modells empfehlen wir folgende FALLER-Artikel (sind nicht im Bausatz enthalten):

For the assembly of the kit we recommend following FALLER products (not included in the kit):

Pour l'assemblage du modèle, nous vous recommandons les articles FALLER suivants (non inclus dans le kit):

Om dit model te bouwen adviseren wij de volgende FALLER producten (maken geen deel uit van deze bouwset):

Art. Nr. 170490 | 170492 | 170494  
FALLER SUPER-EXPERT | EXPERT | LASERCUT



Art. Nr. 170688  
SPEZIAL-SEITENSCHNEIDER



Art. Nr. 170687  
FALLER-BASTELMESSER



<b>Inhalt</b>	Spritzlinge	1	1 x	4	1 x	7	1 x	10	1 x	3	1 x
<b>Contents</b>	Sprues	2	1 x	5	1 x	8	1 x	11	1 x		
<b>Contenu</b>	Moulages	3	1 x	6	1 x	9	1 x	12	1 x		
<b>Inhoud</b>	Gietstukken										

Sa. Nr. 219 381 0

## 2 Fensterfolie

Das abgebildete Papier-Musterfenster mit transparentem Klebeband auf die beiliegende Fensterfolie kleben und diese ausschneiden. Fensterfolie vorsichtig mit wenig Klebstoff auf die Rückseite der Fensterrahmen aufkleben.

### Window plastic sheet

Using clear adhesive tape fix the pattern window made of paper pictured to the window plastic sheet supplied, and cut that sheet out. Using very little glue, cautiously stick the window sheet to the back of the window frame.

### Feuille transparente pour fenêtres

À l'aide de ruban adhésif transparent coller la fenêtre à dessin en papier représentée sur la feuille transparente fournie, et découper cette feuille. Coller avec précaution la feuille transparente, avec très peu de colle, au dos du cadre de la fenêtre.

### Raamfolie

De afgebeelde papieren raamdecoratie met transparant plakband op de meegeleverde raamfolie plakken en uitknippen. Raamfolie voorzichtig met een beetje lijm op de achterzijde van de ramen lijmen.

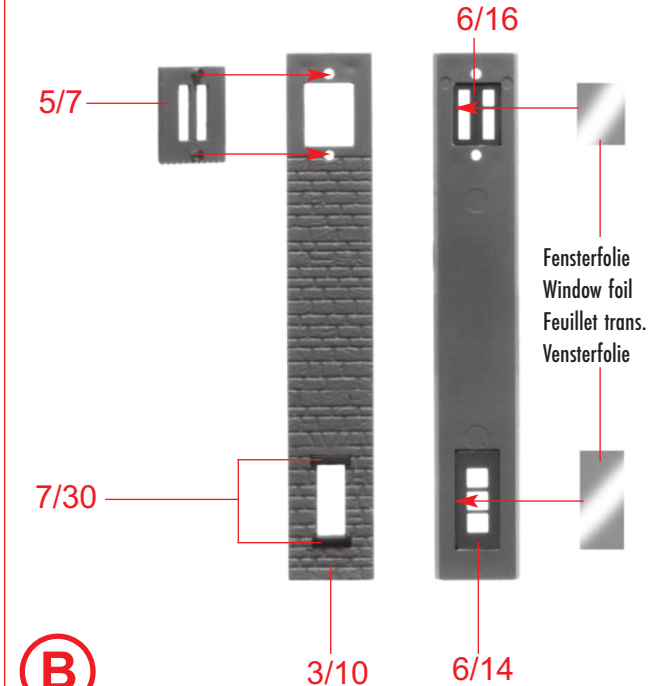
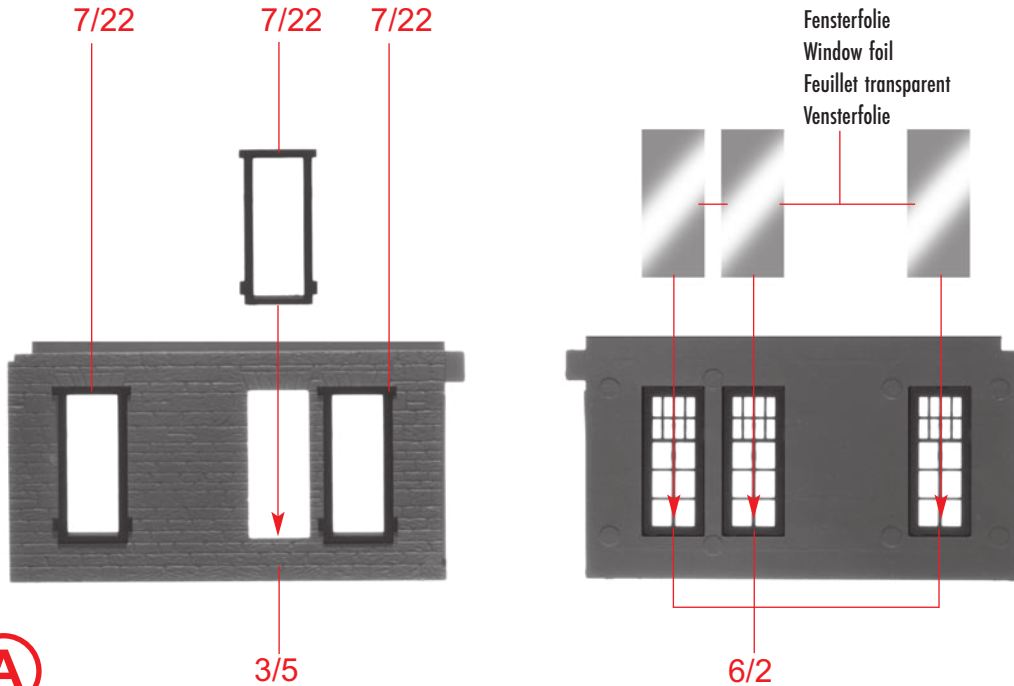
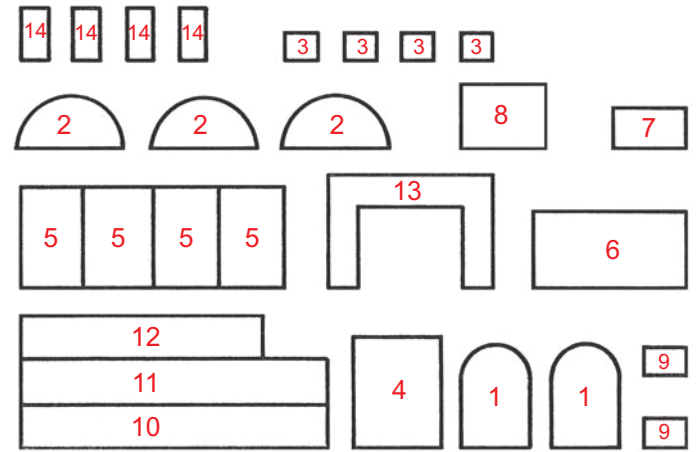

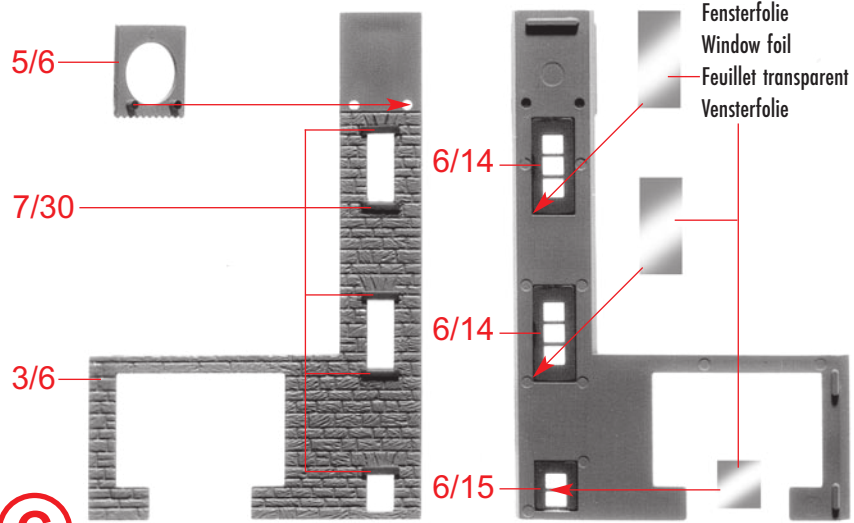

**C**

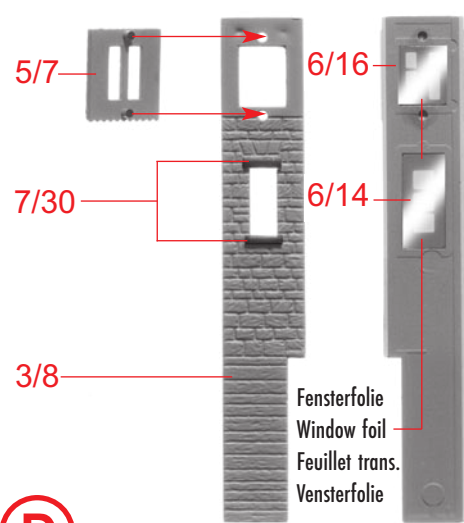

**D**

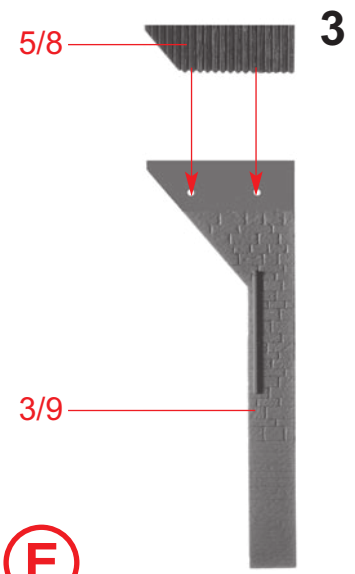

**E**

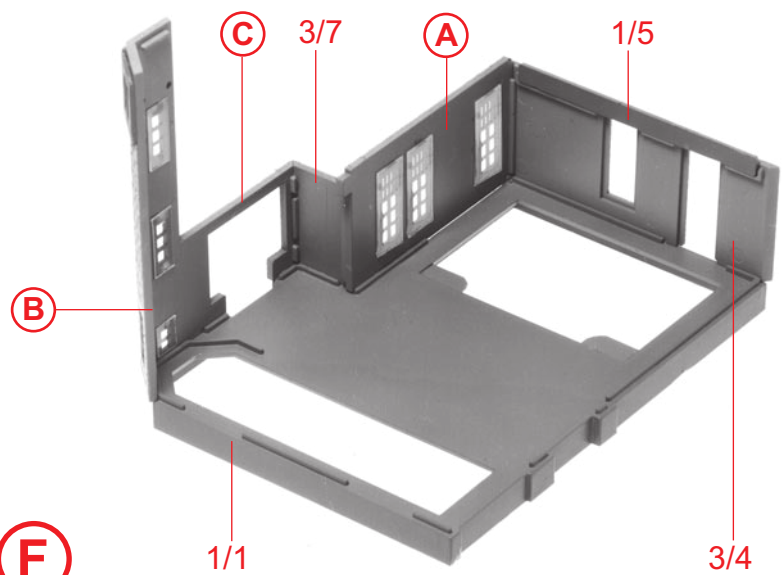

**F**

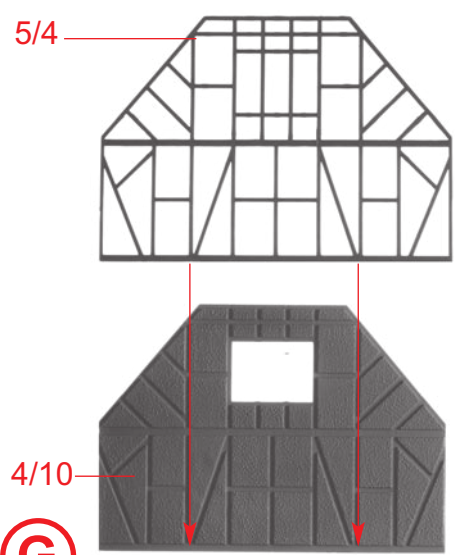

**G**

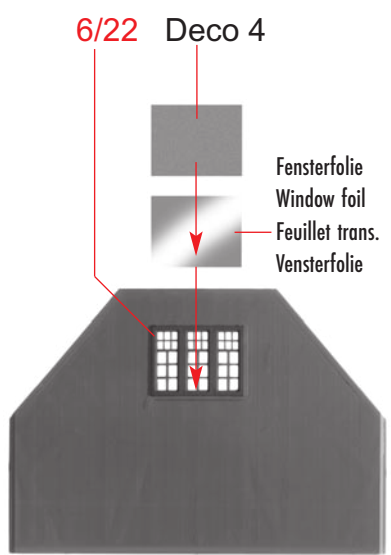

**3**

4

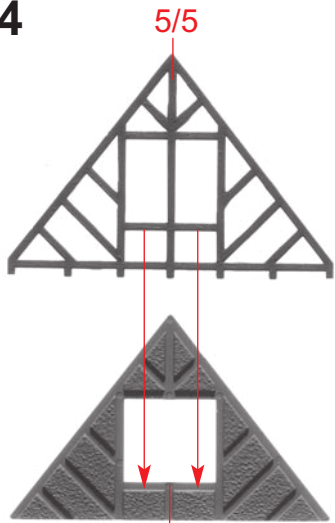

4/12

Deco 3

Fensterfolie  
Window foil  
Feuillet trans.  
Vensterfolie

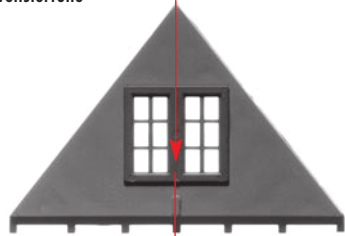

6/11

H

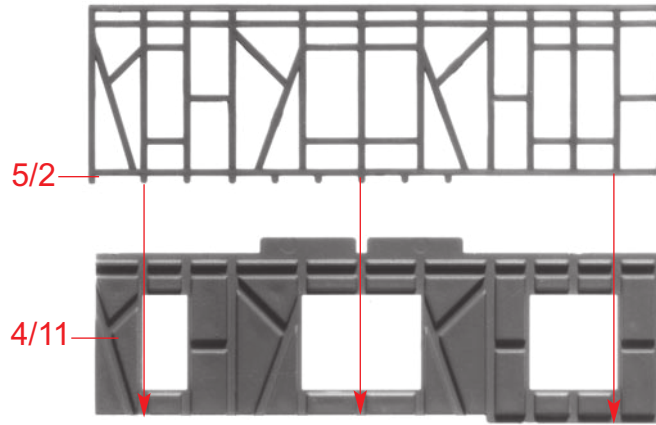

I

5/9

7/31

7/32

7/34

7/33

J

3/11

Fensterfolie  
Window foil  
Feuillet trans.  
Vensterfolie

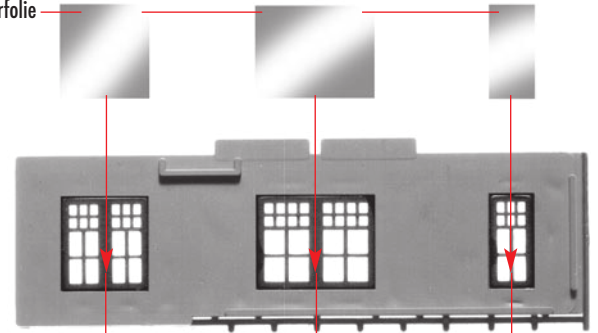

6/6

6/10

6/8

Deco 1

Deco 2

6/18

6/19

6/21

6/17

Fensterfolie  
Window foil  
Feuillet trans.  
Vensterfolie

6/20

5/11

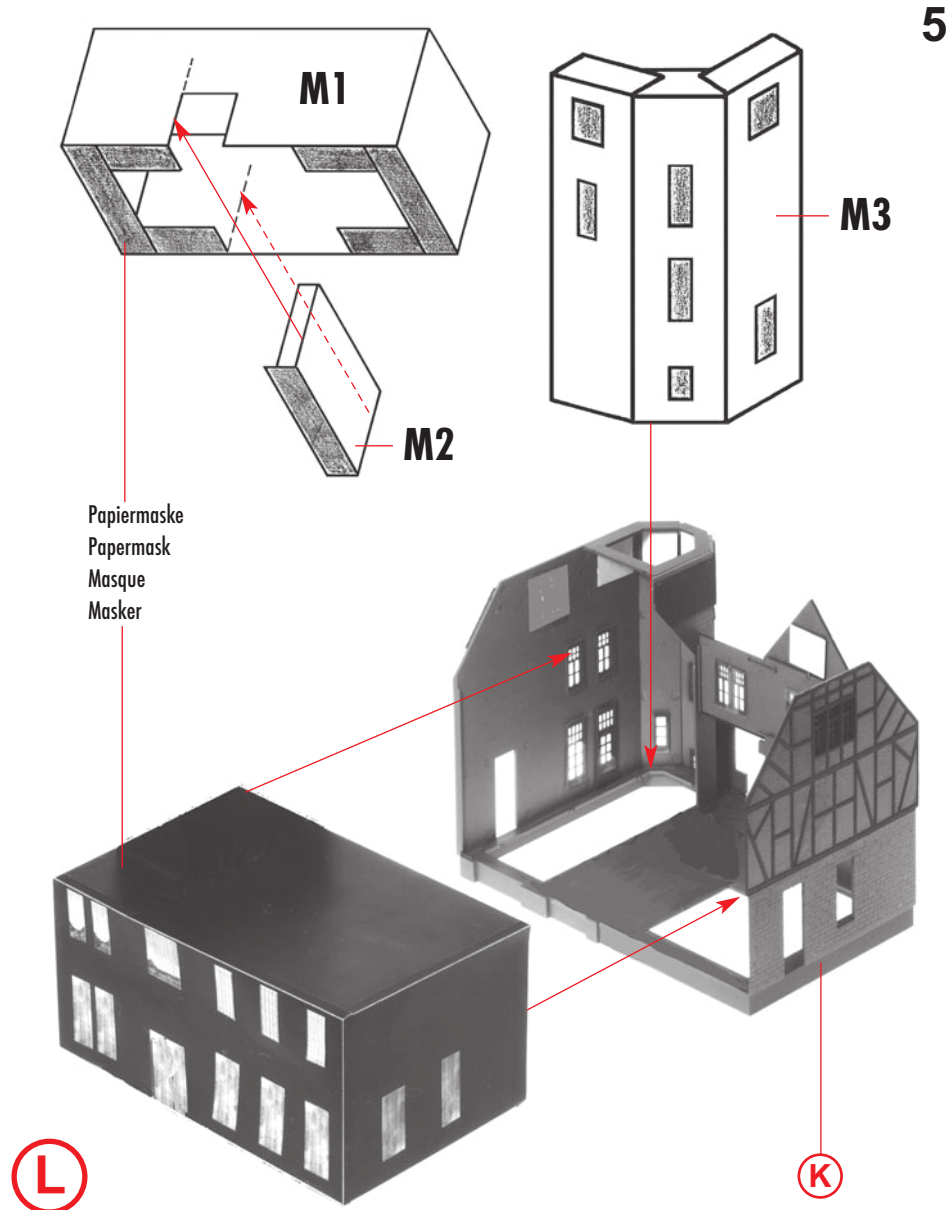
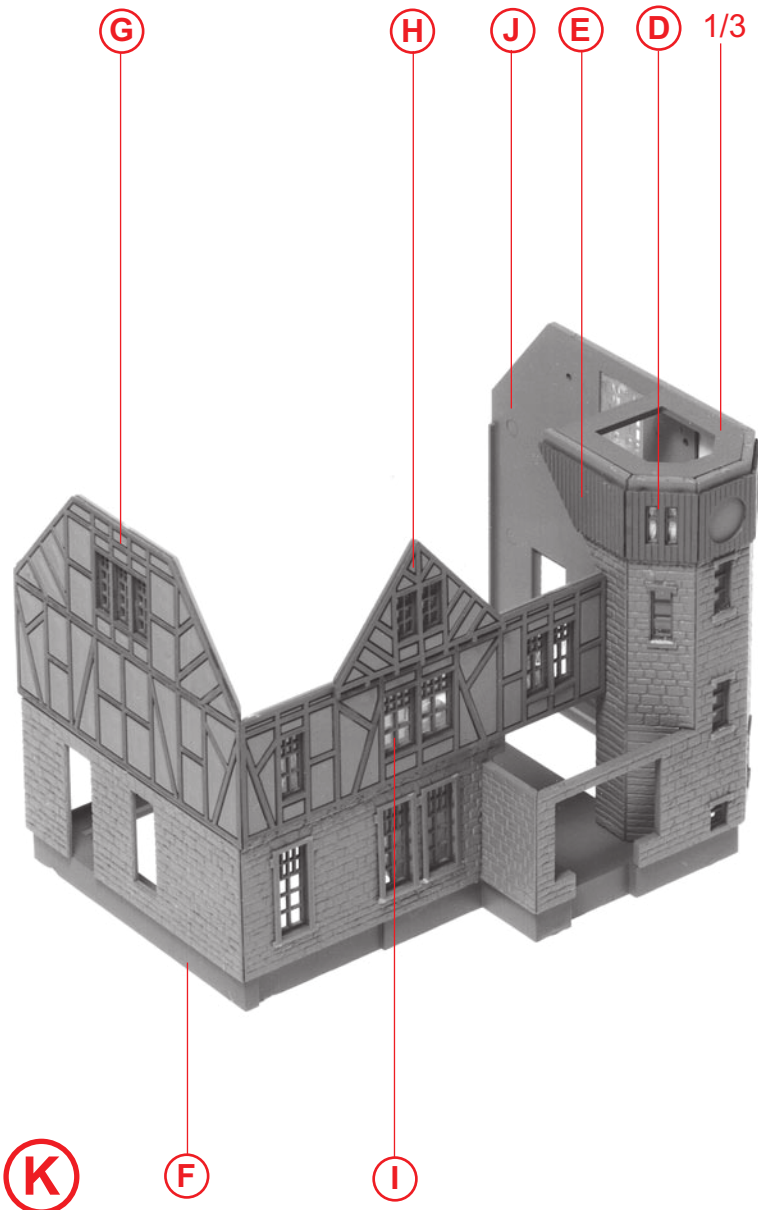



6



3/3 7/23

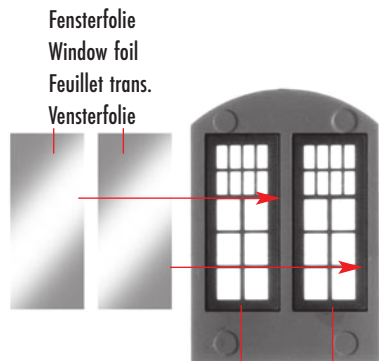

6/2

M

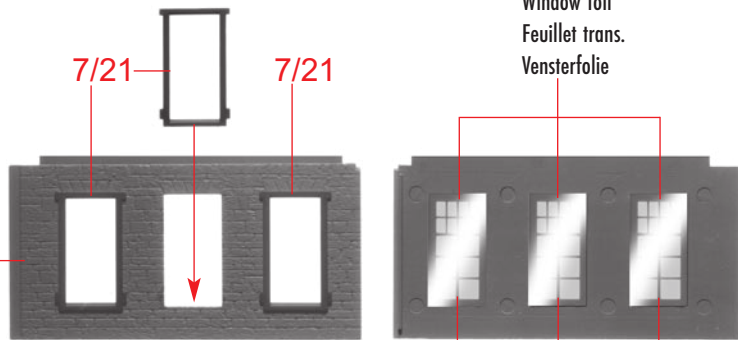

3/2

6/1

N

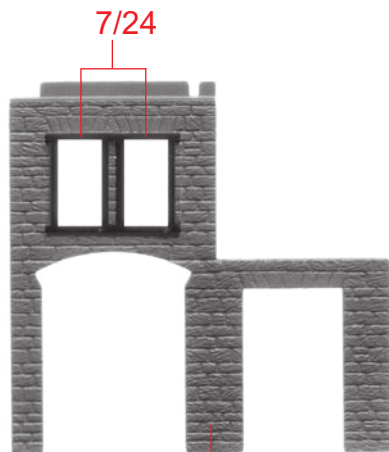

7/24

3/1

O

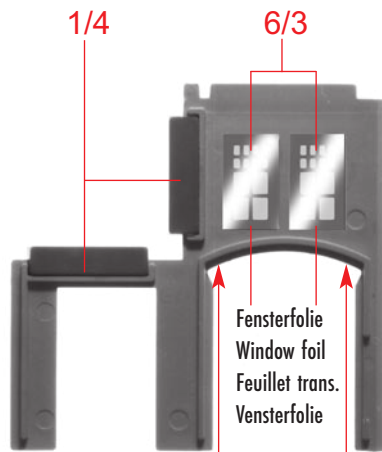

1/4

6/3

Fensterfolie  
Window foil  
Feuillet trans.  
Vensterfolie

M



5/1



4/8

6/5

Fensterfolie  
Window foil  
Feuillet trans.  
Vensterfolie

6/6

P

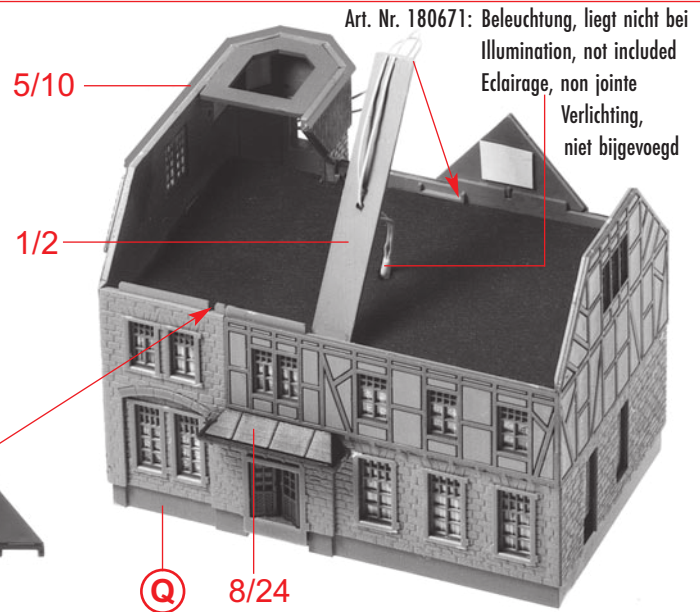
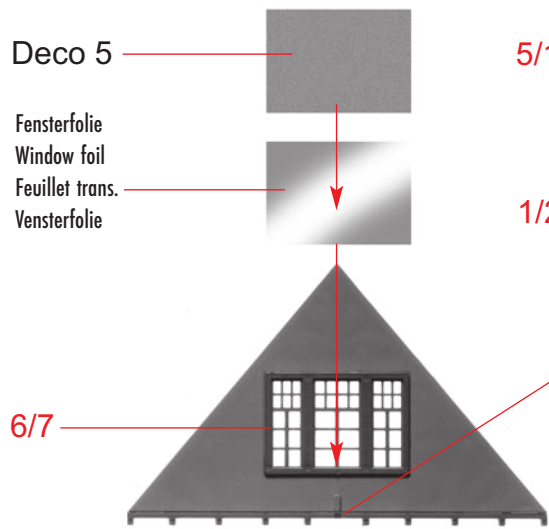
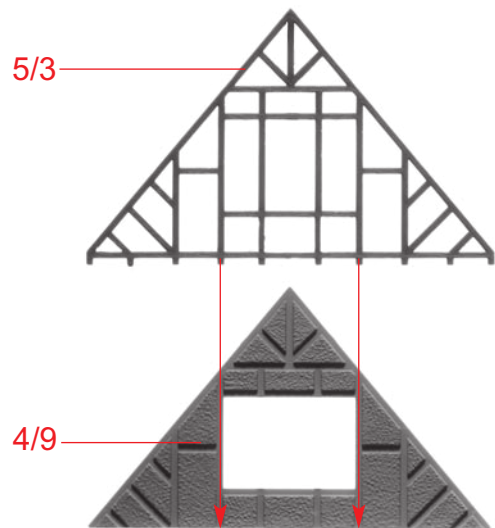
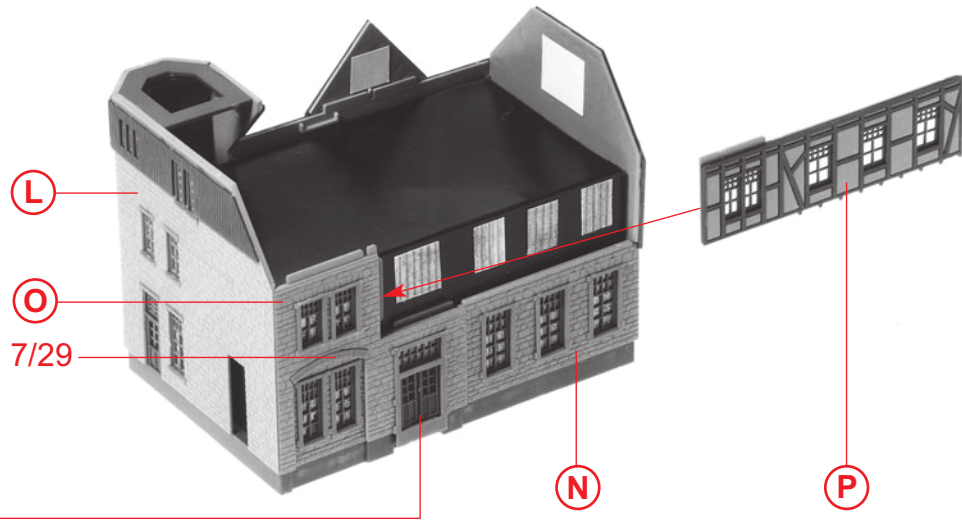
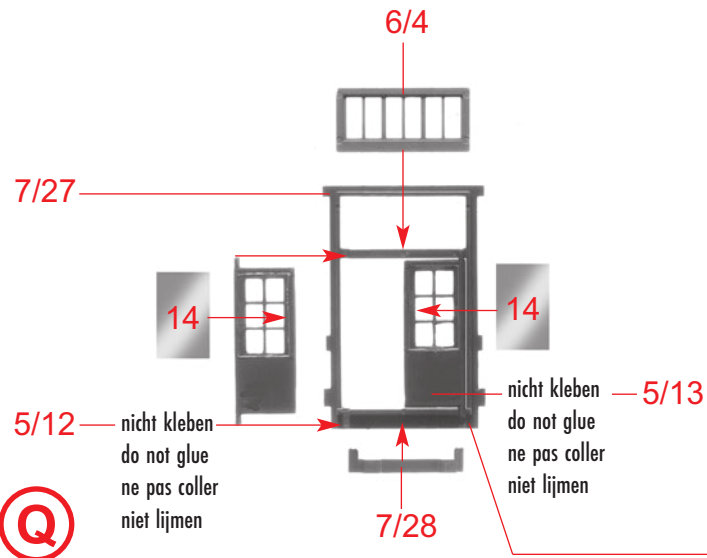

Q

R

8

Deco 7

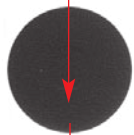

S

7/53

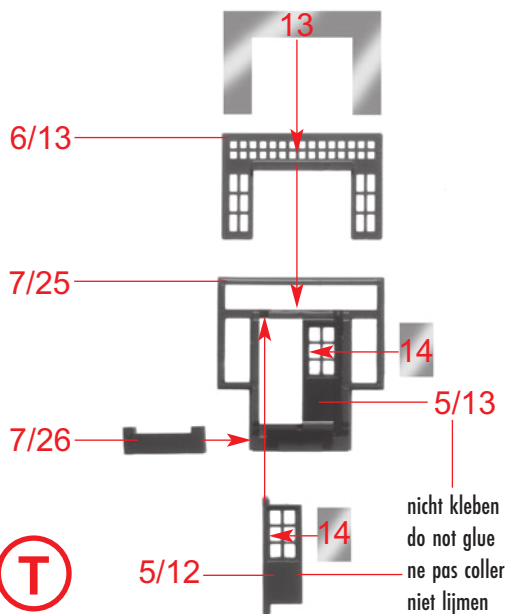

T

5/12

nicht kleben  
do not glue  
ne pas coller  
niet lijmen

U

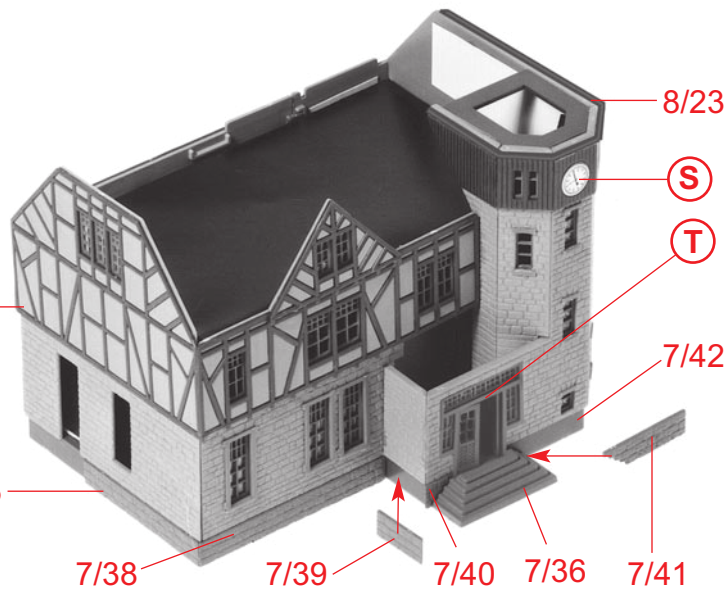

Die Dachziegel können mit handelsüblichen gelben und braunen Farbstiften (liegen nicht bei) zur feineren Gestaltung bemalt werden. Die zu colorierenden Ziegel sind optisch durch eine Hochglanzpolierung sichtbar. Drehen Sie die Dachteile im Licht leicht hin und her, bis das Muster erscheint. Beginnen Sie das Bemalen, der Skizze entsprechend, mit der braunen Farbe, danach mit dem gelben Stift. Am leichtesten geht das Bemalen am unmontierten Spritzteil. Die Turmsegmente werden nur mit Gelb bemalt.

It is possible to colour the roof tiles using commercially available yellow and brown pencils (not supplied) to create a more appealing design. The tiles to be coloured are visible by their high mirror polish. Turn the roof parts exposed to light back and fourth until the pattern appears. Start painting as shown in the drawing with the brown pencil and than with the yellow pencil. Painting the unassembled moulded part is most convenient. Paint the tower segments with the yellow pencil only.

On peut colorier les tuiles avec des crayons de couleur jaunes et bruns du commerce (non fournis) pour assurer une décoration plus attrayante. Les tuiles à colorer sont rendues optiquement visibles par un poli spéculaire. Tournez les parties de toit légèrement en va et vient jusqu'à ce que le dessin apparait. Commencez la coloration en fonction du dessin avec le crayon à couleur brun, ensuite avec le crayon jaune. Le plus facile est de réaliser la coloration sur la pièce moulée par injection non montée. Les segments de tour ne seront peints qu'avec le jaune.

Om een nog mooier effect te krijgen kunnen de dakpannen kunnen met behulp van gele en bruine viltstiften (niet bijgesloten) worden bewerkt. De te kleuren dakpannen zijn aan hun glans te herkennen. Als de dakdelen een beetje in het licht worden bewogen, wordt het patroon zichtbaar. Schilder eerst de dakpannen die bruin moeten worden zoals aangegeven in het schema en schilder daarna de gele pannen. Schilder het dakdeel voordat u het vastlijmt. De torensegmenten worden alleen met geel beschilderd.

V

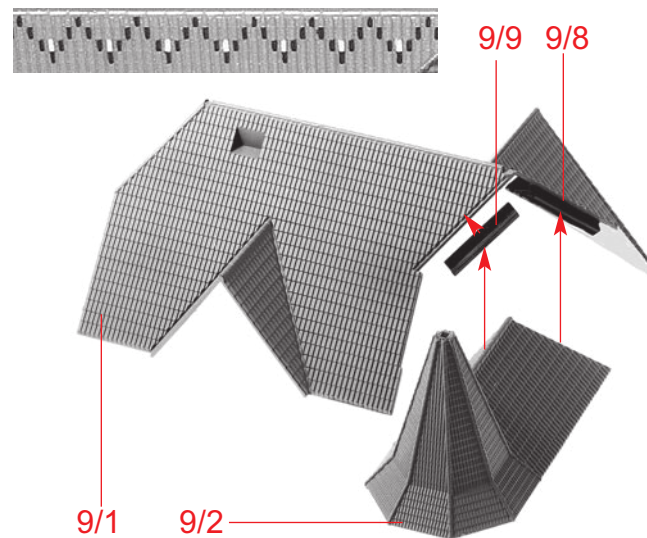



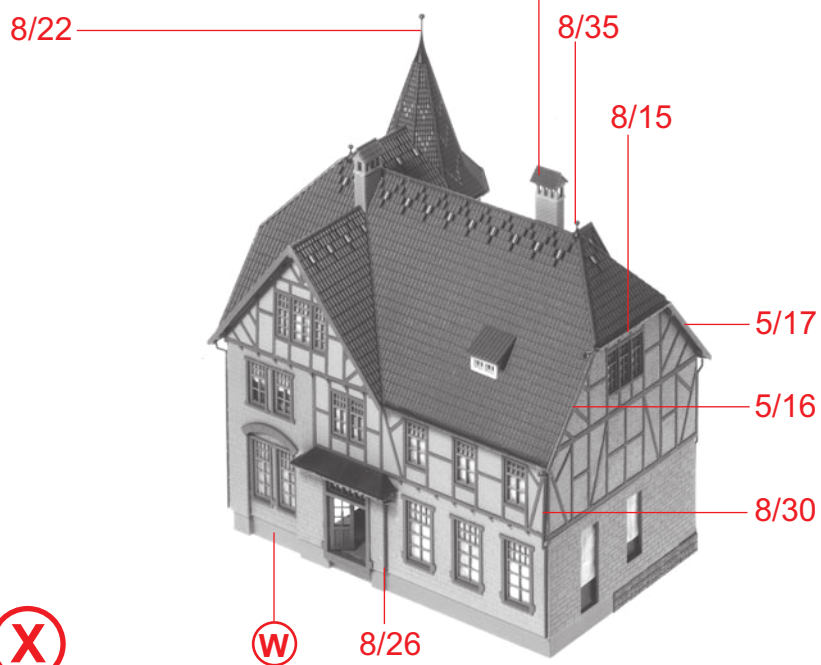
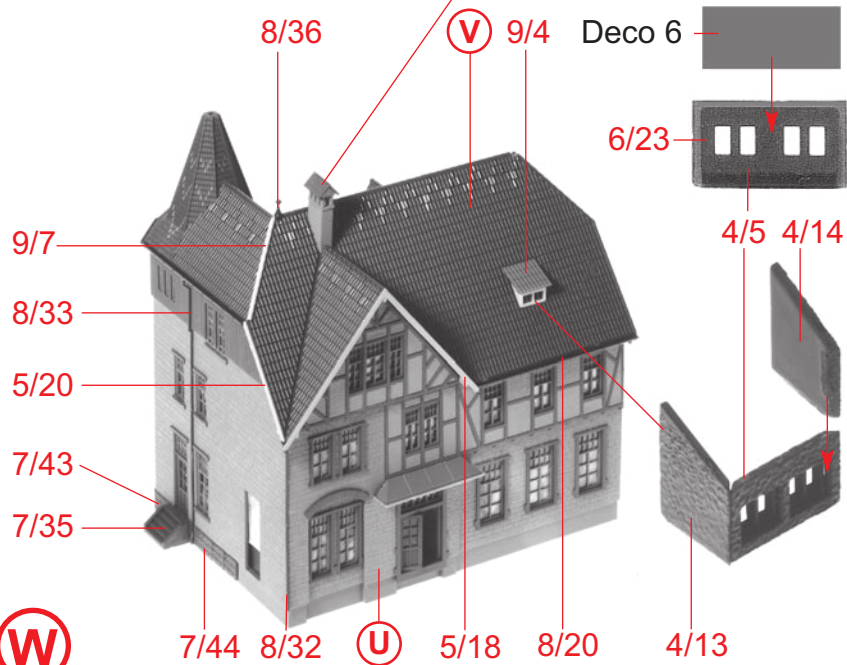
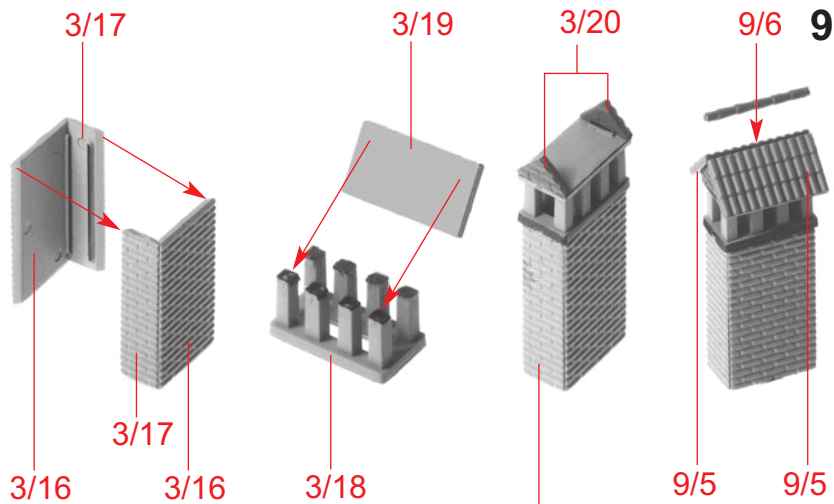
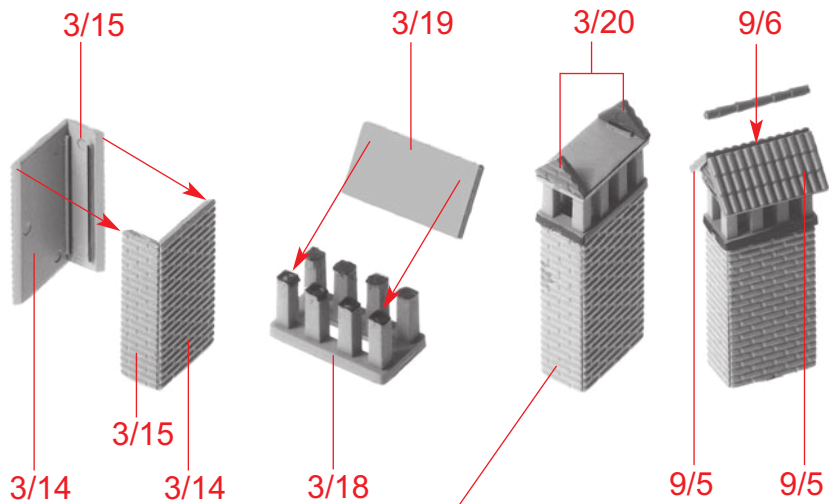

10



Deco 10

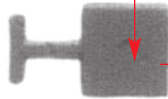

8/13

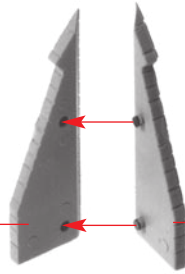

3/13

3/12

Deco 8



11/18

Deco 9



11/18

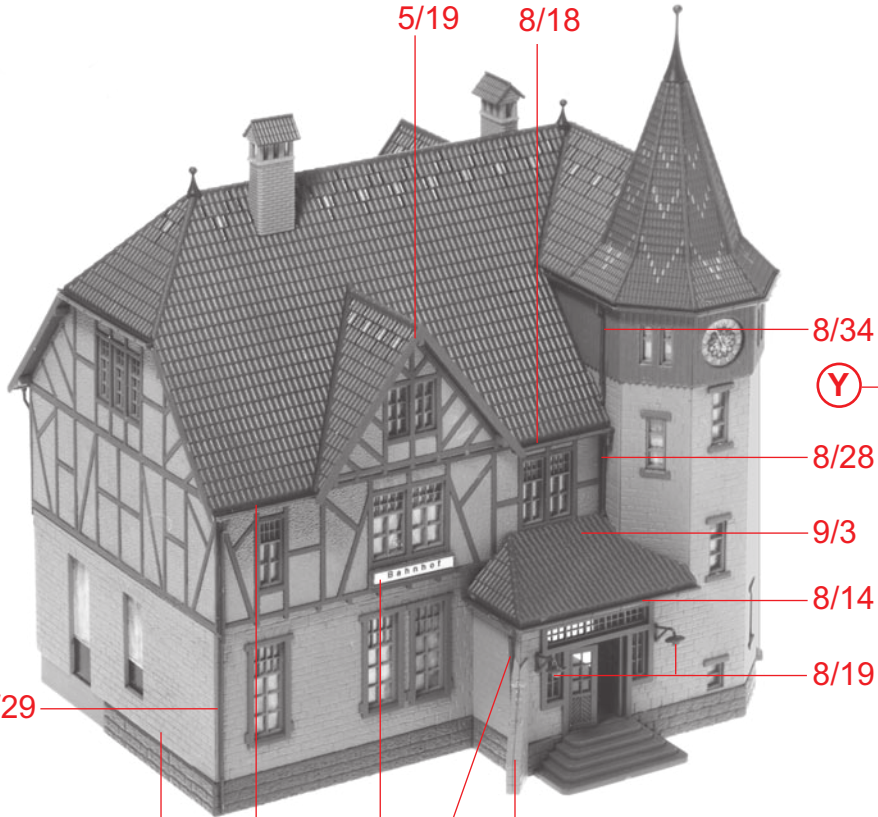

8/29

5/19

8/18

8/34

8/28

9/3

8/14

8/19



8/17



8/27

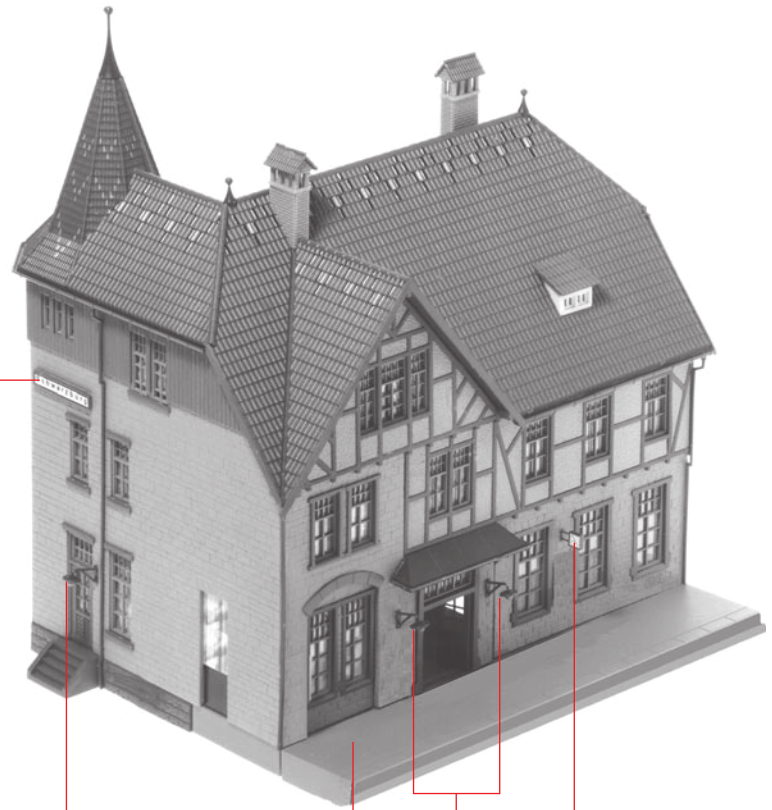

8/19

2/7

8/19



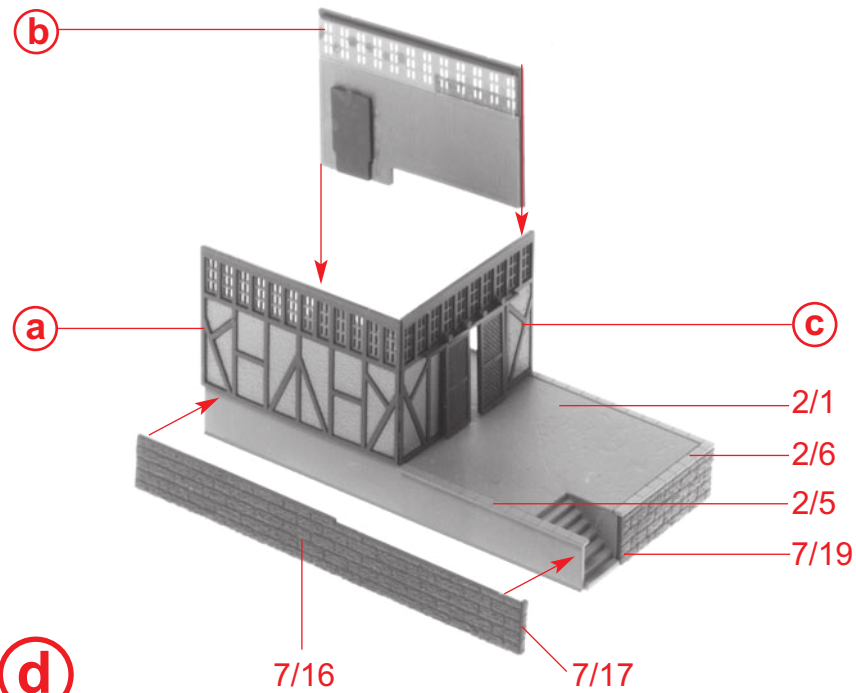
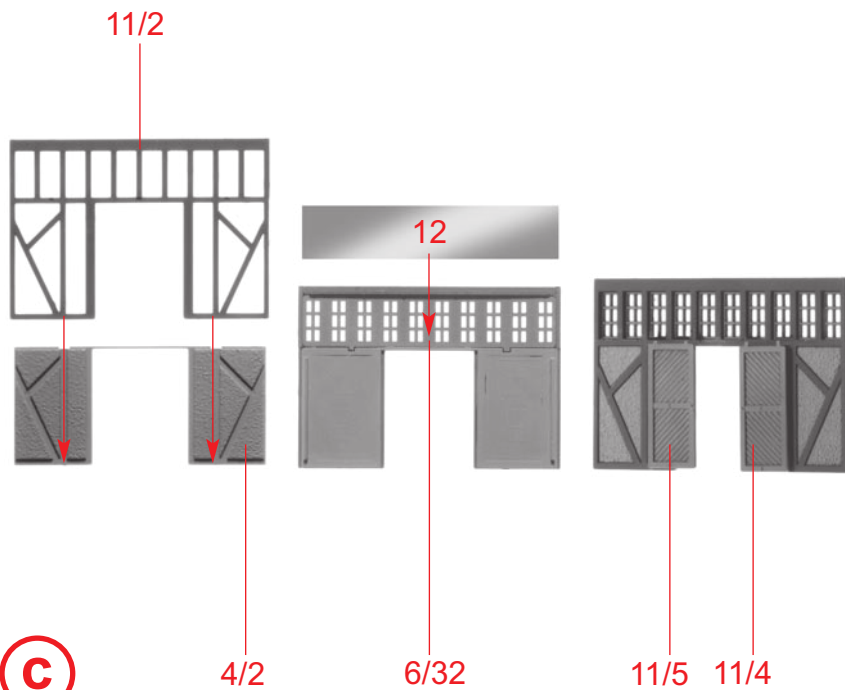
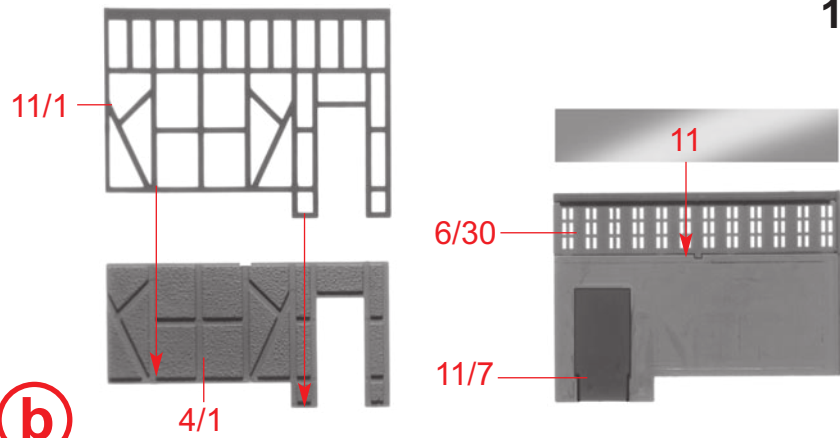
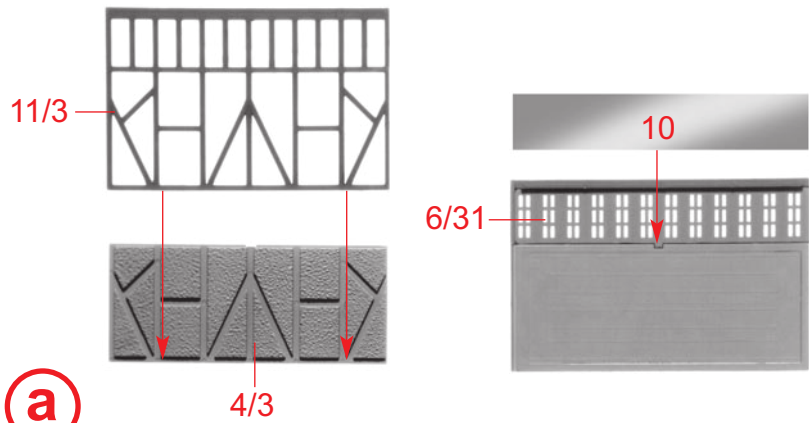



12

11/8 nicht kleben  
do not glue  
ne pas coller  
niet lijmen

Art. Nr. 180671:  
Beleuchtung, liegt nicht bei  
Illumination, not included  
Eclairage, non jointe  
Verlichting, niet bijgevoegd

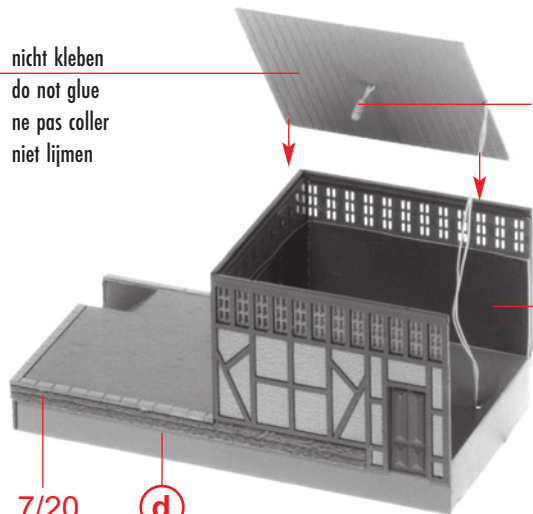

Papiermaske  
Papermask  
Masque  
Masker  
**M6**

**e**

7/20

**d**

**f**

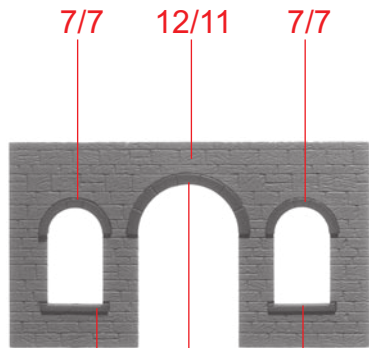
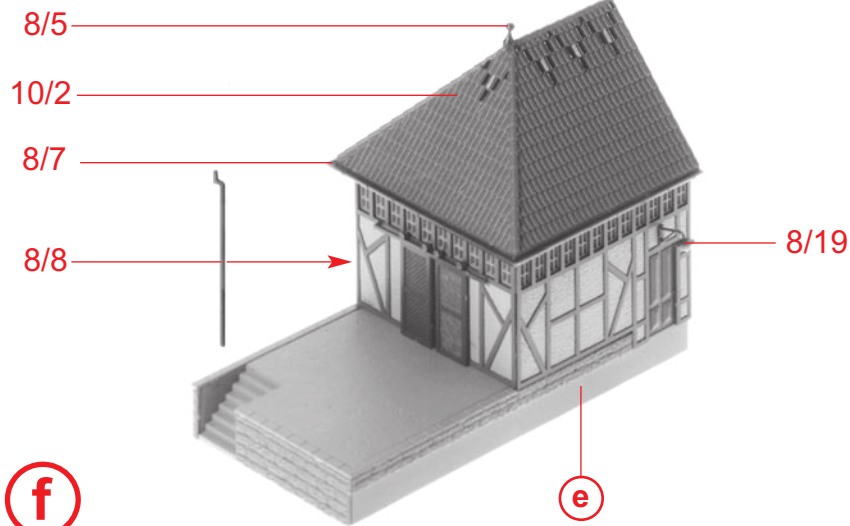

**g**

7/3

7/5

7/3

nicht kleben  
do not glue  
ne pas coller  
niet lijmen

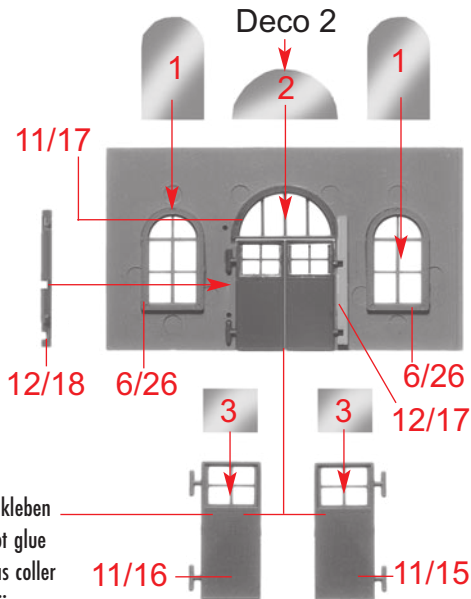

**h**

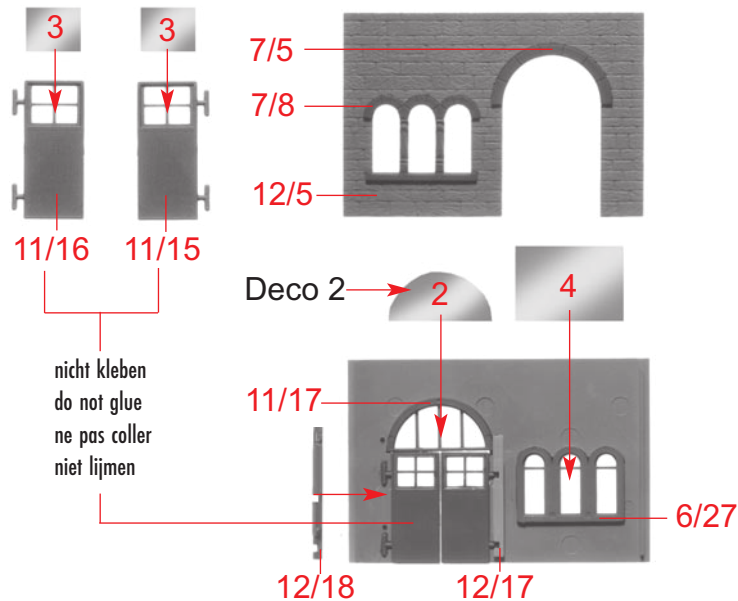



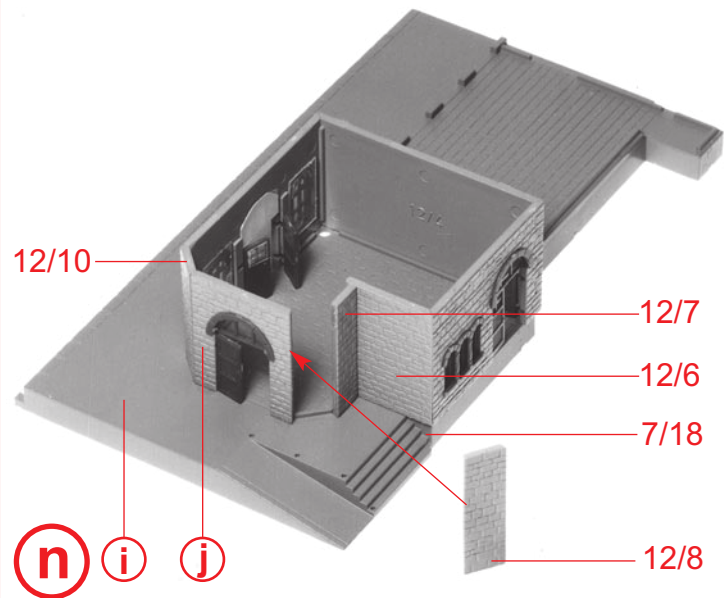
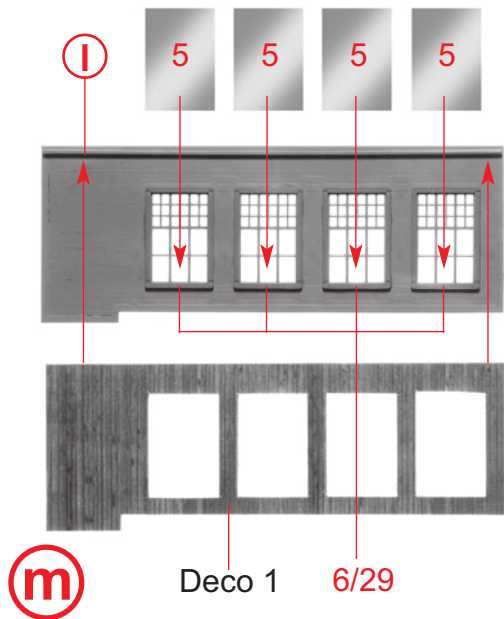
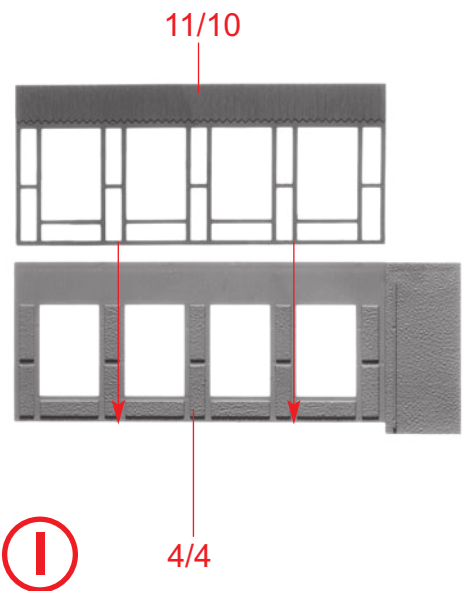
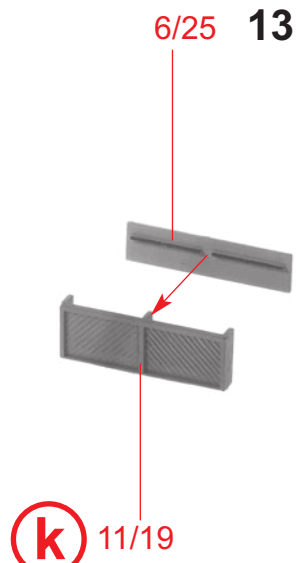
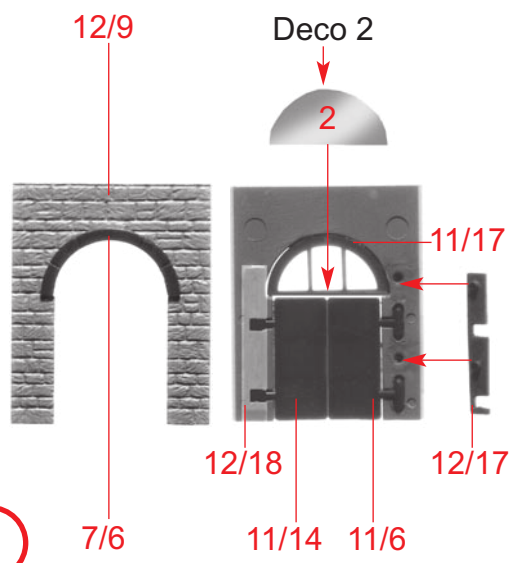
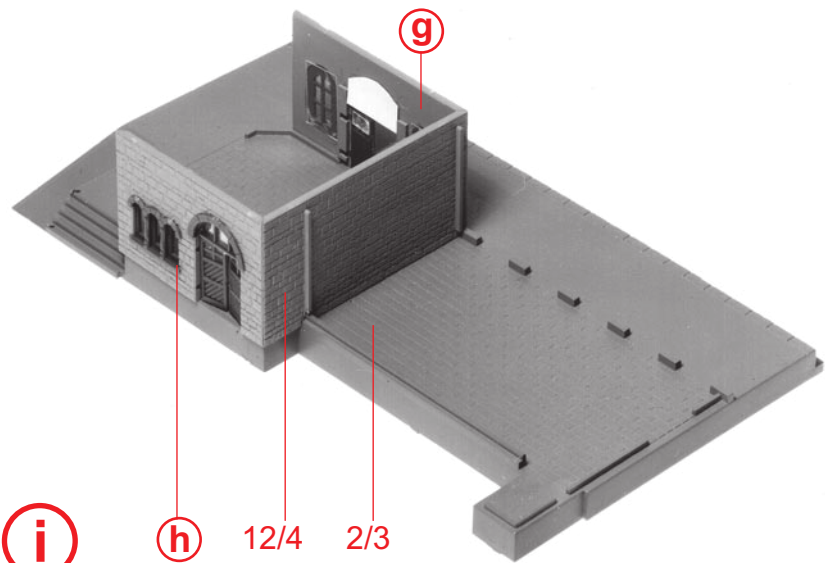

14

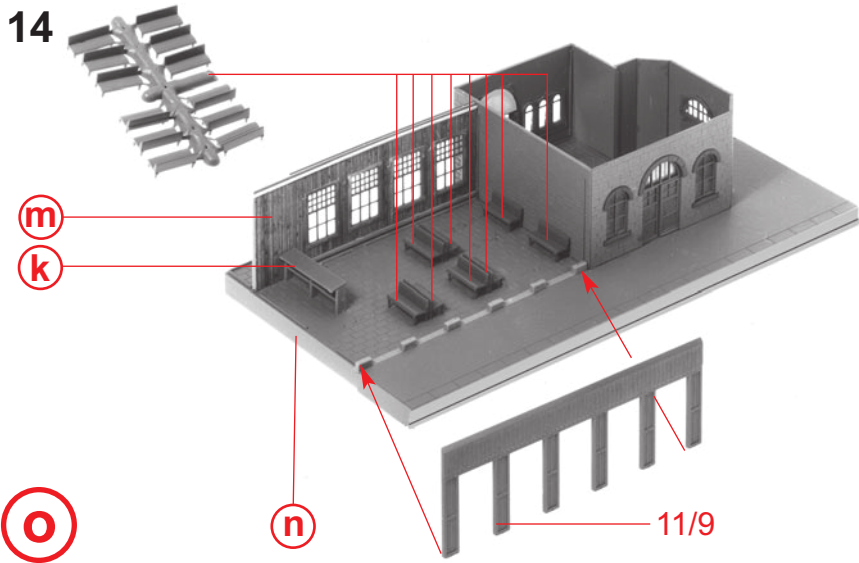

m  
k

o

n

11/9

12/1

p

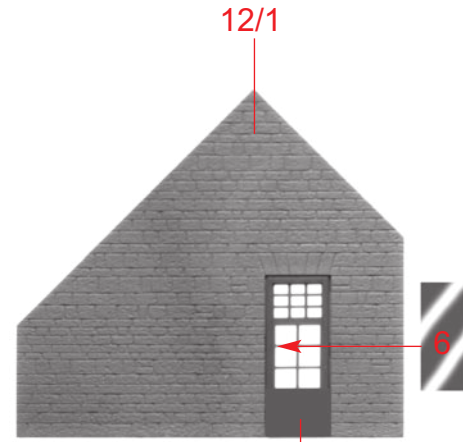

11/13

11/20

11/21

p

11/11

nicht kleben  
do not glue  
ne pas coller  
niet lijmen

M5

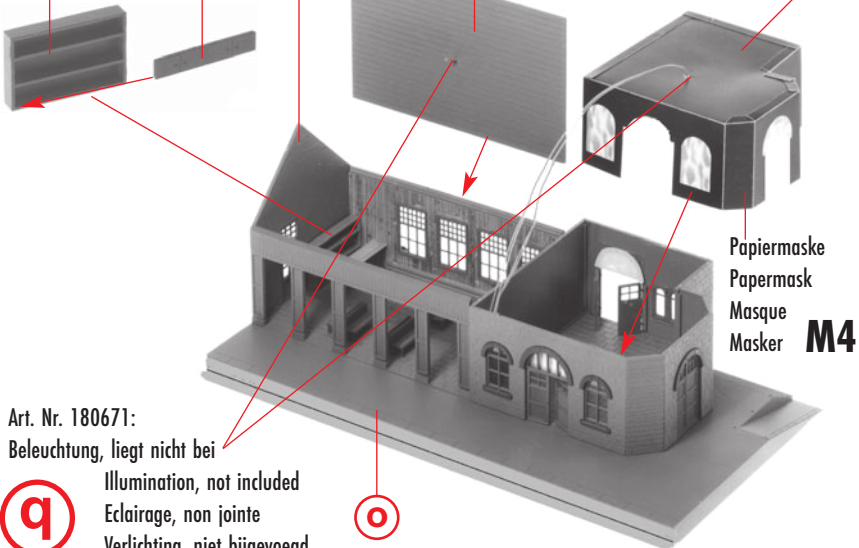

Papiermaske  
Papermask  
Masque  
Masker  
M4

Art. Nr. 180671:  
Beleuchtung, liegt nicht bei  
Illumination, not included  
Eclairage, non jointe  
Verlichting, niet bijgevoegd

q

o

7/10

7/12

r

q

7/4

7/11

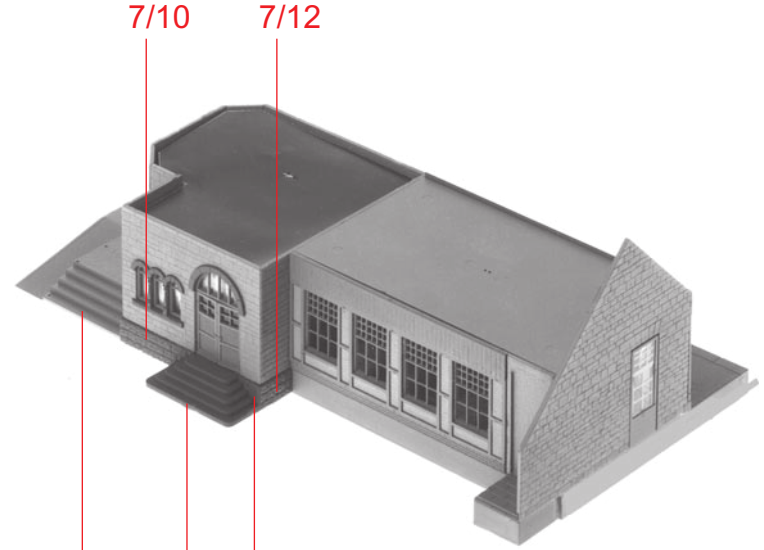

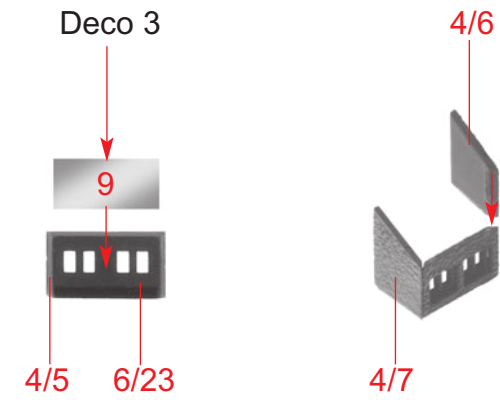
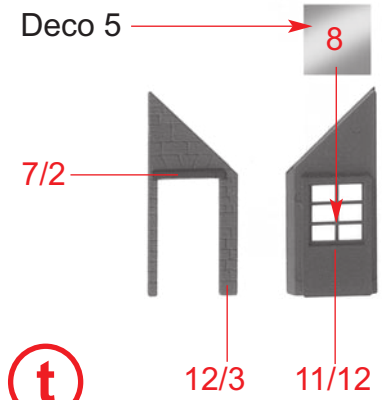
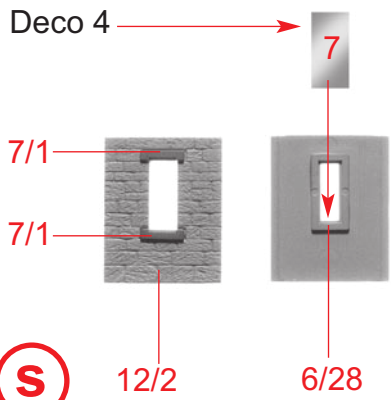

**S**

**t**

**U** 2 x

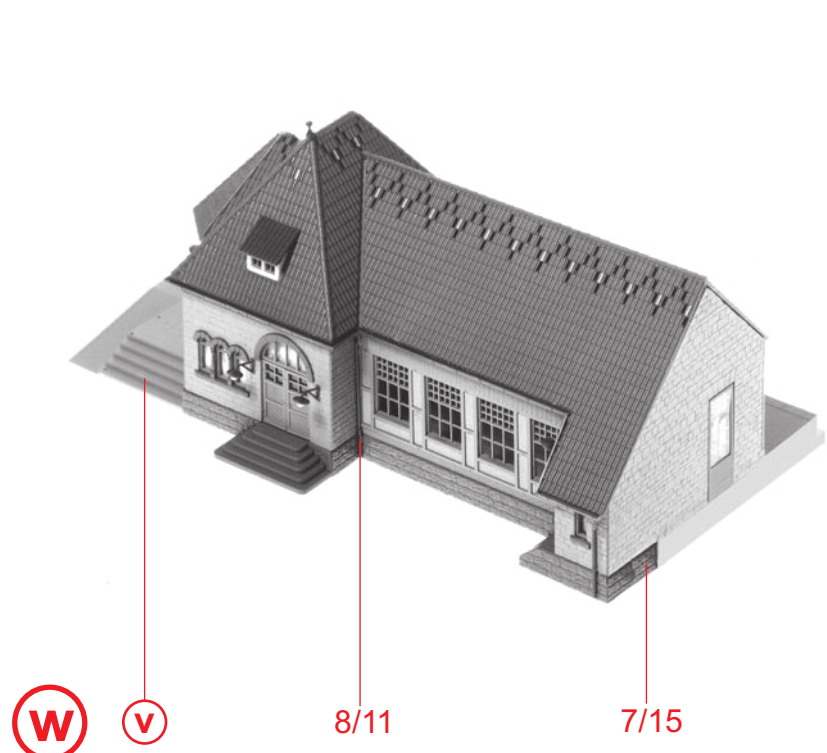
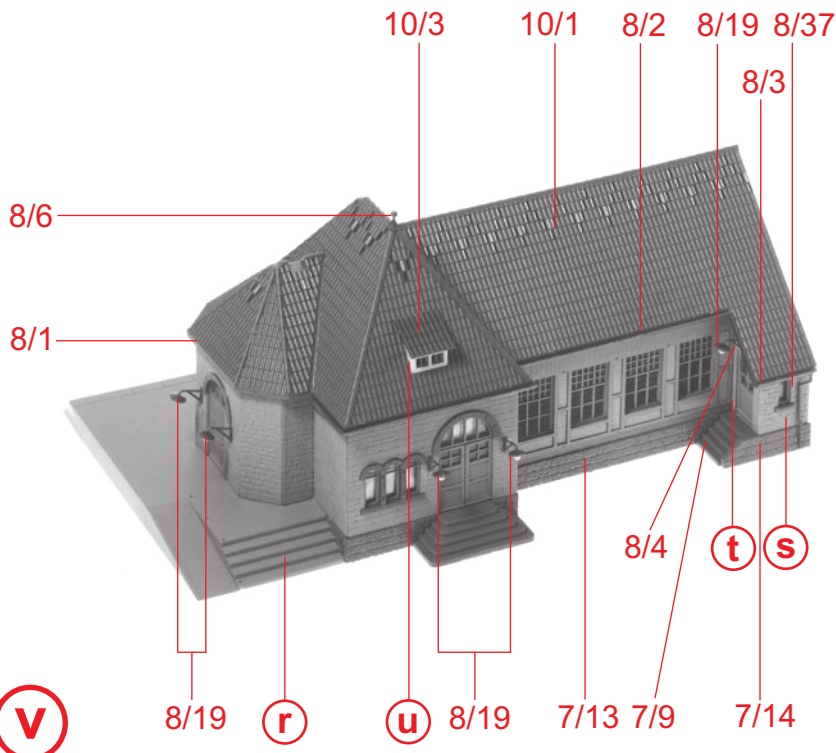

**v**

**r**

**u**

**t**

**s**

**w**

**v**

16

12/12 12/12

12/15

12/16

10/5

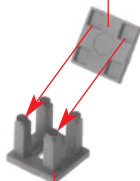
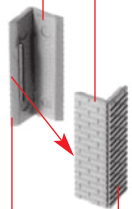

X

12/13 12/13

12/14

10/4

u

y

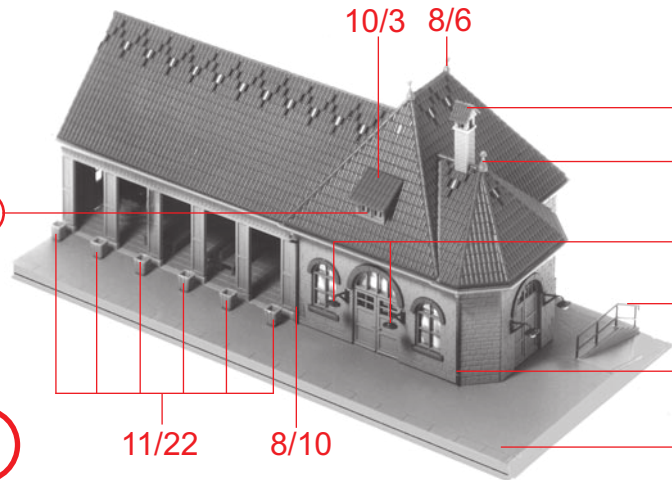

x

8/5

8/19

8/12

8/9

w

f

z

y

1/6 Deco 11

8/19

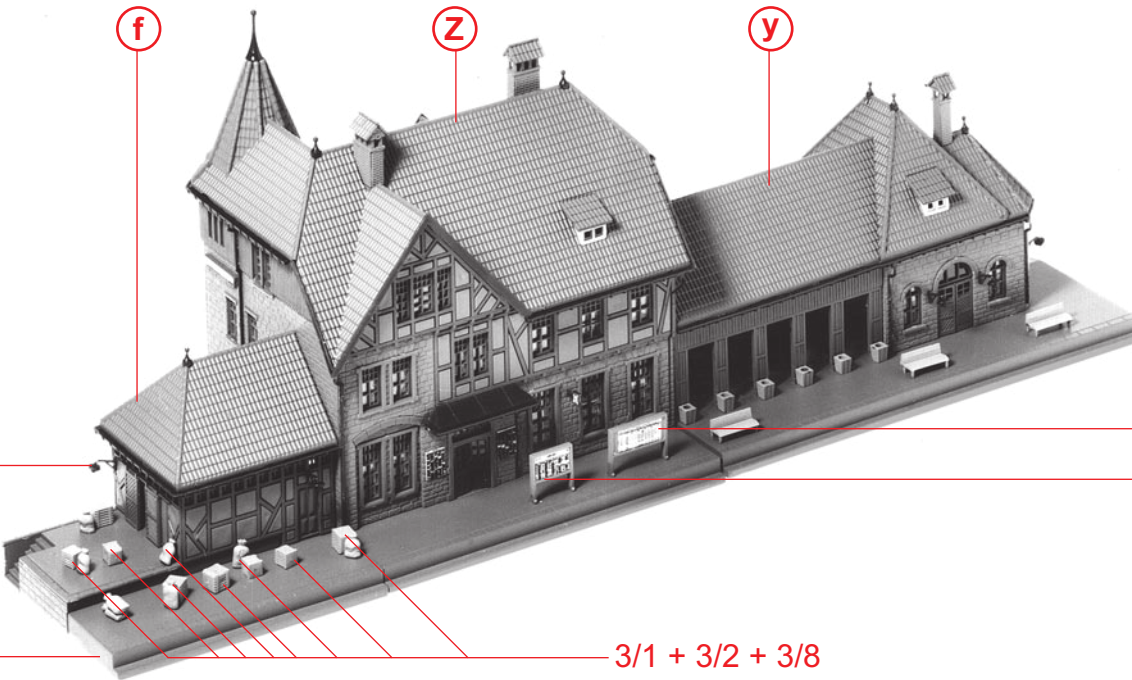

z

2/2

3/1 + 3/2 + 3/8



1/7 Deco 12