

FAHRGASTSCHIFF »OESTERREICH«

»OESTERREICH« PASSENGER SHIP
BATEAU À PASSAGERS »OESTERREICH«
PASSAGIERSCHIP »OESTERREICH«

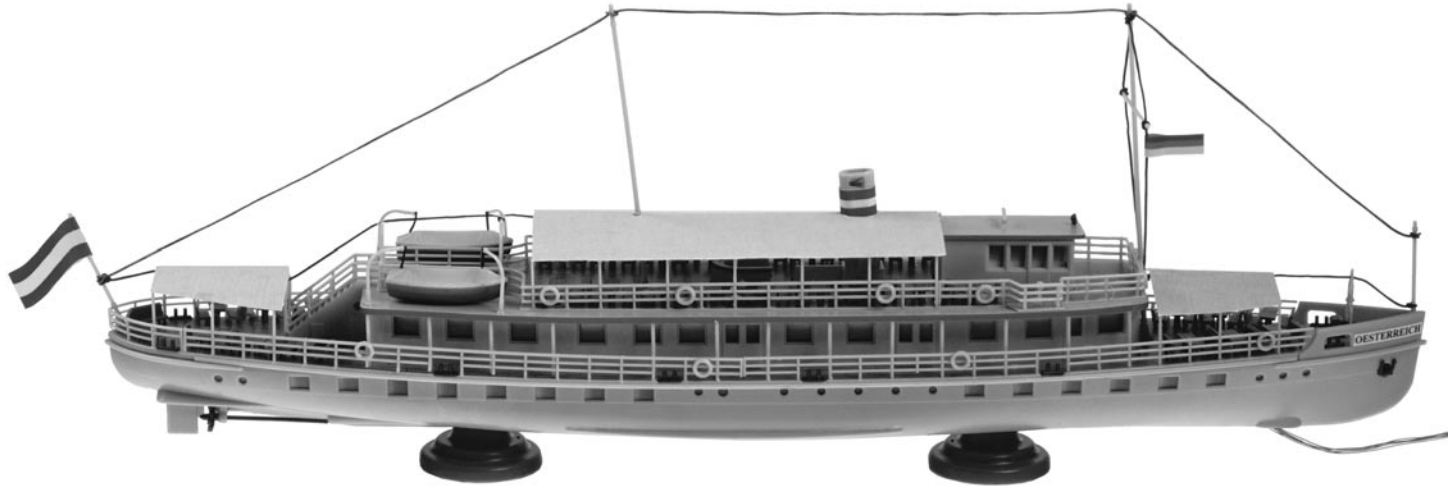

Art. Nr. 222415



Inhalt	Spritzlinge	1 A	1 x	3 A	1 x	40 B	1 x
Contents	Sprues	1 B	1 x	3 B	2 x	40 CD	2 x
Contenu	Moulages	2 AB	1 x	40 A	1 x		
Inhoud	Gietstukken						

Sa. Nr. 222 415 1

D Machen Sie sich bitte vor Beginn des Bastelns mit dem Bausatzinhalt und der Anleitung vertraut und prüfen Sie die Vollständigkeit. Im Reklamationsfall gilt die gesetzliche Gewährleistungspflicht. Sollte ein Teil fehlen, übersenden Sie bitte den Teilwunsch und den Kaufbeleg an: Gebr. FALLER GmbH, Kundendienst, Kreuzstraße 9, D-78148 Gütenbach, kundendienst@faller.de. Sollten Sie einmal weitere Ersatzteile benötigen, senden wir Ihnen den benötigten Spritzling, bei Verfügbarkeit, gerne kostenpflichtig zu. Bitte beachten Sie, dass produktionsbedingt Einzelteile übrig bleiben können.

GB Before building your model, please familiarize yourself with the contents of the kit and the instructions for use, also checking whether the set of parts is complete. In case of any complaint, the legal guarantee obligation shall apply. Should a part be missing, please send the designation of the part required and the receipt documenting your purchase to: Gebr. FALLER GmbH, Kundendienst, Kreuzstraße 9, D-78148 Gütenbach, kundendienst@faller.de. Should you require further spare parts one day, we shall be pleased to send you, with costs, the required sprue, if it is available. Please note that, on grounds of the production process, some single injection molded parts may be superfluous.

F Avant de commencer votre modèle, veuillez vous familiariser avec le contenu du kit et la notice d'emploi, et contrôlez que le lot de pièces est complet. En cas de réclamation, il s'appliquera l'obligation de garantie légale. Au cas où une pièce manquerait, veuillez envoyer la désignation de la pièce souhaitée et le bon d'achat à: Gebr. FALLER GmbH, Kundendienst, Kreuzstraße 9, D-78148 Gütenbach, kundendienst@faller.de. Au cas où vous auriez besoin un jour d'autres pièces détachées, nous vous enverrons volontiers la grappe requise, si elle est disponible, contre paiement. Veuillez noter que, pour des raisons de production, il se peut que des pièces détachées soient superflues.

NL Maak uzelf vóór het bouwen vertrouwd met de inhoud van het bouwpakket en met de handleiding en controleer de volledigheid. In geval van reclamatie geldt de wettelijke garantieverplichting. Mocht er een onderdeel ontbreken, stuur het verzoek om het gewenste onderdeel en het aankoopbewijs dan naar: Gebr. FALLER GmbH, klantenservice, Kreuzstraße 9, D-78148 Gütenbach, kundendienst@faller.de. Als u ooit meer reserveonderdelen nodig hebt, sturen wij het benodigde gietstuk, indien beschikbaar, graag tegen betaling naar u op. Let op: om productieredenen kunnen losse onderdelen overblijven.

Für die Montage benötigen Sie Plastik-Klebstoff und Expert Lasercut-Kleber.

Wir empfehlen:

FALLER-Klebstoff SUPER-EXPERT (Art. Nr. 170490)
FALLER-Klebstoff EXPERT (Art. Nr. 170492)
FALLER-Sekundenkleber (Art. Nr. 170500)
FALLER-Spezial-Seitenschneider (Art. Nr. 170688)
FALLER-Bastelmesser (Art. Nr. 170687)

For mounting you need plastic cement and Lasercut cement.

Our recommendation:

FALLER cement SUPER-EXPERT (Art. No. 170490)
FALLER cement EXPERT (Art. No. 170492)
FALLER-Instant modelling cement (Art. No. 170500)
FALLER special side cutter (Art. No. 170688)
FALLER modeller's knife (Art. No. 170687)

Pour le montage, utiliser de la colle plastique et de la colle Lasercut.

Nous vous recommandons les produits suivants:

Colle FALLER SUPER-EXPERT (Art. Nr. 170490)
Colle FALLER EXPERT (Art. Nr. 170492)
Colle FALLER-Rapide (Art. Nr. 170500)
Pince coupante diagonale spéciale FALLER (Art. Nr. 170688)
Couteau de bricolage FALLER (Art. Nr. 170687)

Voor de montage heeft u plasticlijm en Lasercut lijm nodig.

Wij adviseren:

FALLER-plasticlijm SUPER-EXPERT (Art. Nr. 170490)
FALLER-plasticlijm EXPERT (Art. Nr. 170492)
FALLER-Secondenlijm (Art. Nr. 170500)
FALLER-speciaal zijknijptang (Art. Nr. 170688)
FALLER-knutselmes (Art. Nr. 170687)

Art. Nr. 170490 | 170492 | 170494
FALLER SUPER-EXPERT | EXPERT | LASERCUT



Art. Nr. 170688
SPEZIAL-SEITENSCHNEIDER



Art. Nr. 170687
FALLER-BASTELMESSER



Fensterfolie

Die beiliegende Fensterfolie entsprechend der benötigten Größe ausschneiden und vorsichtig mit wenig Klebstoff auf die Rückseite der Fensterrahmen aufkleben.

Window foil

Cut the attached window foil according the illustrations and glue it carefully with a little glue to the rear side of the window frames.

Feuillet transparent pour fenêtres

Découper le feuillet transparent pour fenêtres inclus d'après l'illustration. Coller proprement avec un peu de colle sur la face arrière du cadre des fenêtres.

Vensterfolie

De meegeleverde vensterfolie conform de afbeeldingen uitknippen of uitsnijden en voorzichtig met een beetje lijm op de achterzijde van het raam plakken.

Fensterfolie
Window foil
Feuillet transparent
Vensterfolie

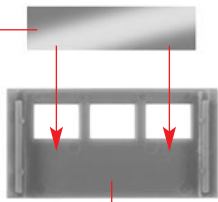

2/5

A

Fensterfolie
Window foil
Feuillet transparent
Vensterfolie

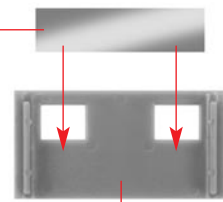

2/3

B

Fensterfolie
Window foil
Feuillet transparent
Vensterfolie

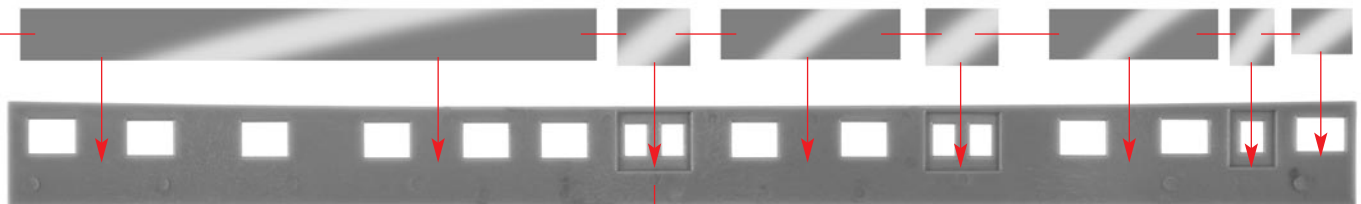

2/2

C

Fensterfolie
Window foil
Feuillet transparent
Vensterfolie

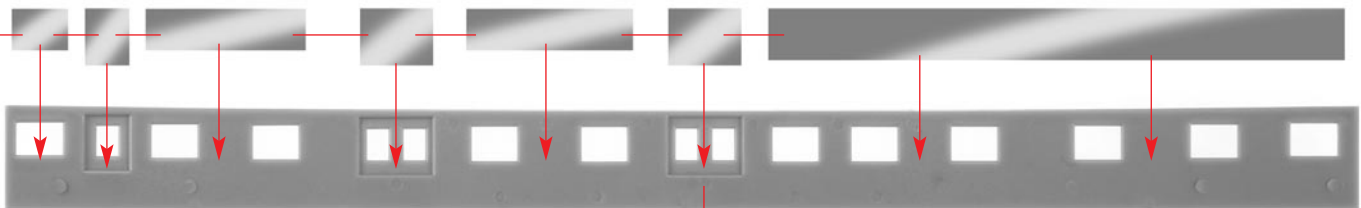

2/4

D

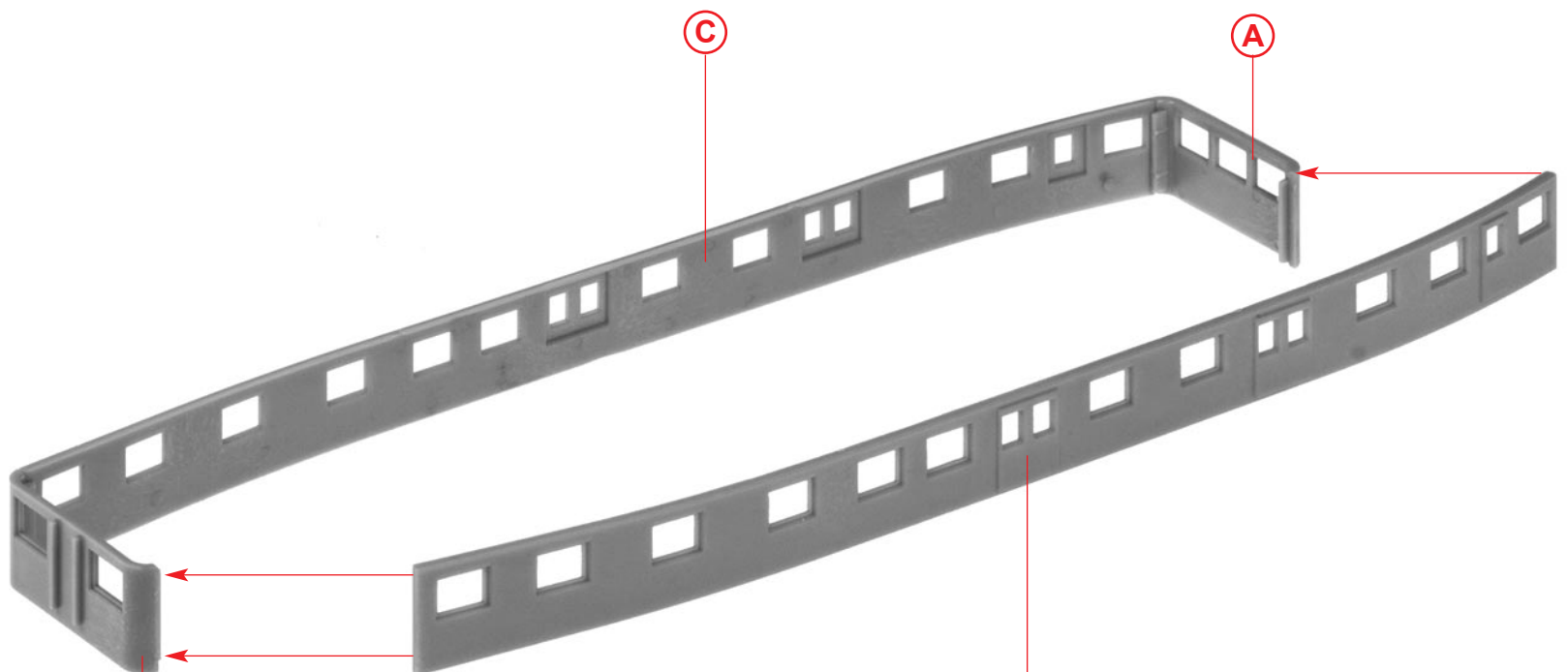

E

B

D

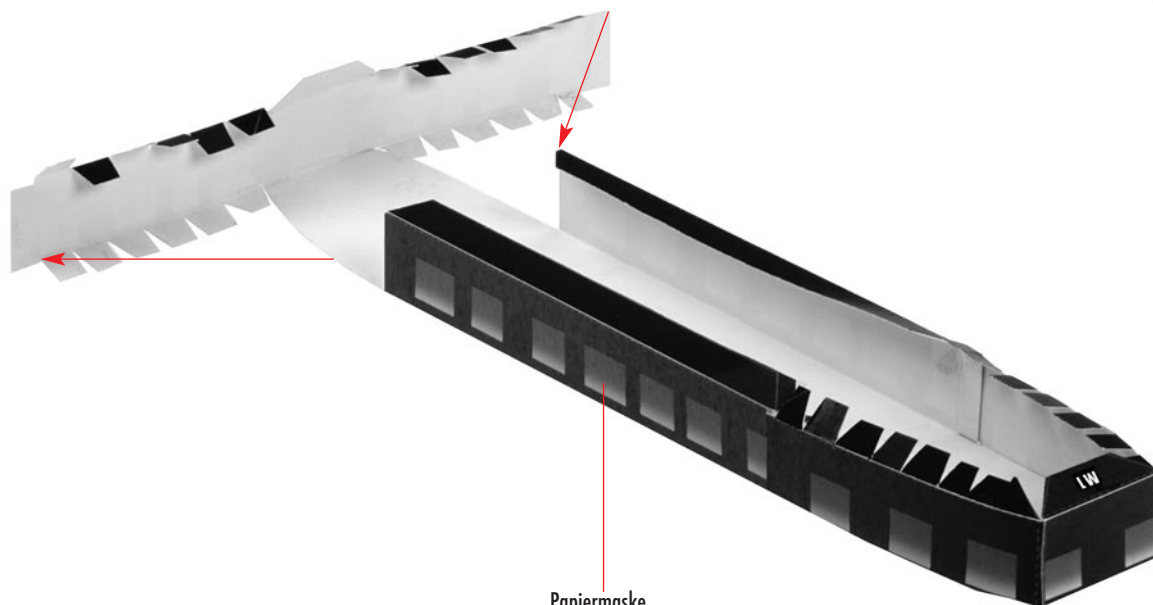

Papiermaske
Papermask
Masque
Masker **M1**

F

2/1

40/3

Art. Nr. 180653:
Beleuchtung, liegt nicht bei
Illumination, not included
Éclairage, non jointe
Verlichting, niet bijgevoegd

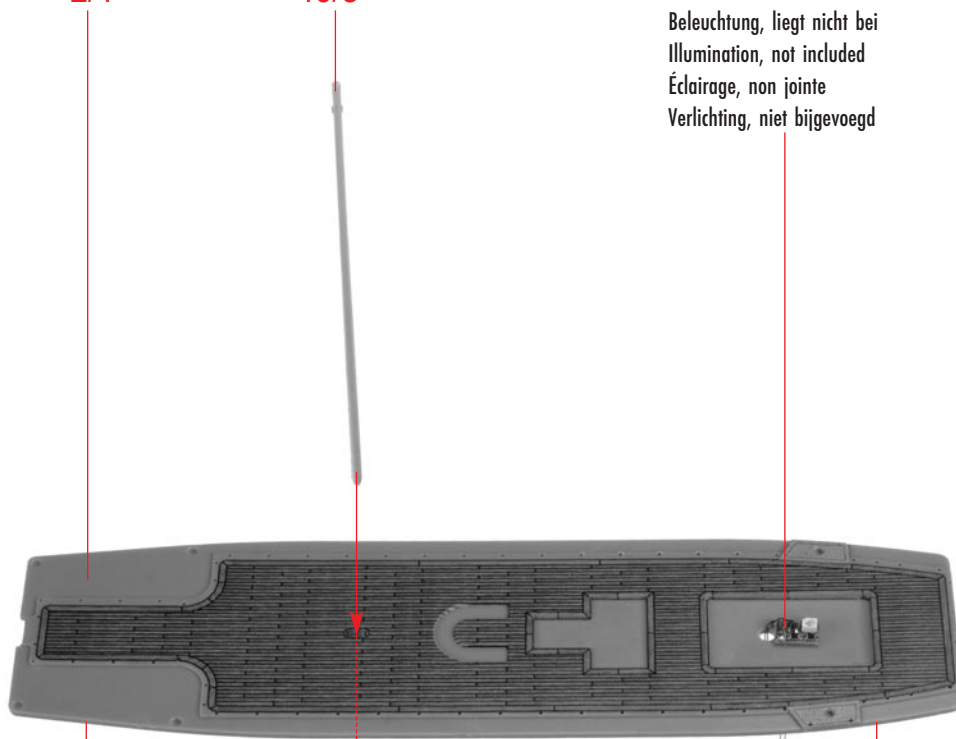

F

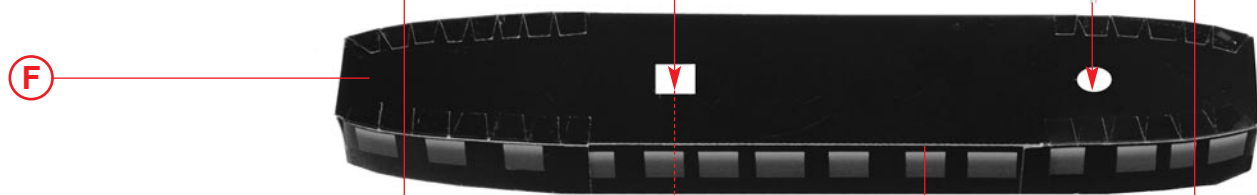

G

1/1

Art. Nr. 180653:
Beleuchtung, liegt nicht bei
Illumination, not included
Éclairage, non jointe
Verlichting, niet bijgevoegd

E

Art. Nr. 180653:
Beleuchtung, liegt nicht bei
Illumination, not included
Éclairage, non jointe
Verlichting, niet bijgevoegd

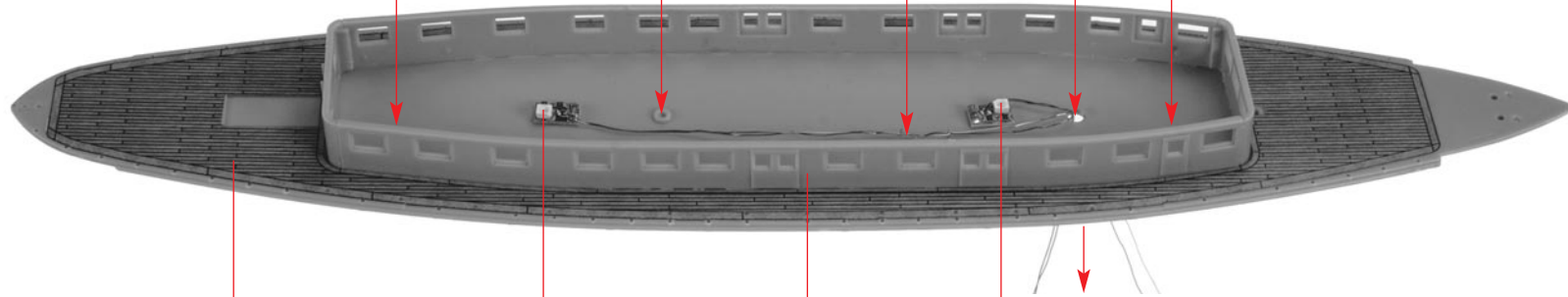

4

40/18

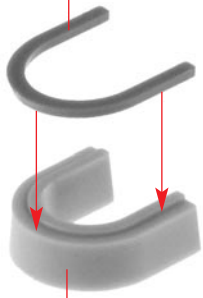

H

2/6

3/27 3/27

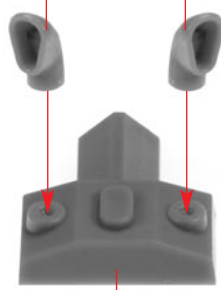

I

2/12

1/6

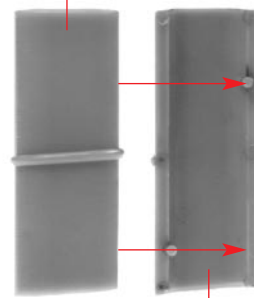

J

1/7

Deco 15



K

J

Fensterfolie
Window foil
Feuille transparent
Vensterfolie

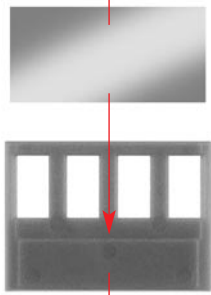

L

2/8

Fensterfolie
Window foil
Feuille transparent
Vensterfolie

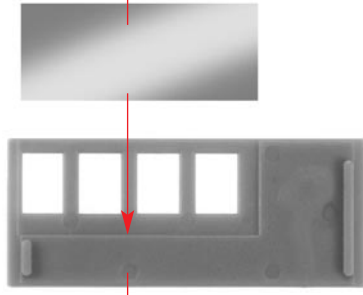

M

2/7

Fensterfolie
Window foil
Feuille transparent
Vensterfolie

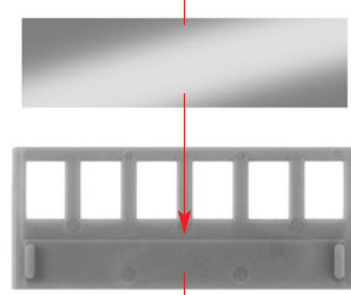

N

2/9

Fensterfolie
Window foil
Feuille transparent
Vensterfolie

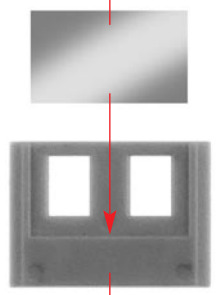

O

2/10

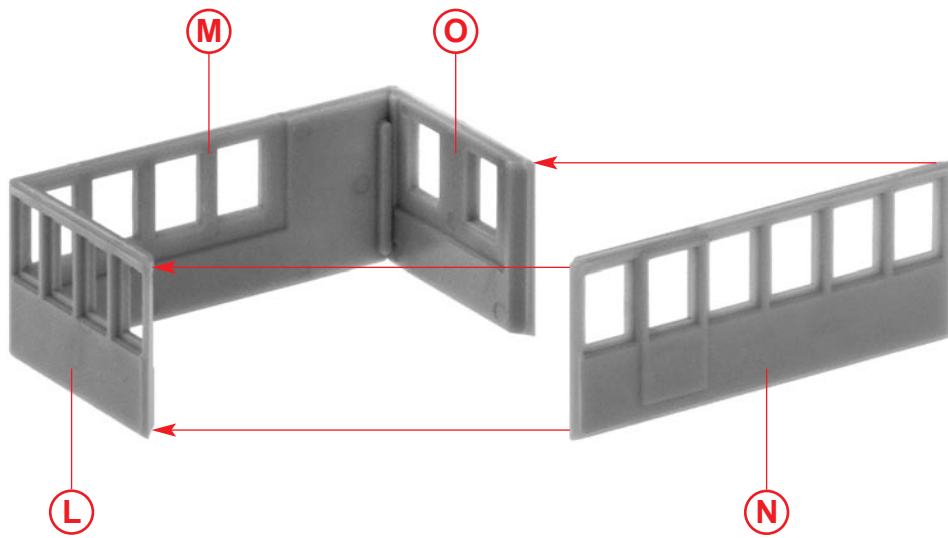

P

Fensterfolie
Window foil
Feuille transparent
Vensterfolie

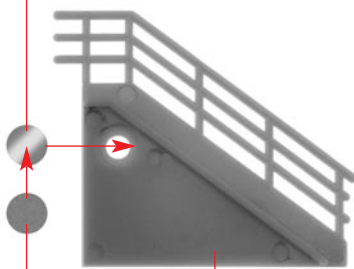

Q

Deco 5

3/6

Fensterfolie
Window foil
Feuille transparent
Vensterfolie

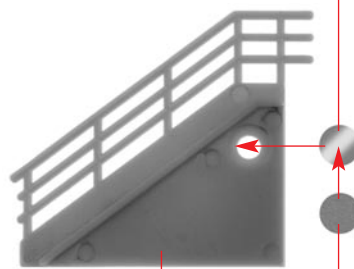

R

3/7

Deco 5

R

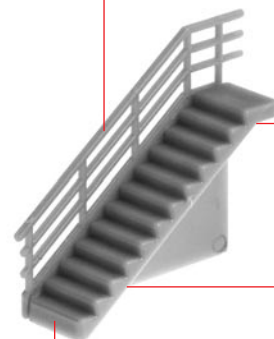

S

3/5

Q

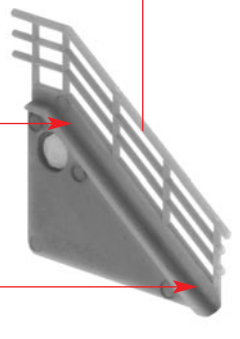

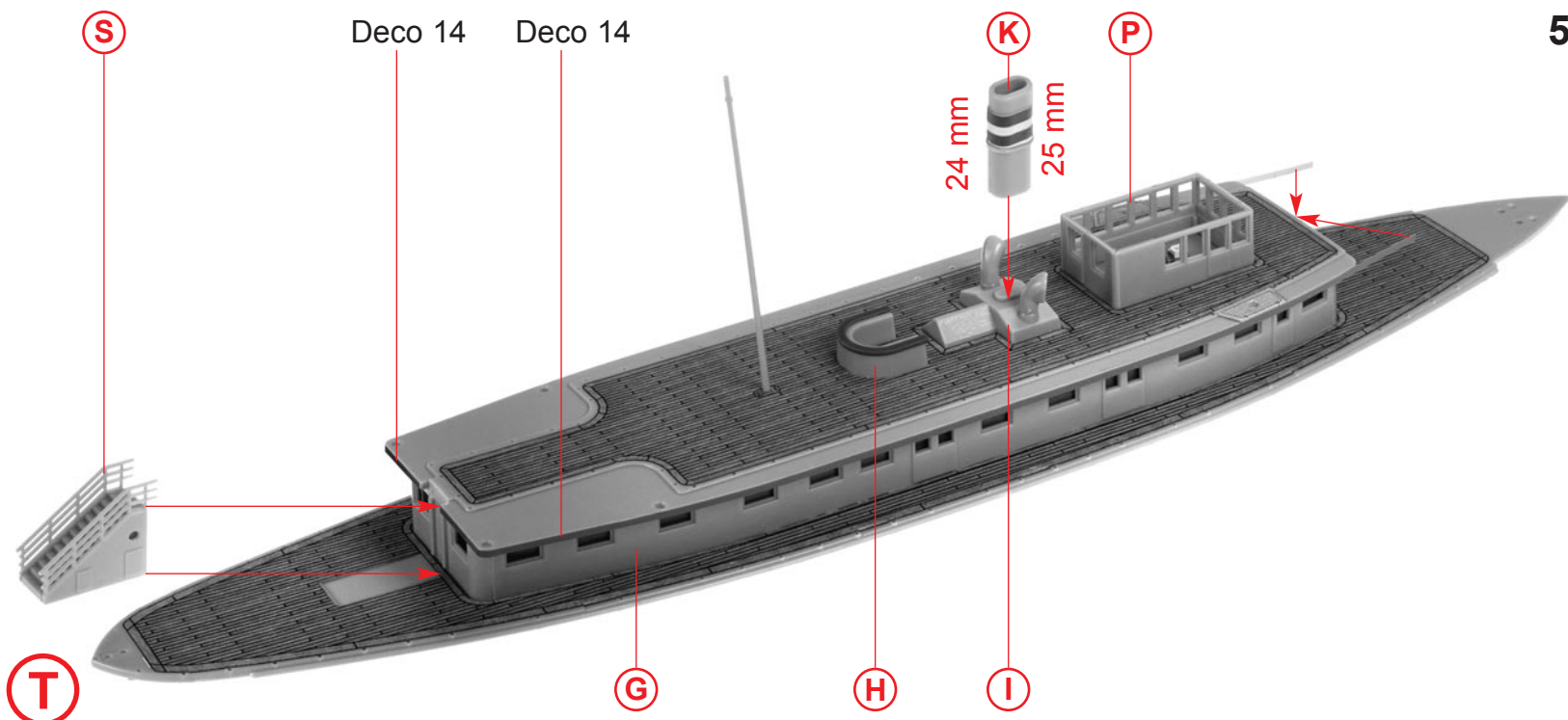

Stifte und Löcher
vorsichtig entgraten.
Carefully deburr pins
and holes.
Ébavurer soigneusement
les goupilles et les trous.
Ontbraam de pennen
en gaten zorgvuldig.

Löcher mit \varnothing 1 mm bohren.
Drill holes with a dia. of 1 mm.
Percer des trous avec \varnothing 1 mm.
Gaten met \varnothing 1 mm boren.

U 13 x 3/23

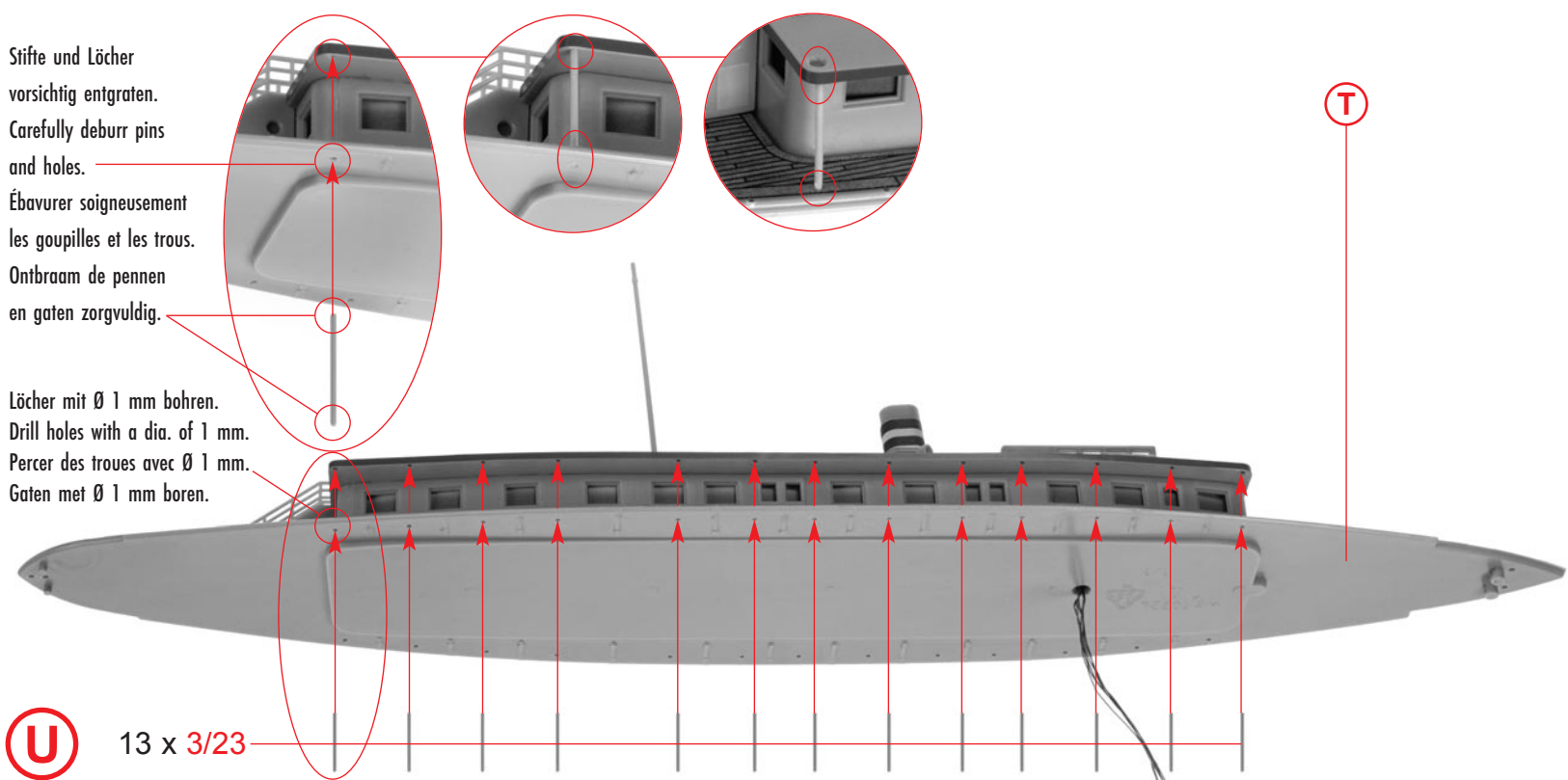

V

U

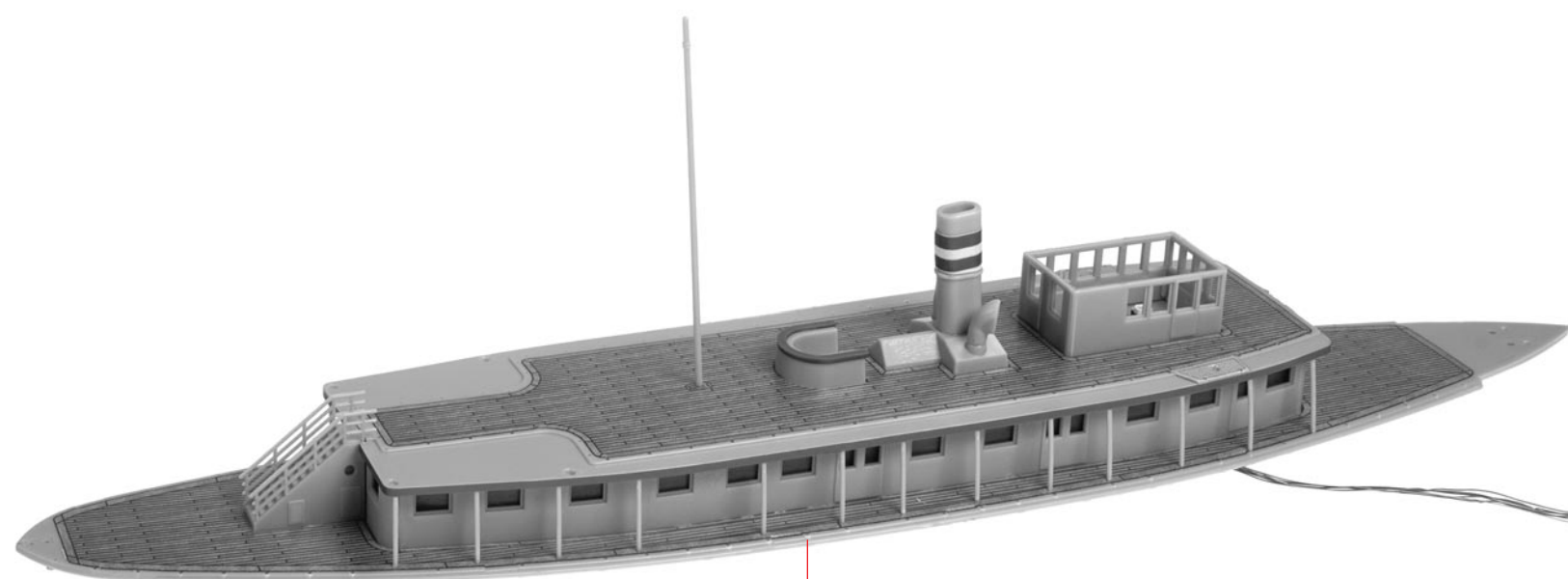

6 Stifte und Löcher
vorsichtig entgraten.
Carefully deburr pins
and holes.
Ébavurer soigneusement
les goupilles et les trous.
Ontbraam de pennen
en gaten zorgvuldig.

Löcher mit Ø 1 mm bohren.
Drill holes with a dia. of 1 mm.
Percer des trous avec Ø 1 mm.
Gaten met Ø 1 mm boren.

W 13 x 3/23

V

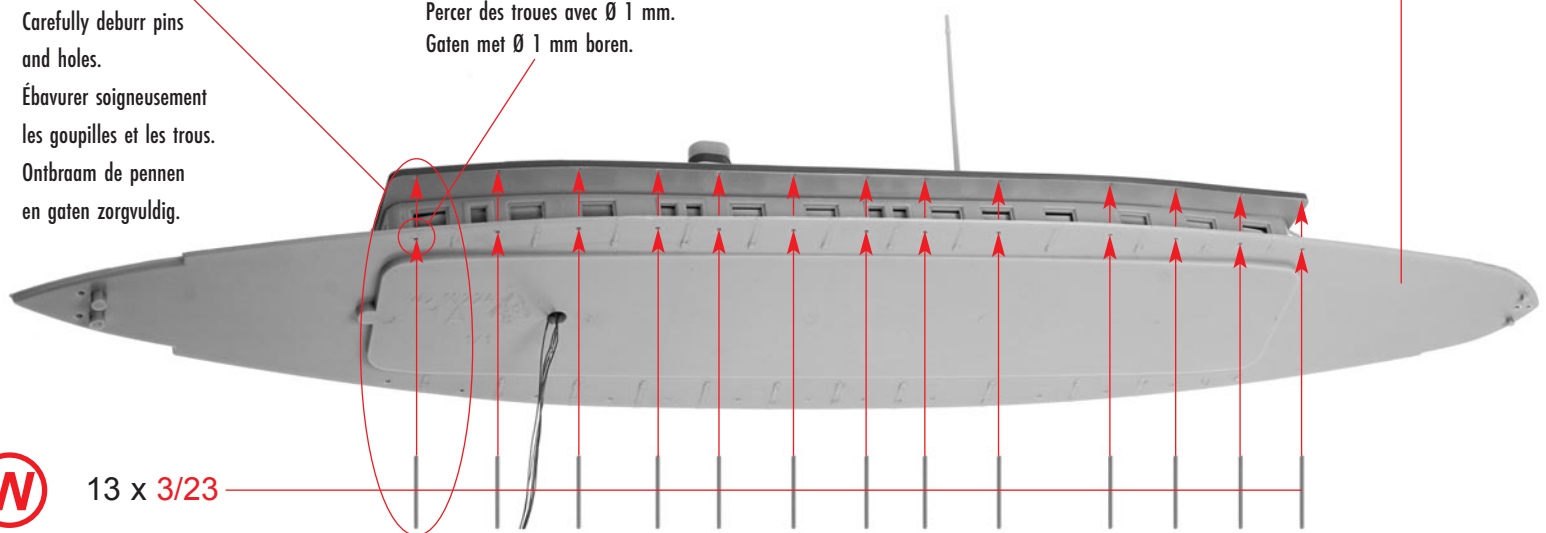

X

W

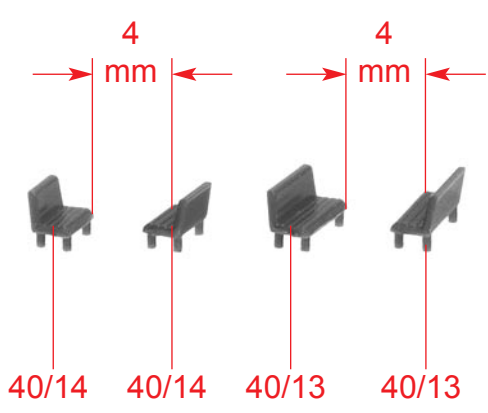
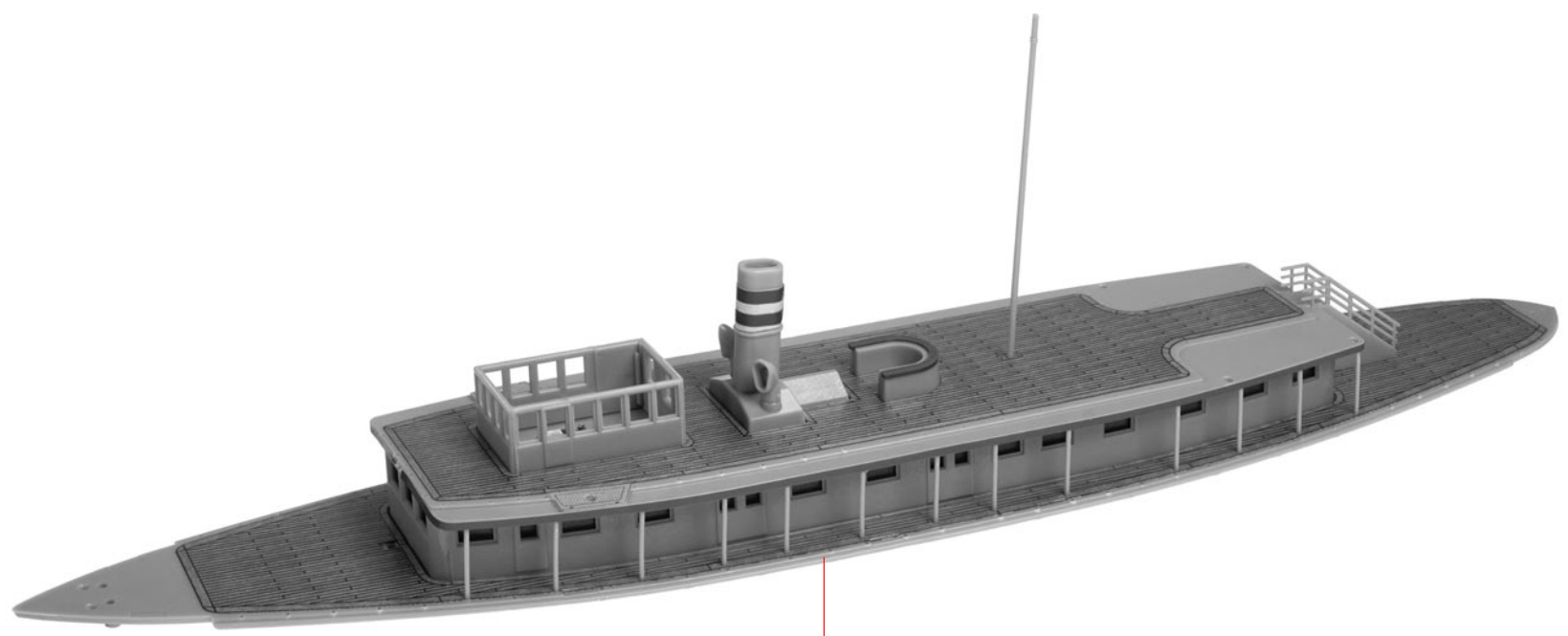

Y 2 x

Sekundenkleber verwenden.
Use instant modelling cement.
Utilisez la colle rapide.
Gebruik secondenlijm.

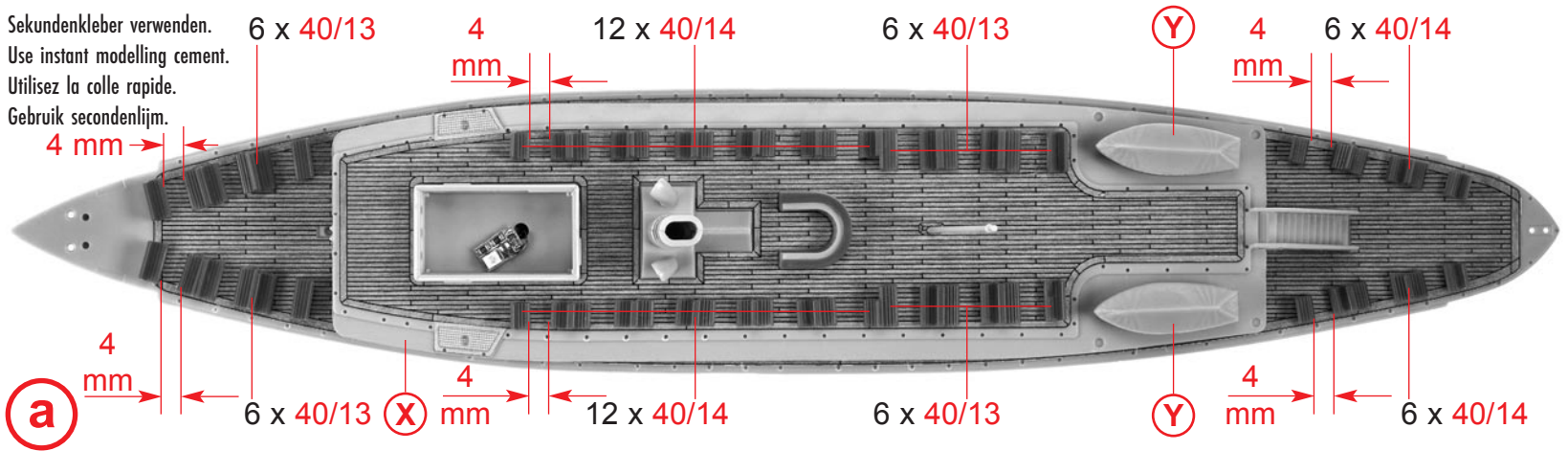

a

X

Y

Deco 10

Deco 11

Deco 9

Deco 12



(b) 18 x 40/16 Variante

(c) 12 x 40/15 Variante

(d) **(b)** **(c)**

Sekundenkleber verwenden.
Use instant modelling cement.
Utilisez la colle rapide.
Gebruik secondenlijm.

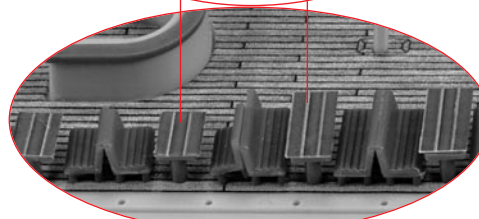
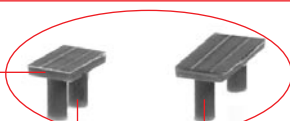

6 x **(c)**

12 x **(b)**

6 x **(c)**

6 x **(b)**

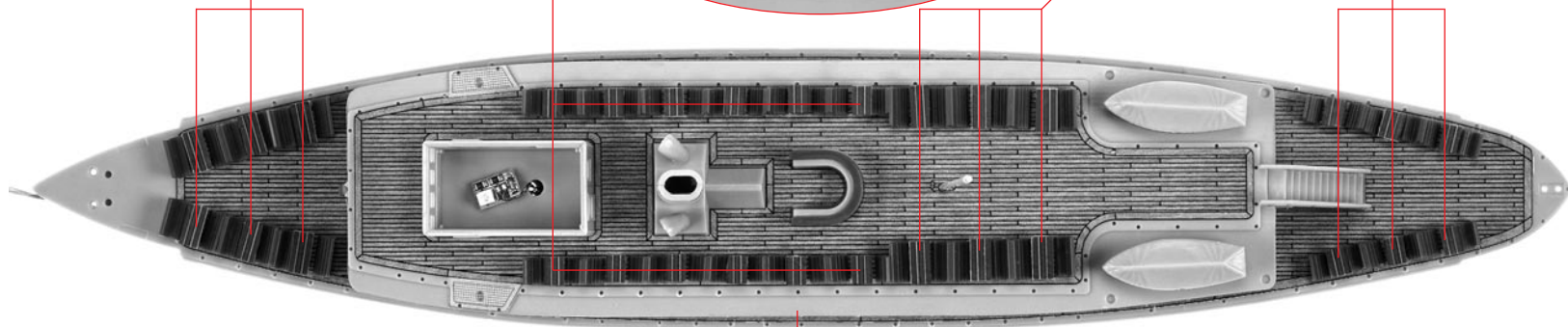

(e)

(a)

Bemalungshinweis Handlauf, rot, siehe Verpackung.
Painting instructions for handrail, red, see packaging.
Indication pour la peinture Main courante, rouge, voir emballage.
Schilderinstrucies voor leuning, rood, zie verpakking.

3/18

3/15

3/21

3/8

3/19

3/13

3/20 3/16

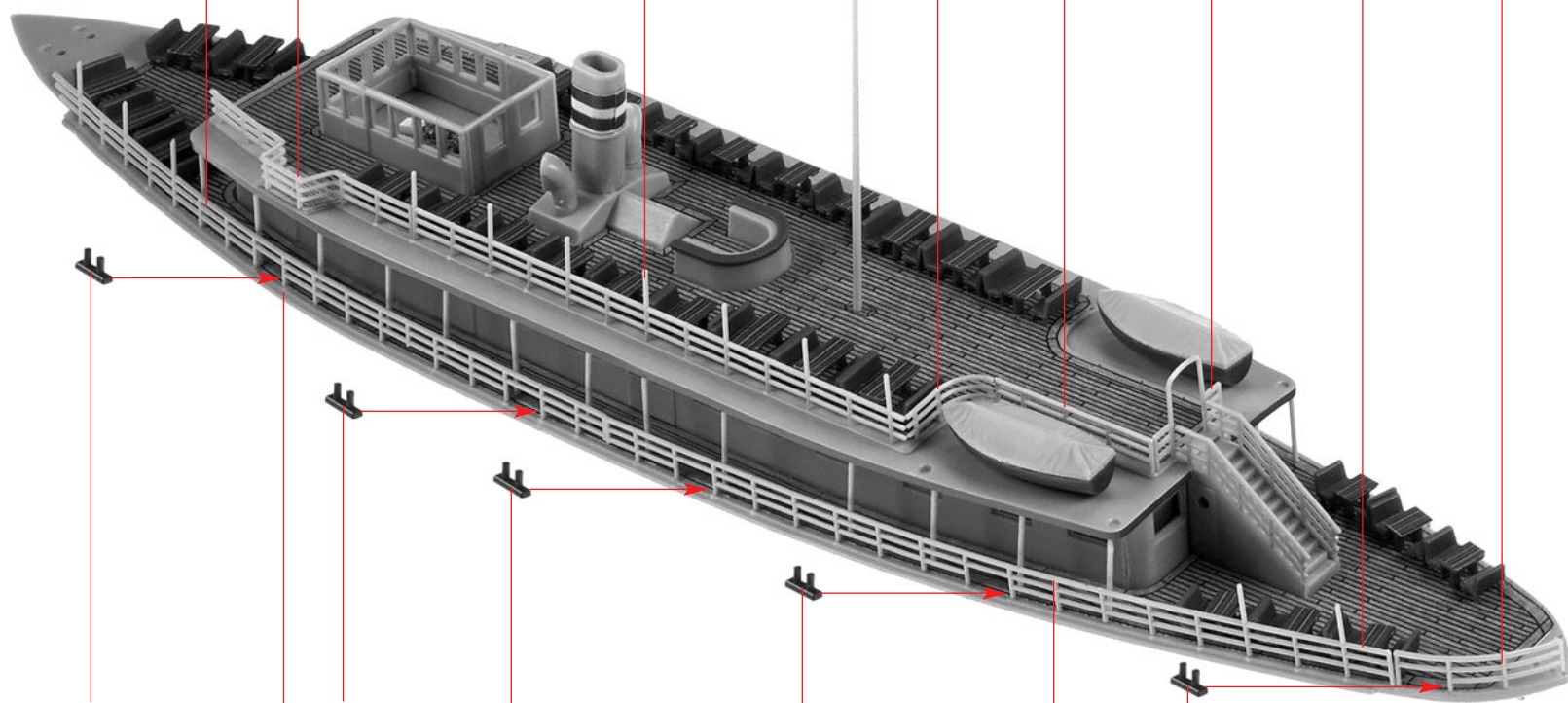

40/8

40/8

40/8

40/8

3/19

40/8

(f)

(e)

8

Faden (2 x 30 mm).
Cord (2 x 30 mm).
Aiguillée (2 x 30 mm).
Garen (2 x 30 mm).

40/10

Deco 16

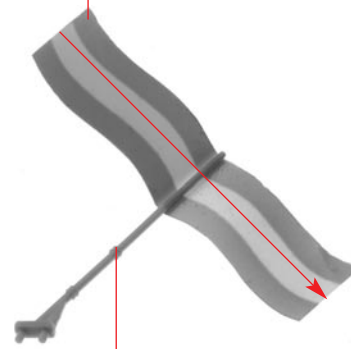

g

Sekundenkleber verwenden.
Use instant modelling cement.
Utilisez la colle rapide.
Gebruik secondenlijm.

h

40/4

i

h

Bemalungshinweis Handlauf, rot, siehe Verpackung.
Painting instructions for handrail, red, see packaging.
Indication pour la peinture Main courante, rouge, voir emballage.
Schilderinstructions voor leuning, rood, zie verpakking.

3/14

3/18

3/20

3/17

3/22

3/3

i

4/17

3/19

3/21

3/10

40/2

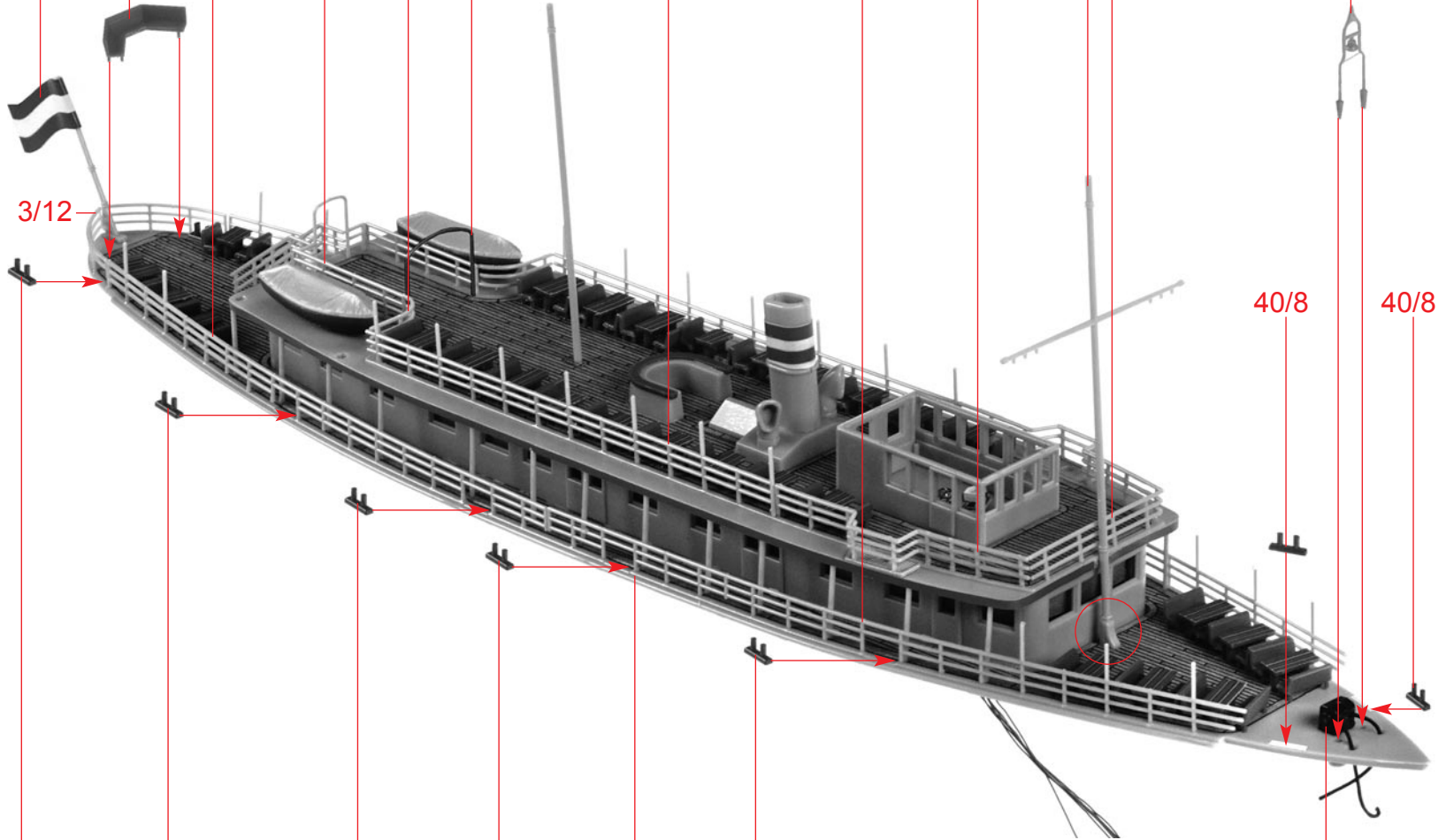

3/12

40/8

40/8

40/8

40/8

40/8

40/8

f

40/8

g

j

Sekundenkleber verwenden.
Use instant modelling cement.
Utilisez la colle rapide.
Gebruik secondenlijm.



Faden (5 mm).
Cord (5 mm).
Aiguillée (5 mm).
Garen (5 mm).

3/24

k 4 x

Deco 13

3/4 40/12

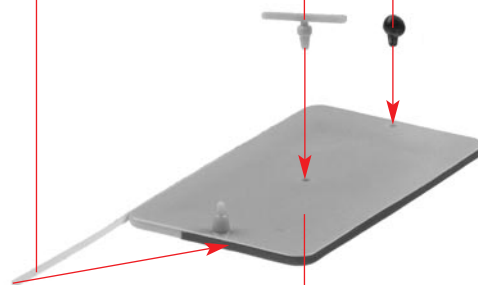

l

2/11

40/5

l

40/5

Papiermaske
Papermask
Masque
Masker **M2**

k

3/9

3/11

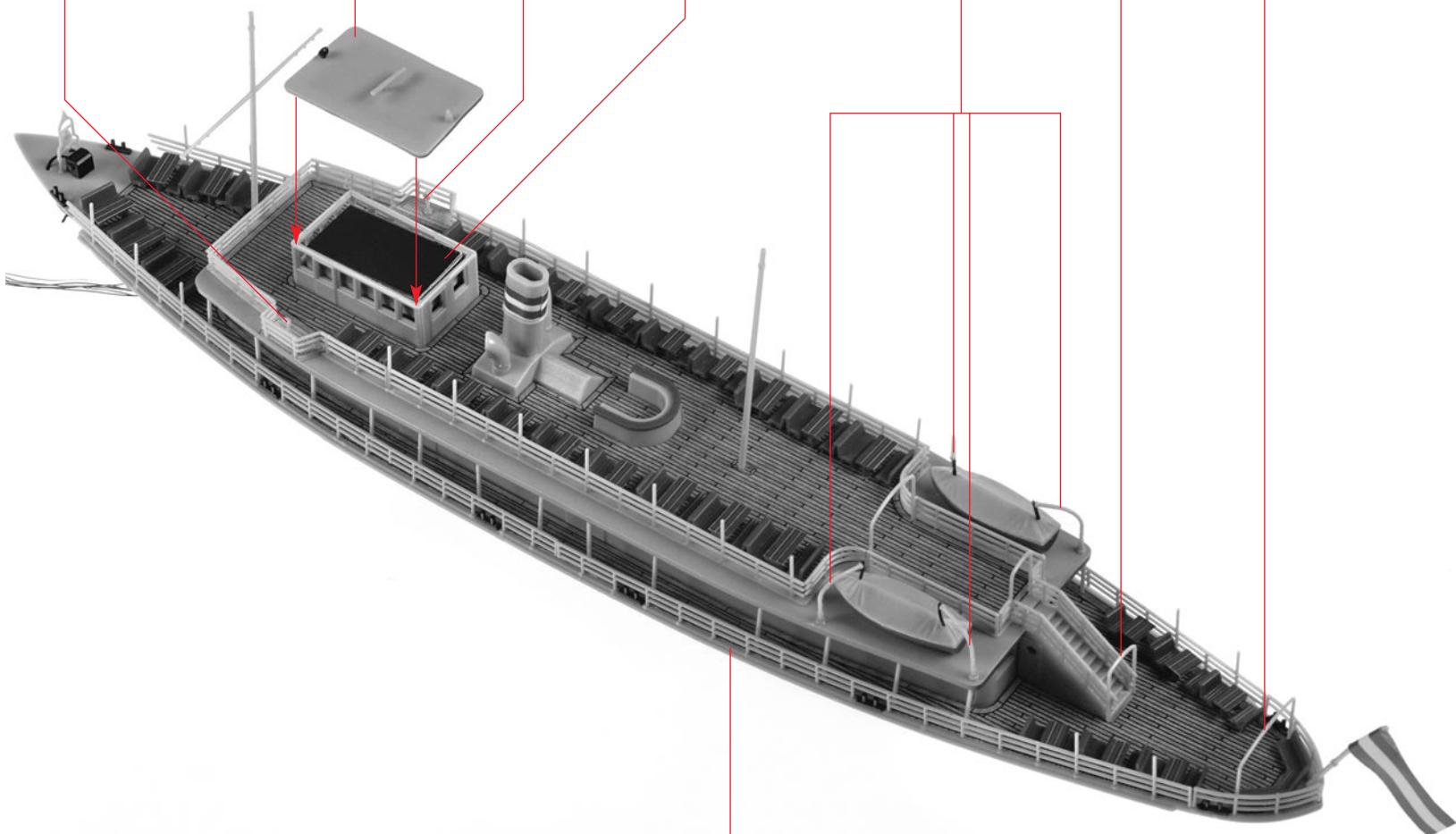

m

j

Faden (120 mm).
Cord (120 mm).
Aiguillée (120 mm).
Garen (120 mm).

Fadenverlauf
Course of thread
Trajet du fil
Verloop van de draden

Faden (280 mm).
Cord (280 mm).
Aiguillée (280 mm).
Garen (280 mm).

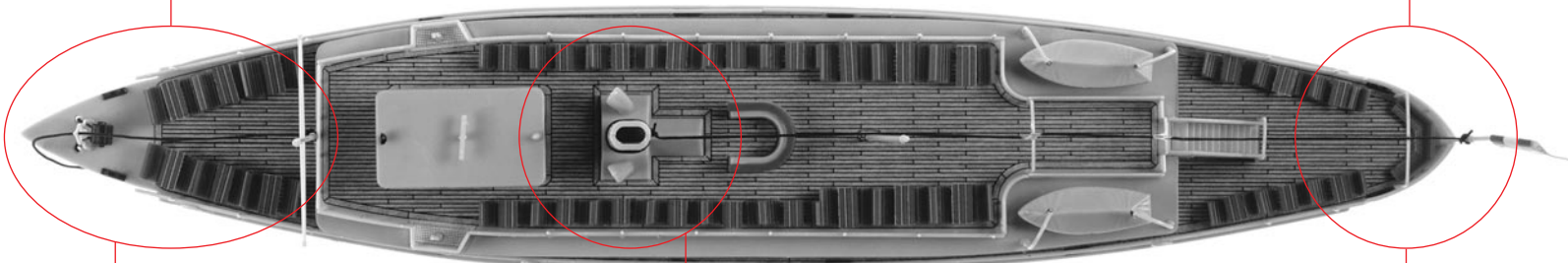

Faden verknoten und den Knoten mit Sekundenkleber fixieren!

Knot the thread and fix the thread with instant cement!

Nouer le fil et renforcer le noeud avec une goutte de colle rapide!

Garen vastknopen en de knoop met secondenlijm fixeren!

Faden verknoten und den Knoten mit Sekundenkleber fixieren!

Knot the thread and fix the thread with instant cement!

Nouer le fil et renforcer le noeud avec une goutte de colle rapide!

Garen vastknopen en de knoop met secondenlijm fixeren!

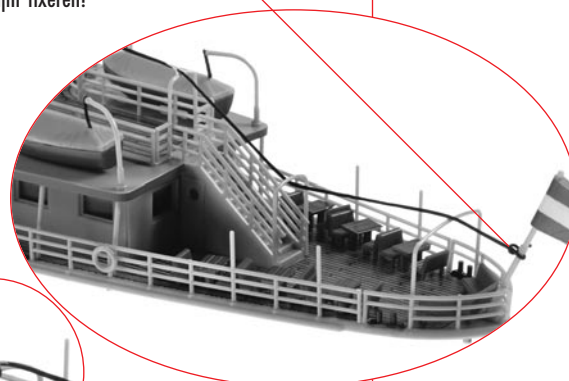
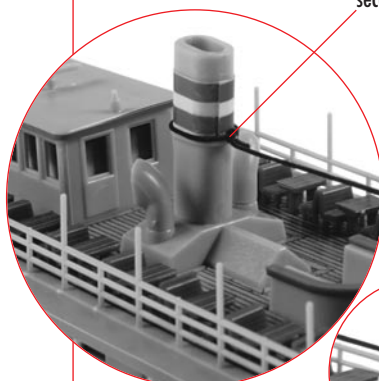
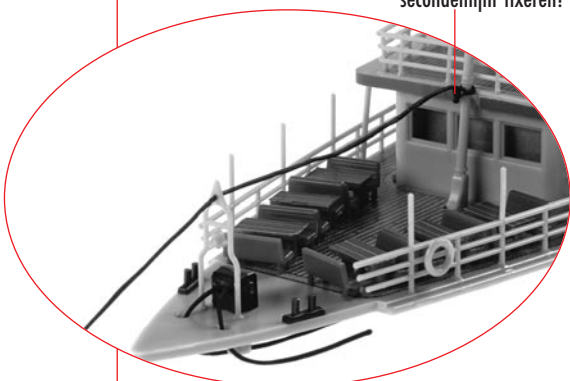

3/25

3/25

3/25

3/25

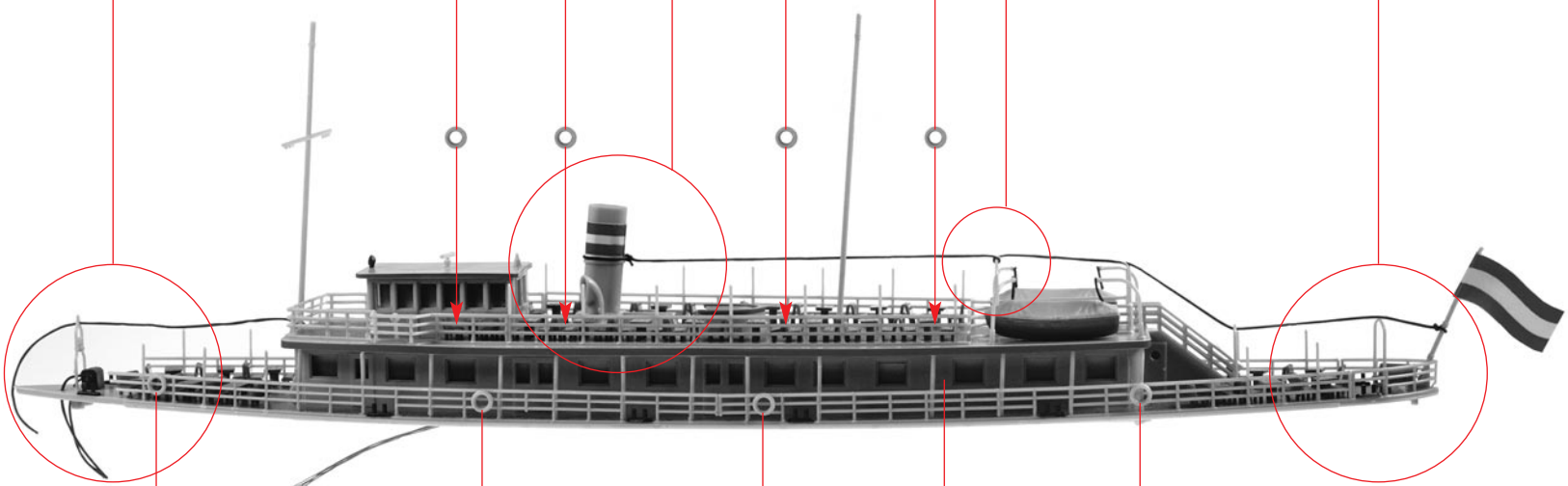

3/25

3/25

3/25



3/25



3/25

Faden verknoten und den Knoten mit Sekundenkleber fixieren!

Knot the thread and fix the thread with instant cement!

Nouer le fil et renforcer le noed avec une goutte de colle rapide!

Garen vastknopen en de knoop met secondenlijm fixeren!

Faden (240 mm).
Cord (240 mm).
Aiguillée (240 mm).
Garen (240 mm).

Deco 8

Deco 6

o

3/25

n

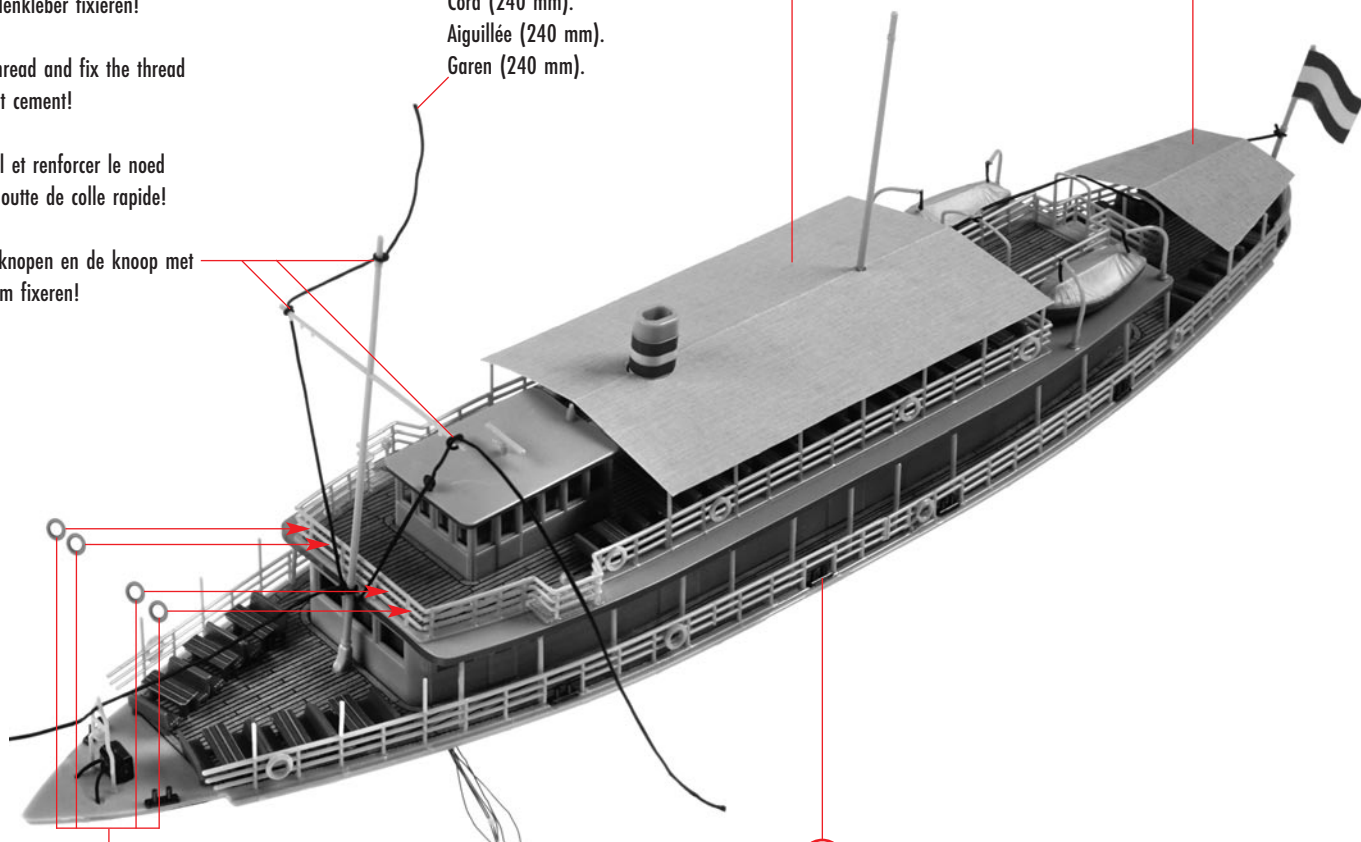

Faden (480 mm).
Cord (480 mm).
Aiguillée (480 mm).
Garen (480 mm).

Faden verknoten und den Knoten mit Sekundenkleber fixieren!

Knot the thread and fix the thread with instant cement!

Nouer le fil et renforcer le noed avec une goutte de colle rapide!

Garen vastknopen en de knoop met secondenlijm fixeren!

Deco 7

p

o

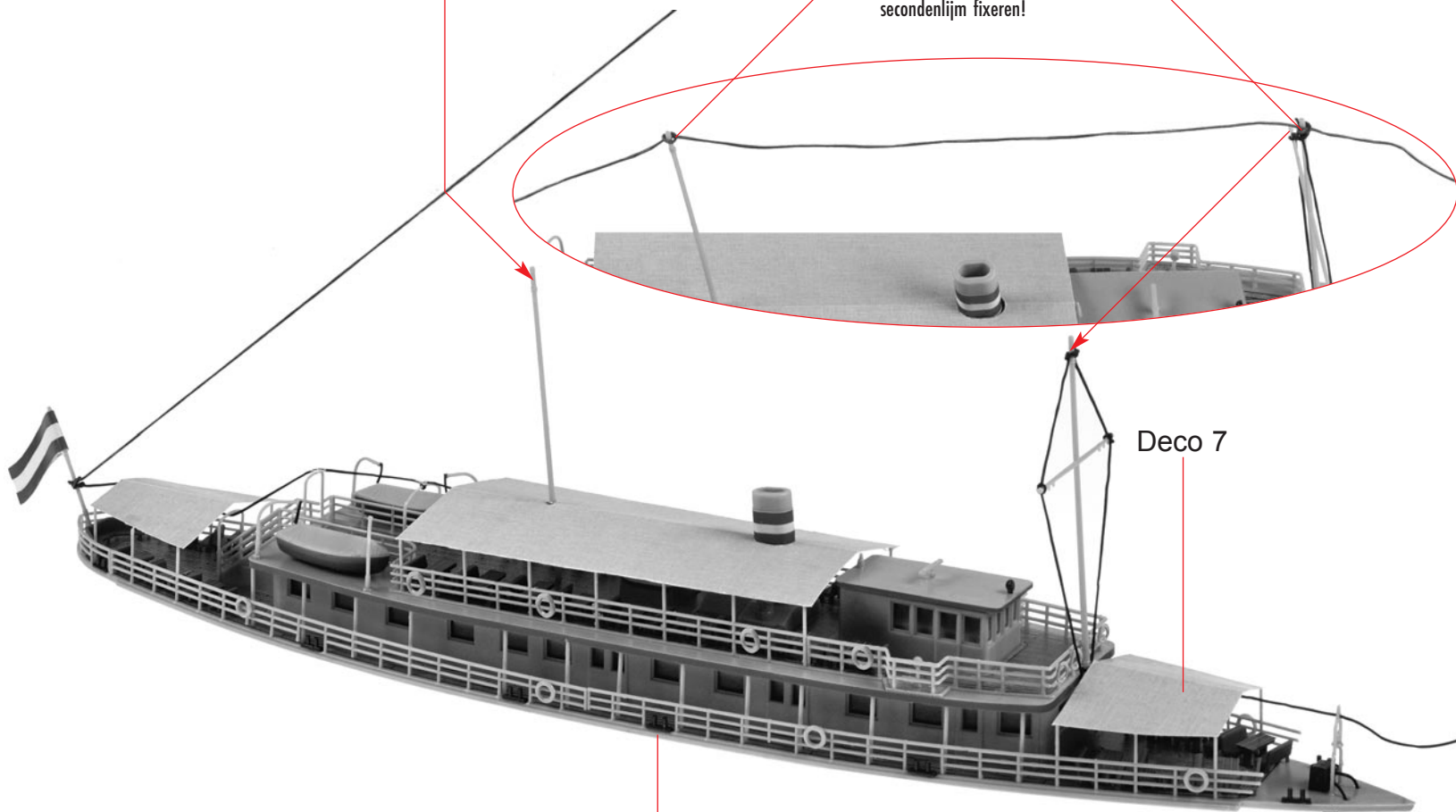

12

Deco 4

Deco 1

Deco 2

Deco 1

Deco 3

Fensterfolie
Window foil
Feuillet transparent
Vensterfolie

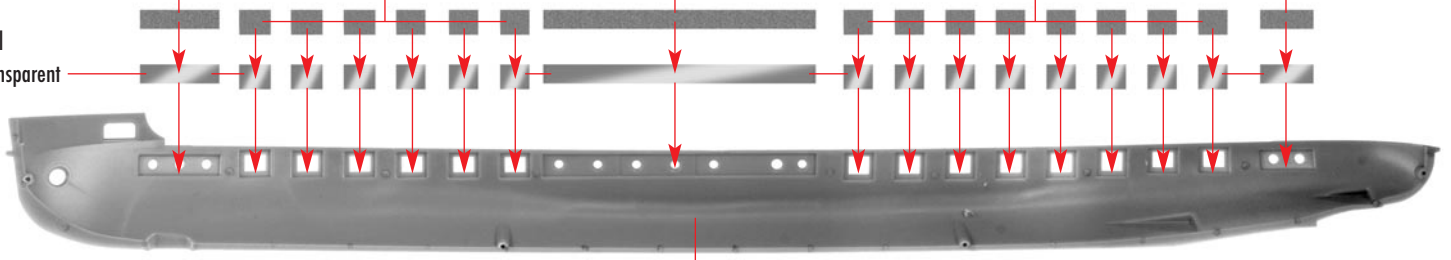

A

1/2

Deco 3

Deco 1

Deco 2

Deco 1

Deco 4

Fensterfolie
Window foil
Feuillet transparent
Vensterfolie

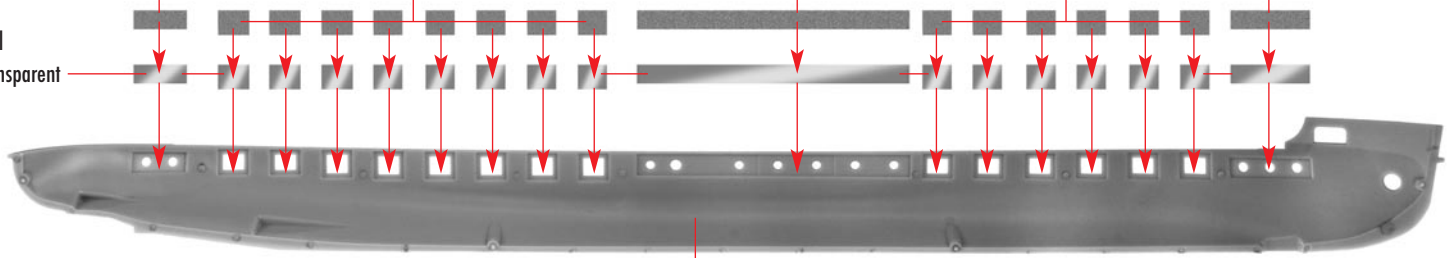

B

1/3

B

Deco 17

40/9

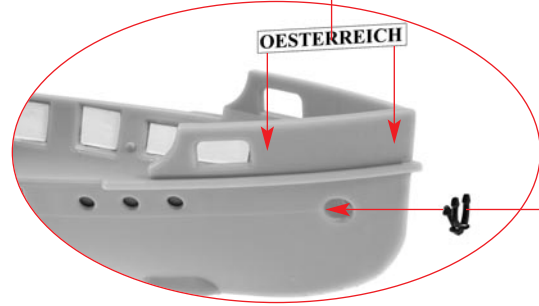

OESTERREICH

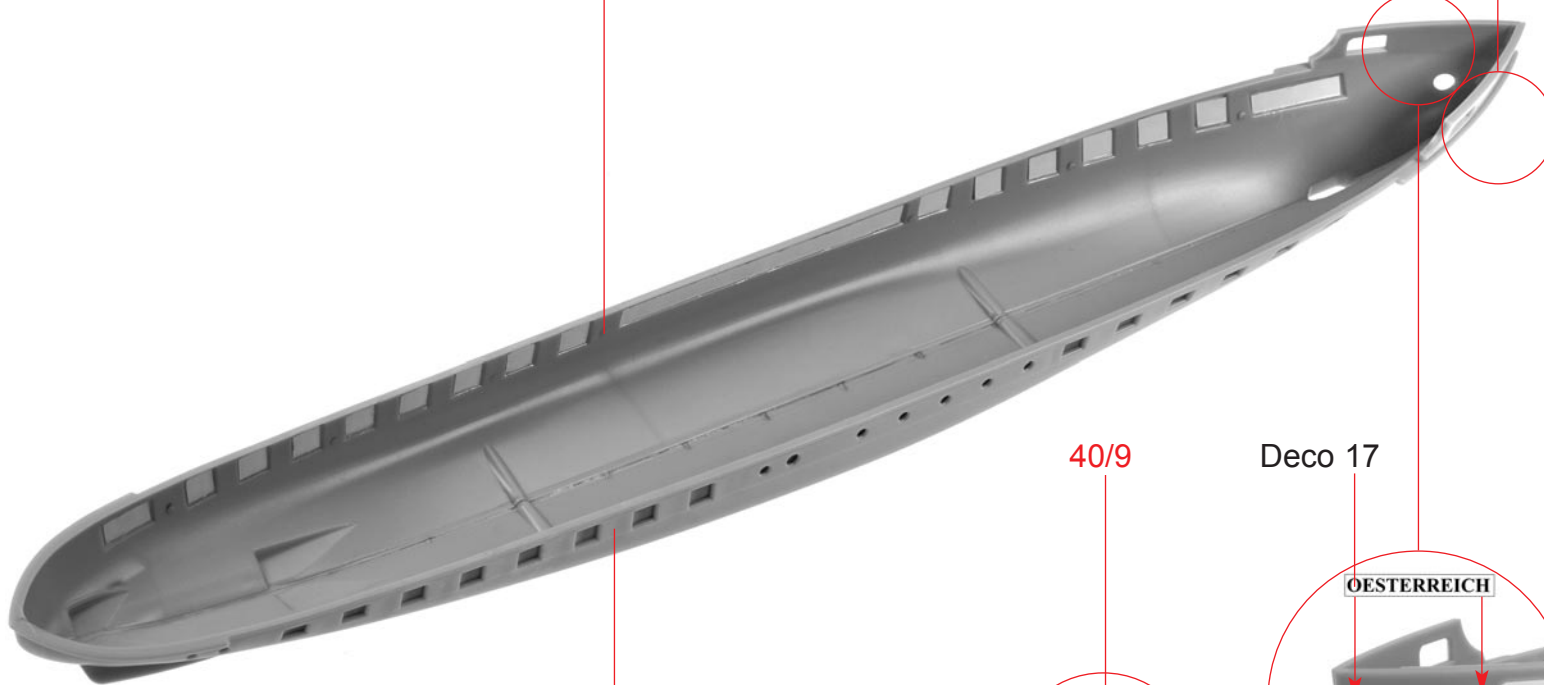

40/9

Deco 17

OESTERREICH



C

A

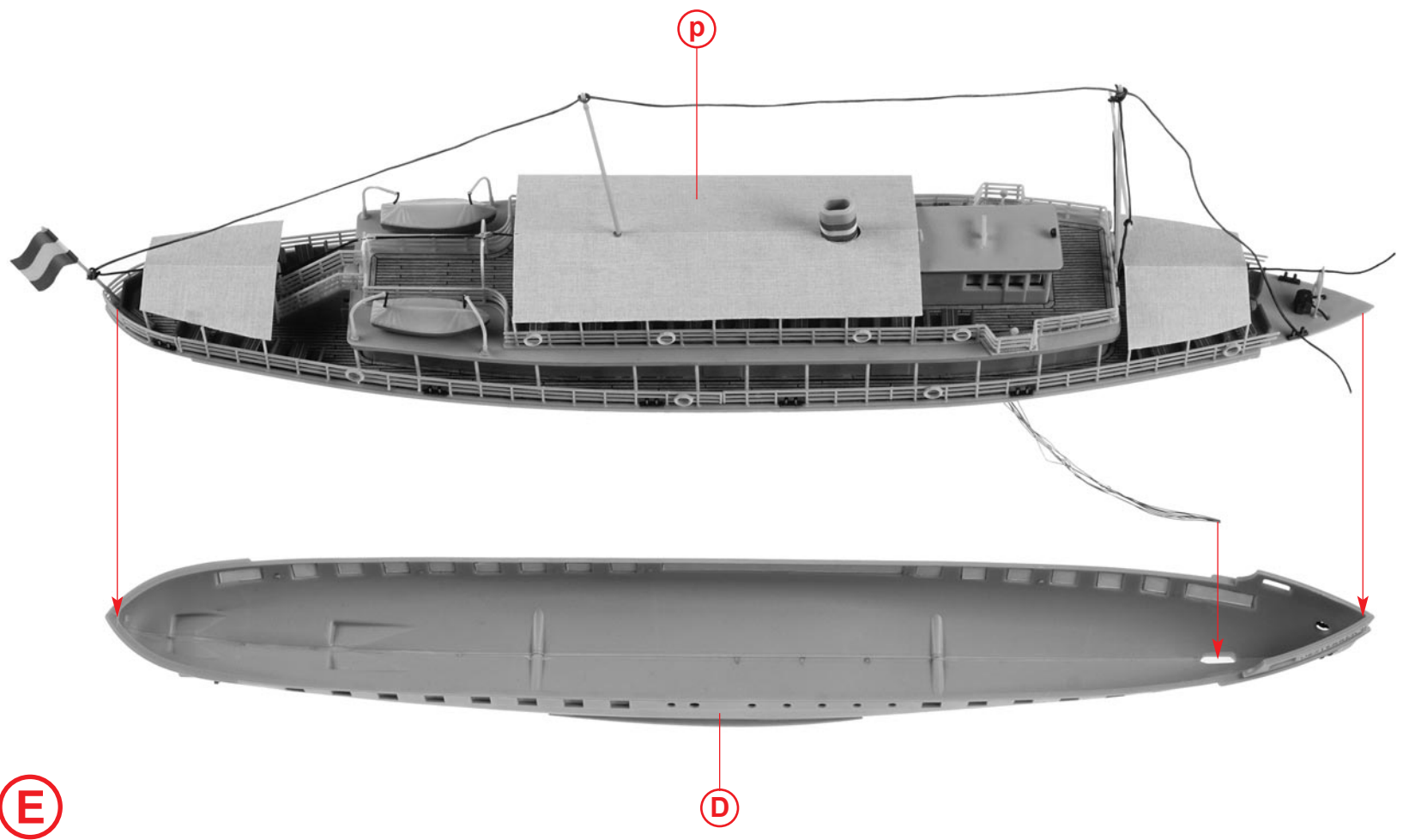
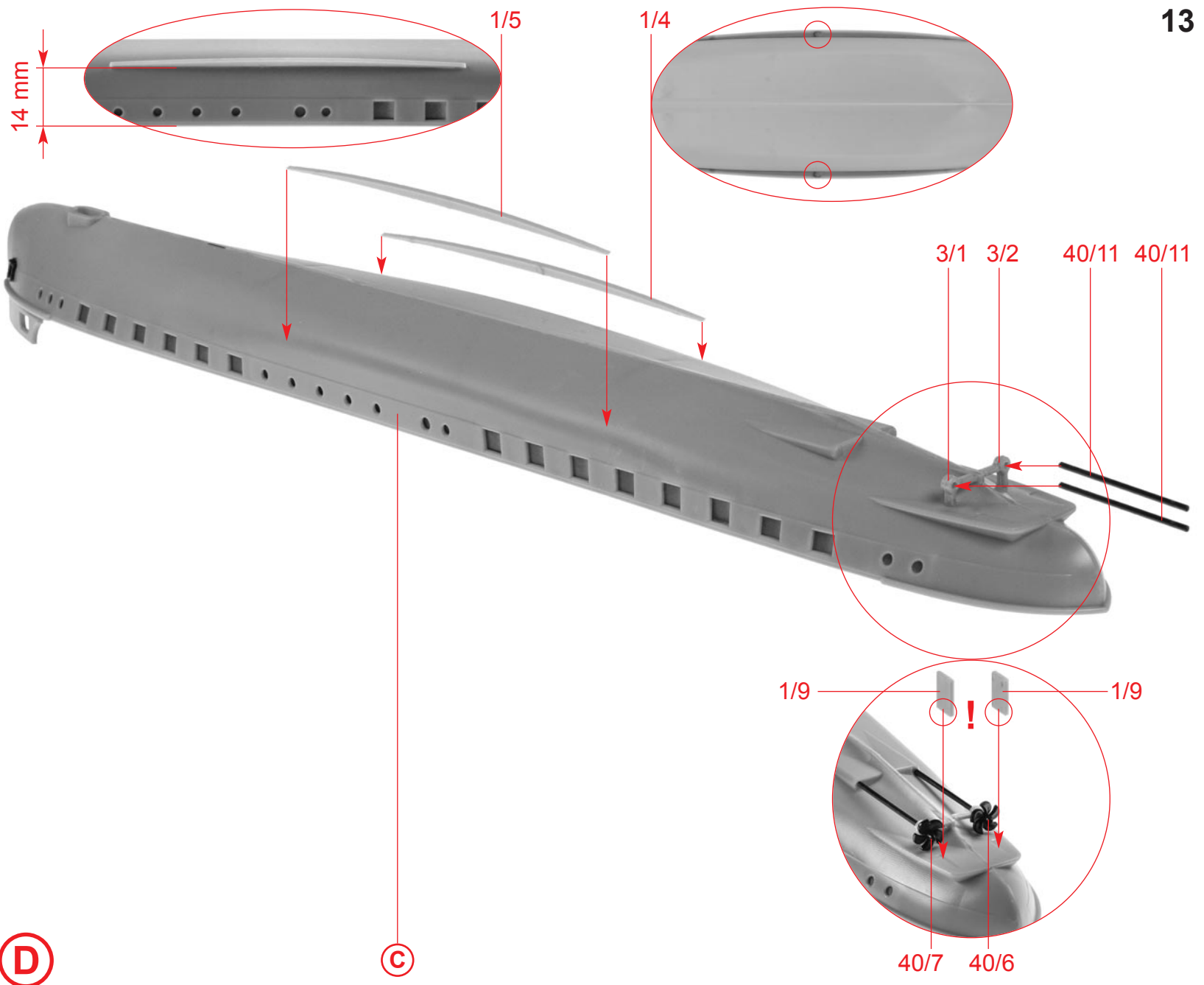

Deco 18

Faden verknoten und den Knoten mit Sekundenkleber fixieren!

Knot the thread and fix the thread with instant cement!

Nouer le fil et renforcer le noeud avec une goutte de colle rapide!

Garen vastknopen en de knoop met secondenlijm fixeren!

40/1

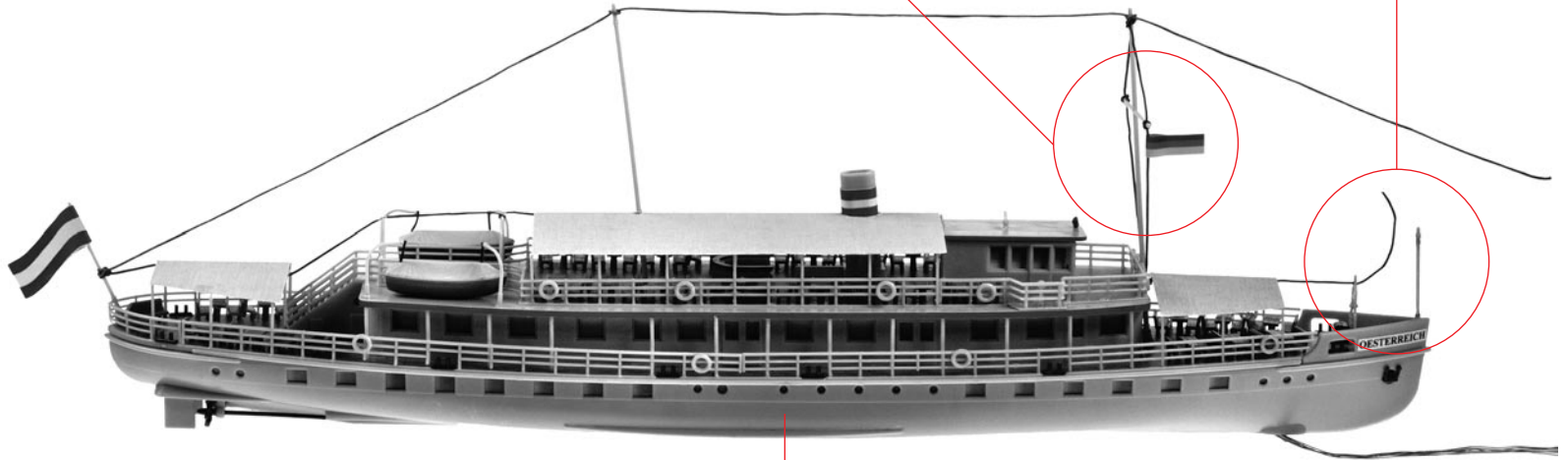
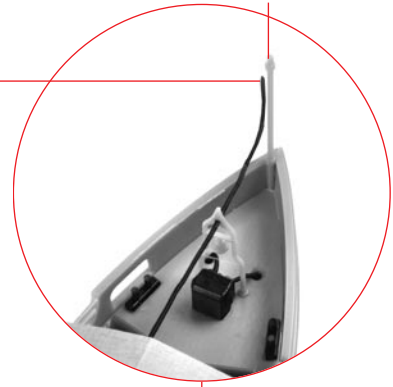
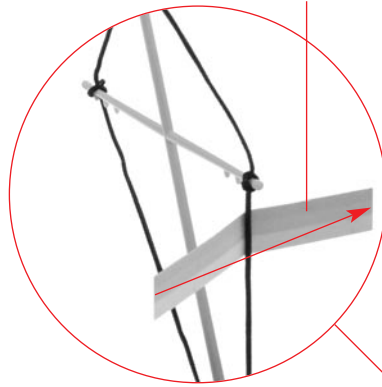

F

E

Bemalungshinweis, rot, siehe Verpackung.
 Painting instruction, red, see packing.
 Instruction de coloration, rouge, voir emballage.
 Schilderadviezen, rood, zie verpakking.

3/26

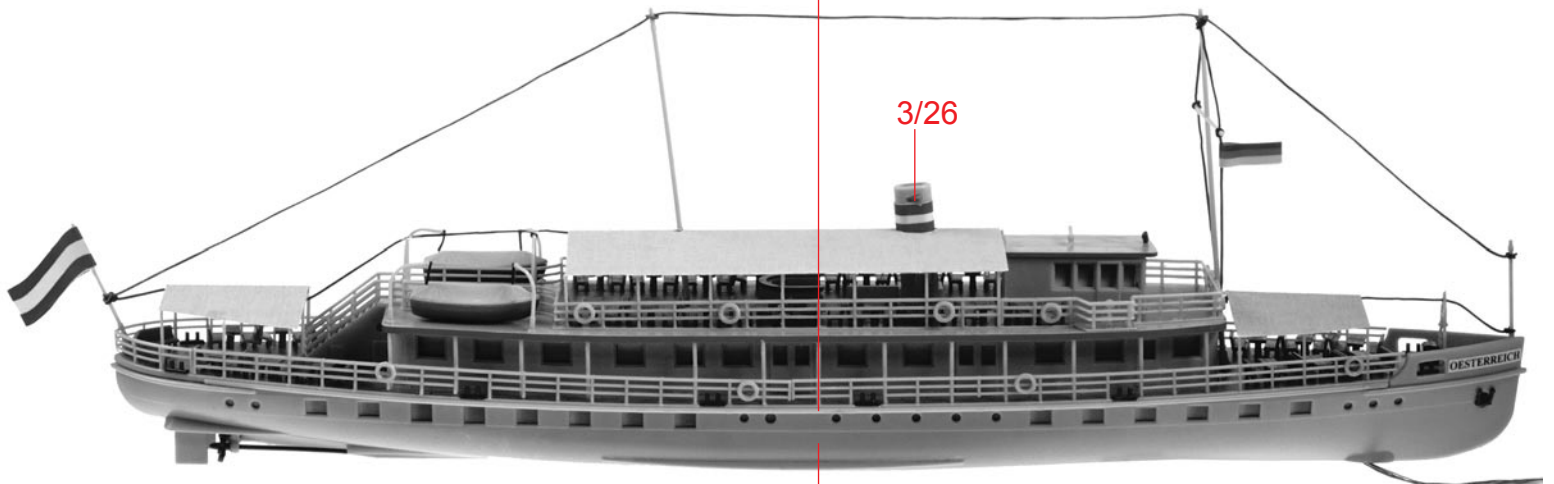

G

F

Bemalungshinweis, rot, siehe Verpackung.
 Painting instruction, red, see packing.
 Instruction de coloration, rouge, voir emballage.
 Schilderadviezen, rood, zie verpakking.

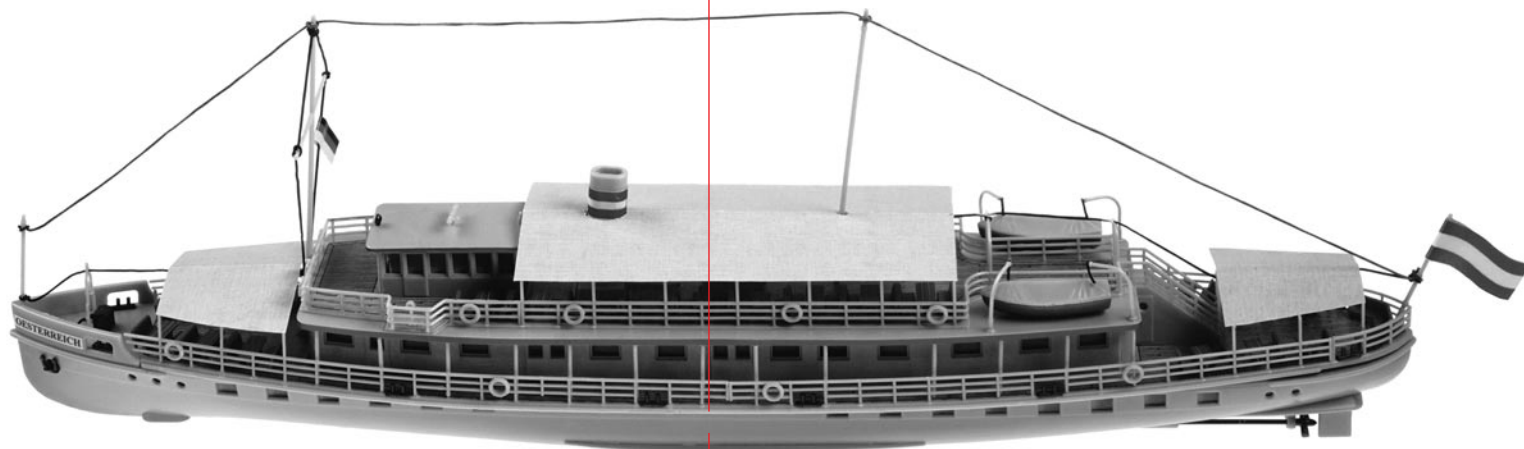

H

G

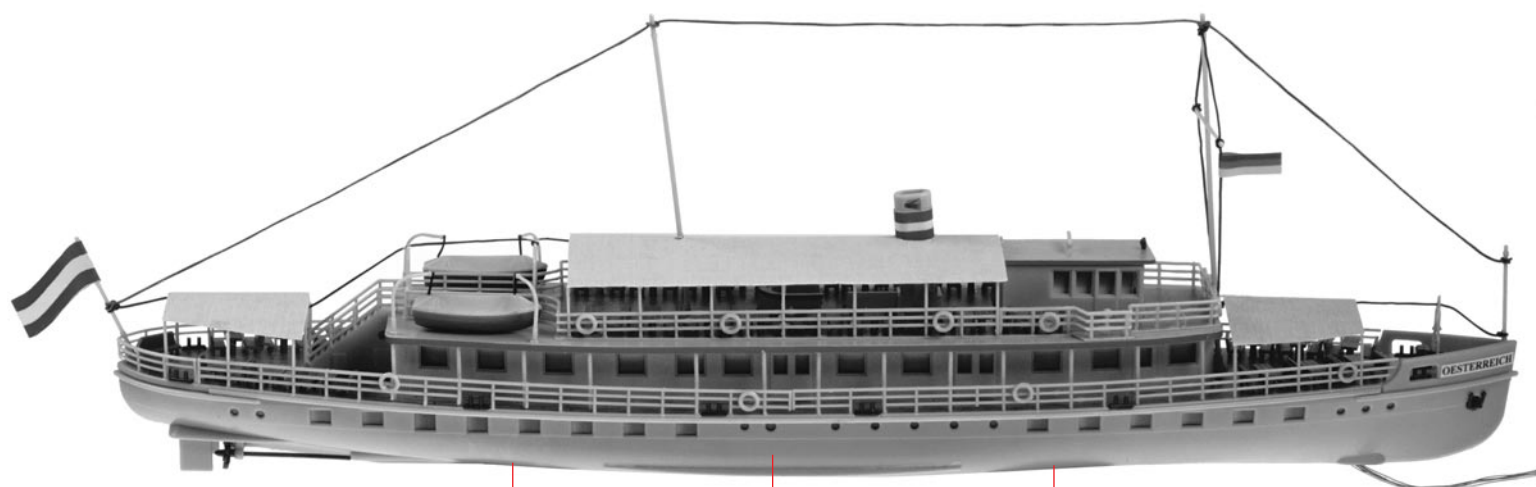

I

40/20

H

40/20

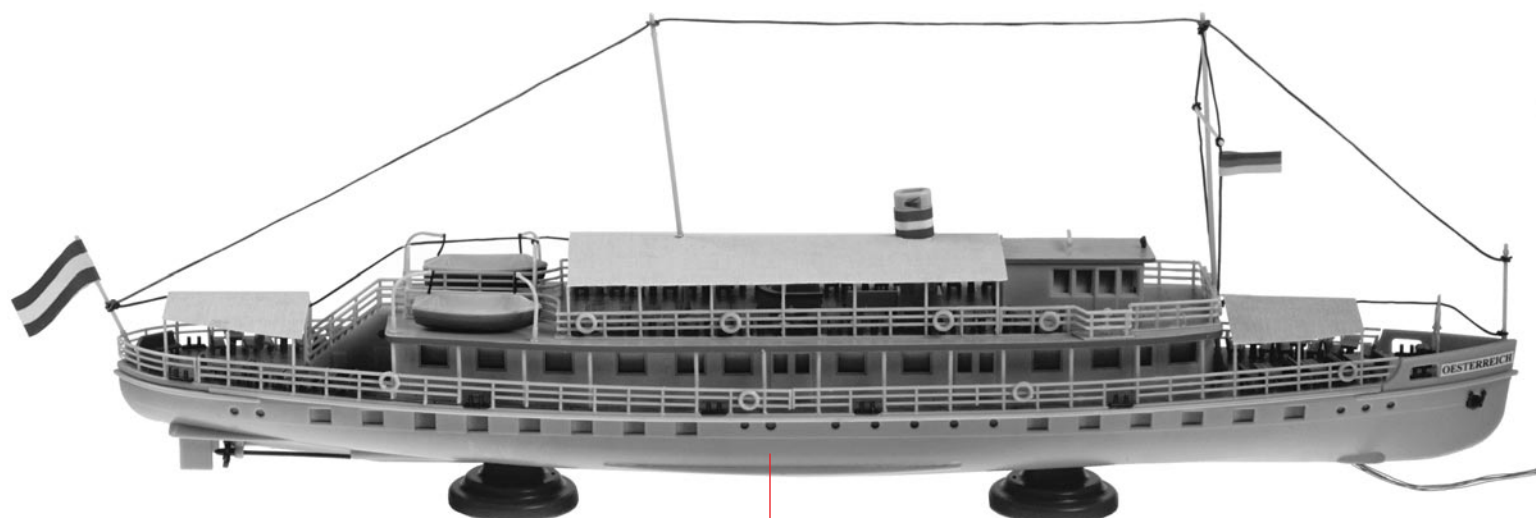

J

I

J

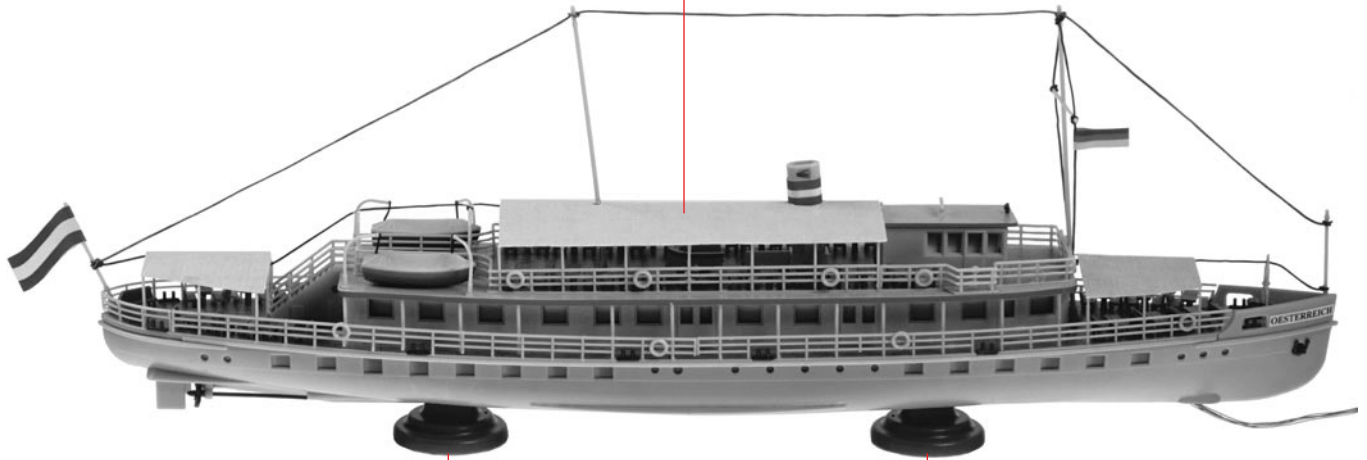

Vallejo Vitrine, 501 x 149 x 146 mm; Art. Nr. 759805, liegt nicht bei
 Vallejo Display case, 501 x 149 x 146 mm; Art. Nr. 759805, not included
 Vallejo Vitrine, 501 x 149 x 146 mm; Art. Nr. 759805, non jointe
 Vallejo Vitrine, 501 x 149 x 146 mm; Art. Nr. 759805, niet bijgevoegd

K