



HO Scale Structure ICE HOUSE AND ICING PLATFORM

933-3049

Thanks for purchasing this Cornerstone Series® kit. All parts are made of styrene plastic, so use only paints and glues which are compatible. Please read these instructions and study the drawings before starting.

For many decades, the ice house and platform were an integral part of larger freight yards. This kit is ideal for any era from the 1900's to the 1970's, when the last ice-cooled cars were retired. The facilities were typically located at the edge of a yard, where the train could be spotted and the engine removed for servicing. Others could be found at remote locations along busy stretches of the line, where a train would need to be serviced.

In operation, both wood and steel reefers could be found alongside the platform. Lease fleet cars were very common and several could be found in the same train.

The platform itself is based on Pacific Fruit Express design, which was constructed at numerous locations and in different sizes.

First, drill the indented holes through one of the #2 wall sections, this now becoming the front wall. Glue the walls (2, 3) together and to the base (1). Now, glue platform loading doors (6) into the holes drilled out of the front wall. Glue the roof pieces (4, 5) on top of the walls. Then, glue the extensions (8, 9) in place, as shown, along with the roofs (7). Glue the roof vents (10, 11, 12) together and then to the roof. Finish assembly of the house by gluing ladders (13) to the side walls.

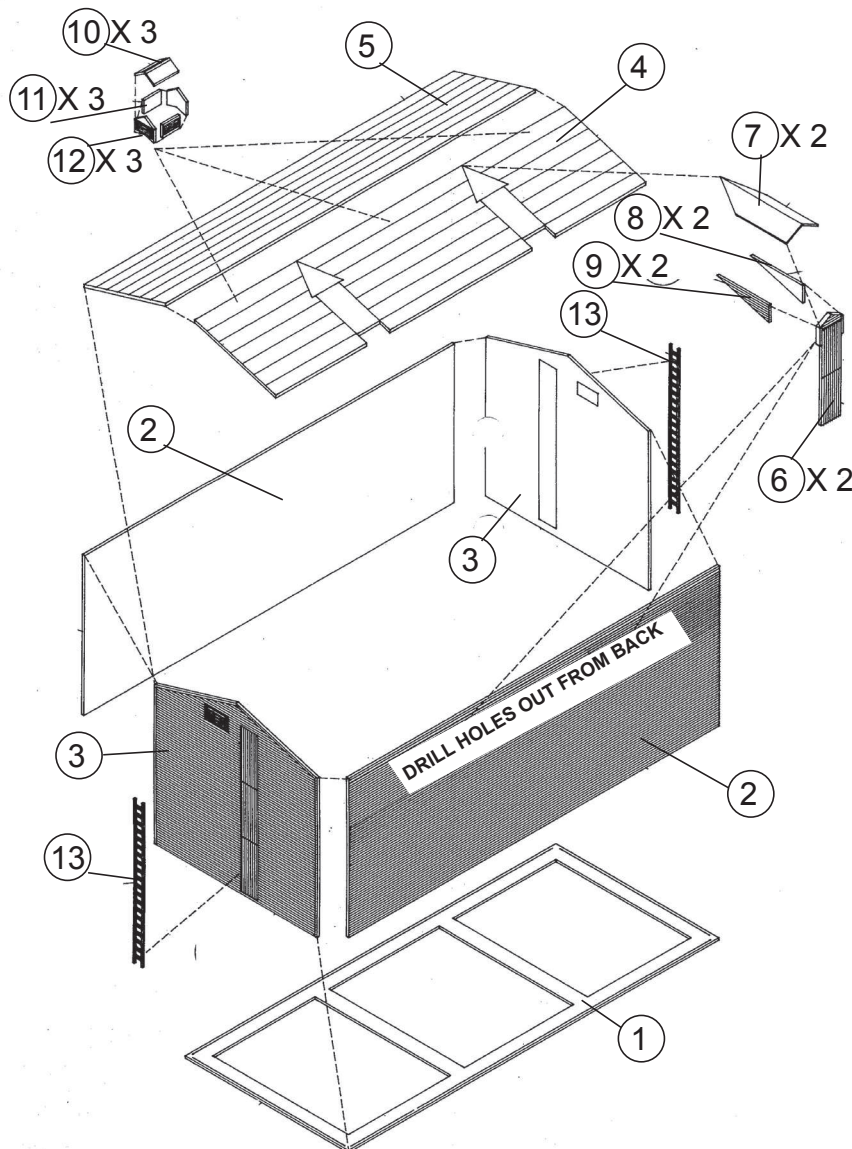

Making sure that the hinge attachment is always facing the same way, glue the vertical frames (15) to the floor (16) by slipping the floor through, at an angle, each frame until it fits into the notches. NOTE: Start at one end and work towards the other. Now, glue vertical frames to holes in base (14). Slightly bend the gangways (17) and snap (do not glue) into the hinge attachments. Next, glue railings (20, 21) in place along with the stairway (22, 23, 24) and the side braces (18).

To build the adjoining platform, first cut off the scribed end of the base (14). Except for not using one of the vertical frames (15) - where the two platforms join - build this one the same as the first. Then, glue the two platforms together at the bases and floor. Glue the roof pieces (19) in place. Snap the remaining gangway (17) in place between the two platforms and glue on the last two side braces (18). Finish by gluing on the railings (20, 21) and the stairway (22, 23, 24).

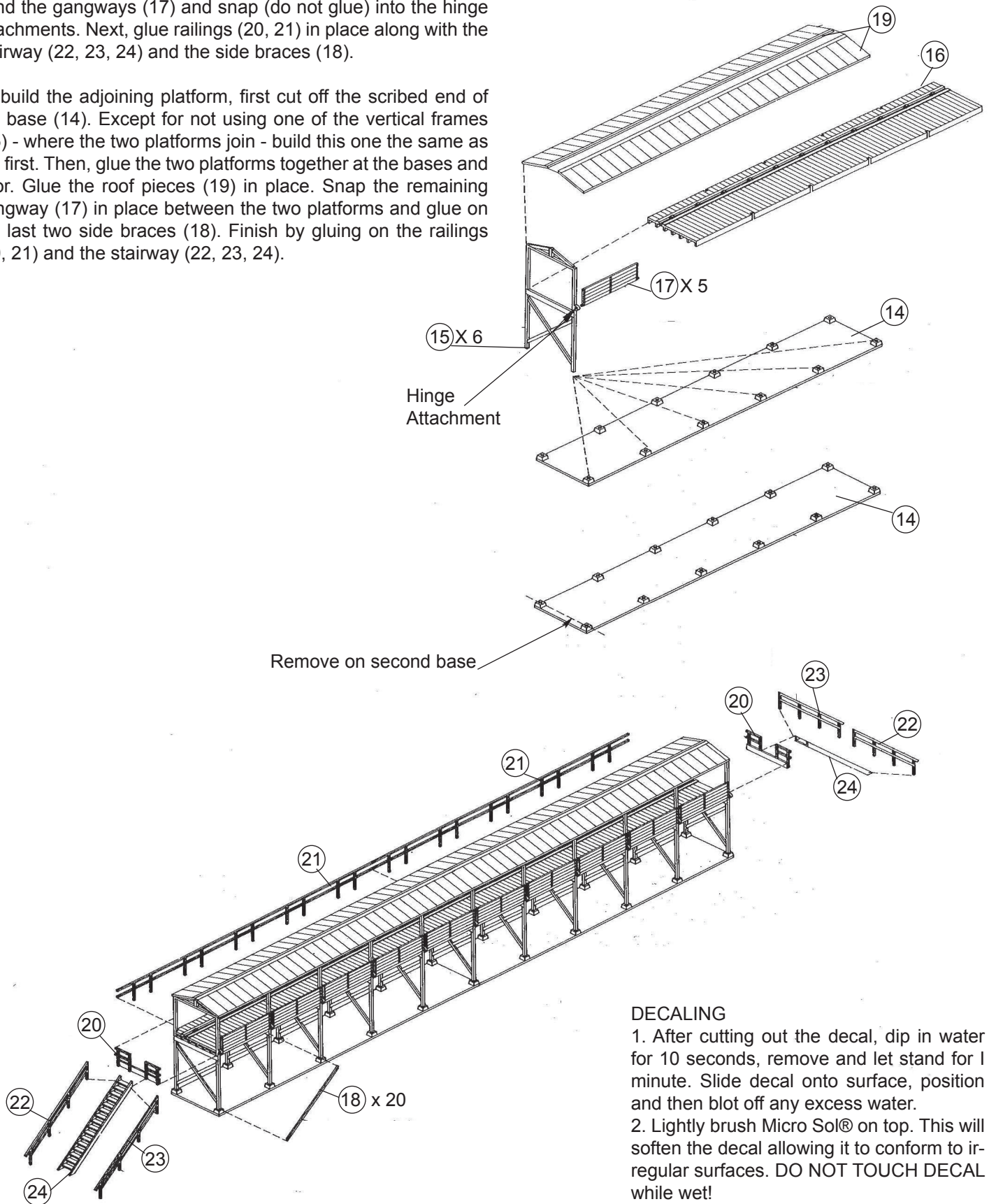

DECALING

1. After cutting out the decal, dip in water for 10 seconds, remove and let stand for 1 minute. Slide decal onto surface, position and then blot off any excess water.
2. Lightly brush Micro Sol® on top. This will soften the decal allowing it to conform to irregular surfaces. DO NOT TOUCH DECAL while wet!
3. When the decal is thoroughly dry, check for any trapped air bubbles. Prick them with the point of a small pin or hobby knife blade and apply more Micro Sol®.