



HO Scale Structure Kit
HERITAGE FURNITURE
933-3164

Thanks for purchasing this Cornerstone Series® kit. Please read all instructions and study the drawings before starting — directions for the interior graphics are printed directly on that sheet. All parts are styrene plastic, so use compatible glue. If you wish to decorate your model, use paints for plastic models. With appropriate details and signs, your finished model fits almost any era.

This special background building lets you use that last little bit of space to create a realistic background for any industrial area. The model can be used on the edge of your benchwork, along a shelf or modular layout and in dioramas. Once installed, it provides a smooth, realistic transition between 3-D foreground scenery and painted or printed backgrounds like Instant Horizons (949-701 series) and Instant Buildings (949-722 series).

The model is right at home on layout from the 1920s to the present day. A steam-era facility can be served by Walthers 50' Double Door Box Cars (932-8350 series) which remained in revenue service on some lines until the 1970s. In a modern setting, virtually any 50' box car can be used to bring in wood products. A typical plant will go through several carloads of lumber every day. Loads are usually delivered by a local wayfreight, which will also pick up any empties.

For more Cornerstone Series® kits as well as additional details to complete your scene, see your hobby shop, check out the latest Walthers HO Model Railroad Reference Book and our Website at waltherscornerstone.com.

Please Note: Before starting construction, you'll need to decide how you want to assemble your model. While it can be built stock, it is designed for easy customizing. It can be built 4-3/4" (12.1cm) or 2-1/2" (6.4cm) deep. You can also assemble it angling it to the left or right. Follow the cutting directions for the base, roof and sides for the version you decide to build.

- A. For a 4-3/4" (12.1cm) deep structure, no cutting is needed.
- B. For a 2-1/2" (6.4cm) deep structure, cut both the base (1) and the roof (31) at the first horizontal groove underneath those parts. Discard the portion with the "x" grooves. Then cut the side walls (3,4), following the groove on the inside and discard the portion with the freight door.
- C. To build an angled structure, use the angled grooves to cut both the base (1) and roof(31) on either a left or right angle, depending on your choice. Cut the wall section that meets the short side of the base and roof using the groove on the inside of the wall. Discard the portion with the freight door. The other wall will be used as is and requires no cutting.

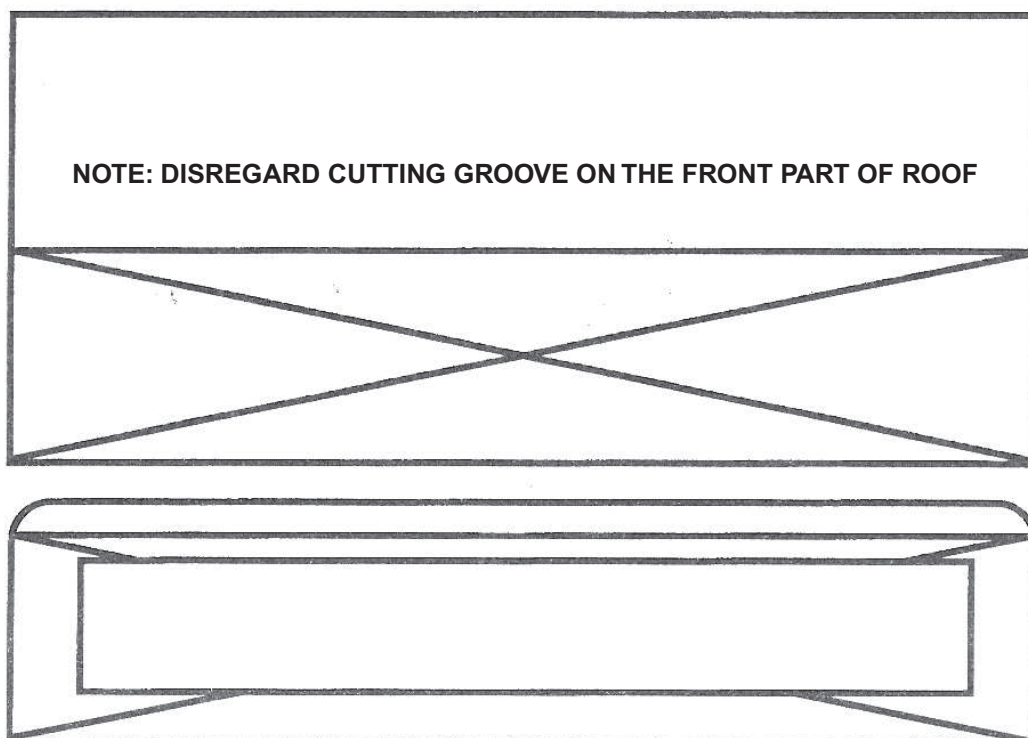

1. Glue the windows (36) into the openings in the back of the front wall (2).
2. Glue the small pillar backs (51) in place, on top, to the back of the front wall.
3. Glue the large pillar backs (7) in place, on the bottom, to the back of the front wall.
4. Glue the "glass" (44) to the back of the windows.
5. Glue the windows (36) into the openings in the back of the side walls (3,4).
6. Glue the small pillar backs (51) in place, on top, to the back of the side walls.
7. Glue the freight door (39) into the openings in the back of the side walls.

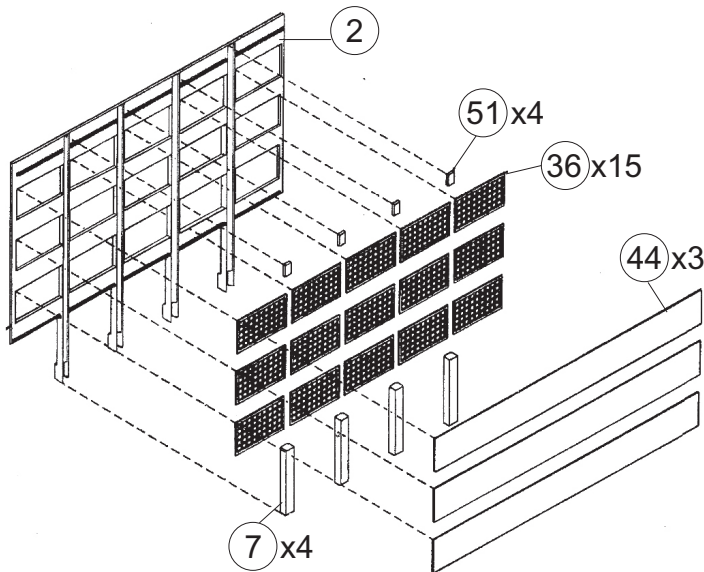

Cutting Groove

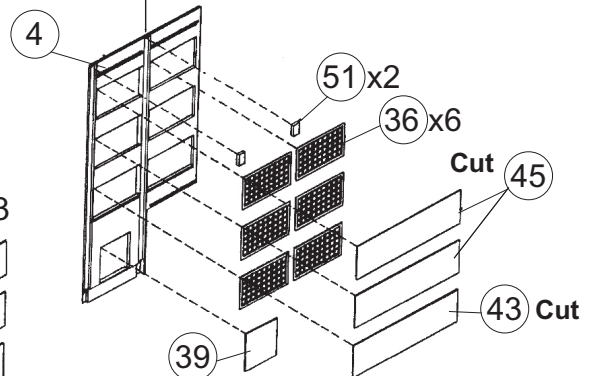

Cutting Groove

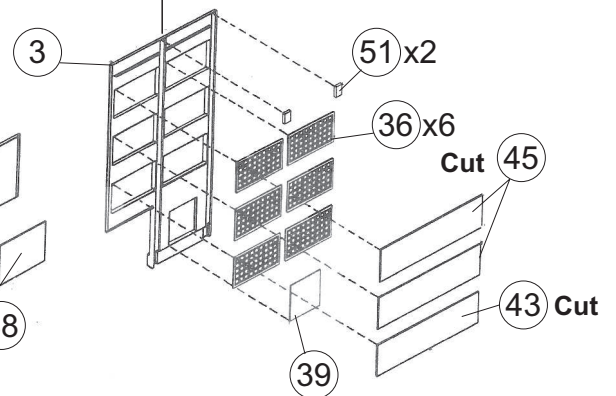

8. Cut the "glass" (43, 45) pieces along the ridges on the back side for use on the side walls. Then glue them in place on the backs of the windows as shown.
9. Glue the large freight doors (38) in place on the back of wall #8.

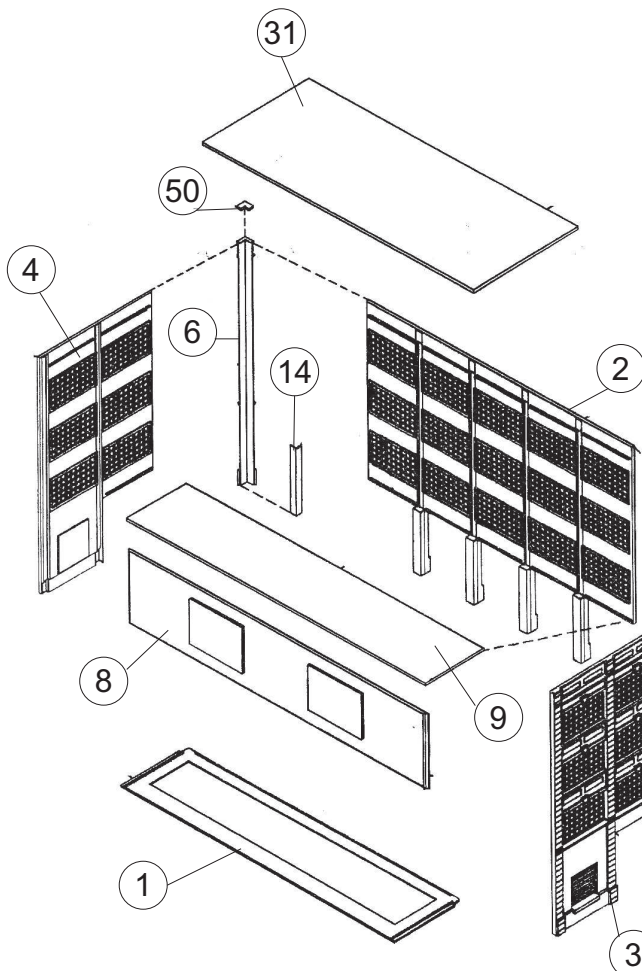
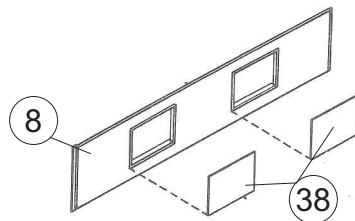

10. Glue the walls (2, 3, 4, 8) together and walls #'s 3, 4 and 8 to the base (1).
11. Glue the lower roof (9) in place.
12. Glue the end pilasters (6) to the corners of the walls and glue the inner pieces (14) to the backs of #6.
13. Glue the main roof (31) on top of the ridges on the backs of the walls.
14. Glue the corner caps (50) on top as shown.

DECALING

1. After cutting out the decal, dip in water for 10 seconds, remove and let stand for 1 minute. Slide decal onto surface, position and then blot off any excess water.
2. Lightly brush Micro Sol® on top. This will soften the decal allowing it to conform to irregular surfaces. DO NOT TOUCH DECAL while wet!
3. When the decal is thoroughly dry, check for any trapped air bubbles. Prick them with the point of a small pin or hobby knife blade and apply more Micro Sol®.