



# HO Structure Kit GROCERY DISTRIBUTOR

933-3760

Thanks for purchasing this Cornerstone Series® kit. Please read these instructions and study the drawings before starting. All parts are styrene, so use compatible glue and paint to assemble your model.

The modern grocery store is quite an achievement, with 40,000 or more items available at all times. But getting products on those shelves is a big job, requiring support from a grocery distributor. Over the years, two major types developed; wholesale suppliers serving smaller chains and independent buyers, and company-owned distribution centers. Both purchase larger quantities from importers and brokers, or direct from food producers and manufacturers. Half of all products coming in are perishables like meats and dairy products, nonperishable foods and beverages make up 30% and various other products from cleaning supplies to dog toys make up the last 20%. But most grocery stores don't have a lot of floor space, relying heavily on distributors for frequent shipments. This requires distributors to be able to receive, sort and reload products from both railroads and trucks in a very short time. As such, larger grocery chains will have several distribution centers, each supplying the firm's stores (sometimes operated under different names, but owned by the same company) within a radius of about 250 miles (420k). Your new model can easily be one of the busiest rail-served industries on your layout. Ask your local hobby shop, or visit [waltherscornerstone.com](http://waltherscornerstone.com) for additional details, such as delivery trucks, forklifts and workers to complete the scene.

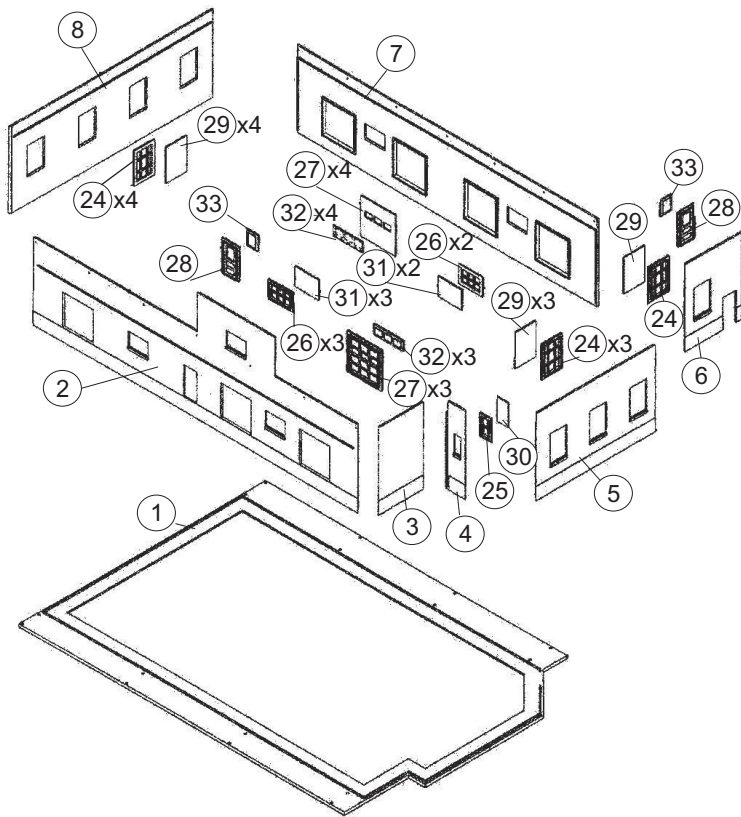

1. Glue windows (24, 25, 26) and doors (27, 28) into the openings in the back of their respective walls (2, 4, 5, 6, 7, 8) as shown.
2. Glue the window "glass" (29, 30, 31, 32, 33) to the backs of doors and windows.
3. Glue walls (2, 3, 4, 5, 6, 7, 8) together and to the base (1). Note: Wall #6 follows the angle of the base.

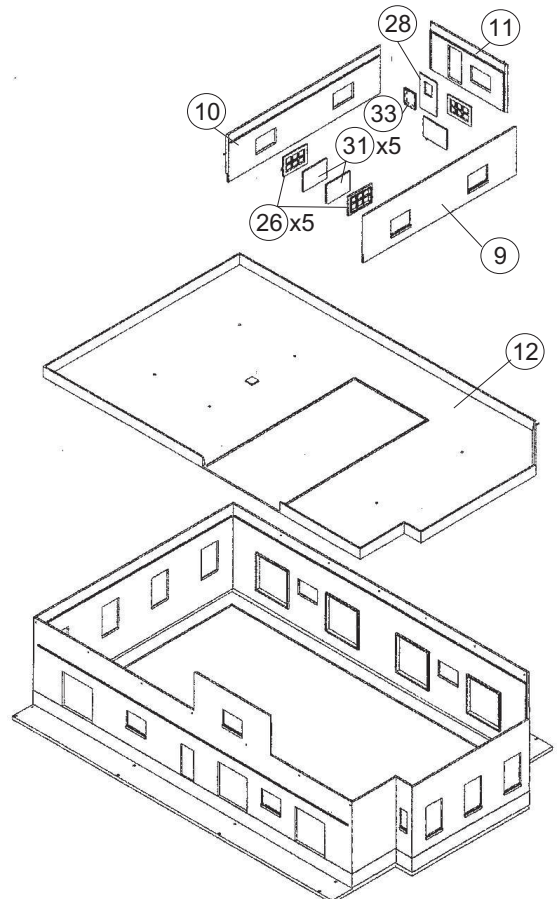

4. Glue the windows (26) and door (28) into the openings in the back of their respective walls (9, 10, 11)
5. Glue the window "glass" (31, 33) in place as shown.
6. Glue the roof (12) inside the walls, using the ridges to position.
7. Glue walls (9, 10, 11) together and in place on the roof.

8. Glue the platforms (16,17) into the holes in the base as illustrated.
9. Glue the steps (35) in position.
10. Glue the small roof (13) inside the walls, using the ridges on the inside of the walls to position.
11. Glue the small canopy (18) and the large canopy (19) in place as illustrated. Use the ridges on the appropriate walls to position.
12. Glue the short support rods (20) into holes in #18 and adjacent wall. Glue the long support rods (21) into the holes in #19 and that adjacent wall.
13. Glue the chimney (22, 23) together and then to the large roof over the ridges.
14. Glue the vents (34) into the holes on both roofs.

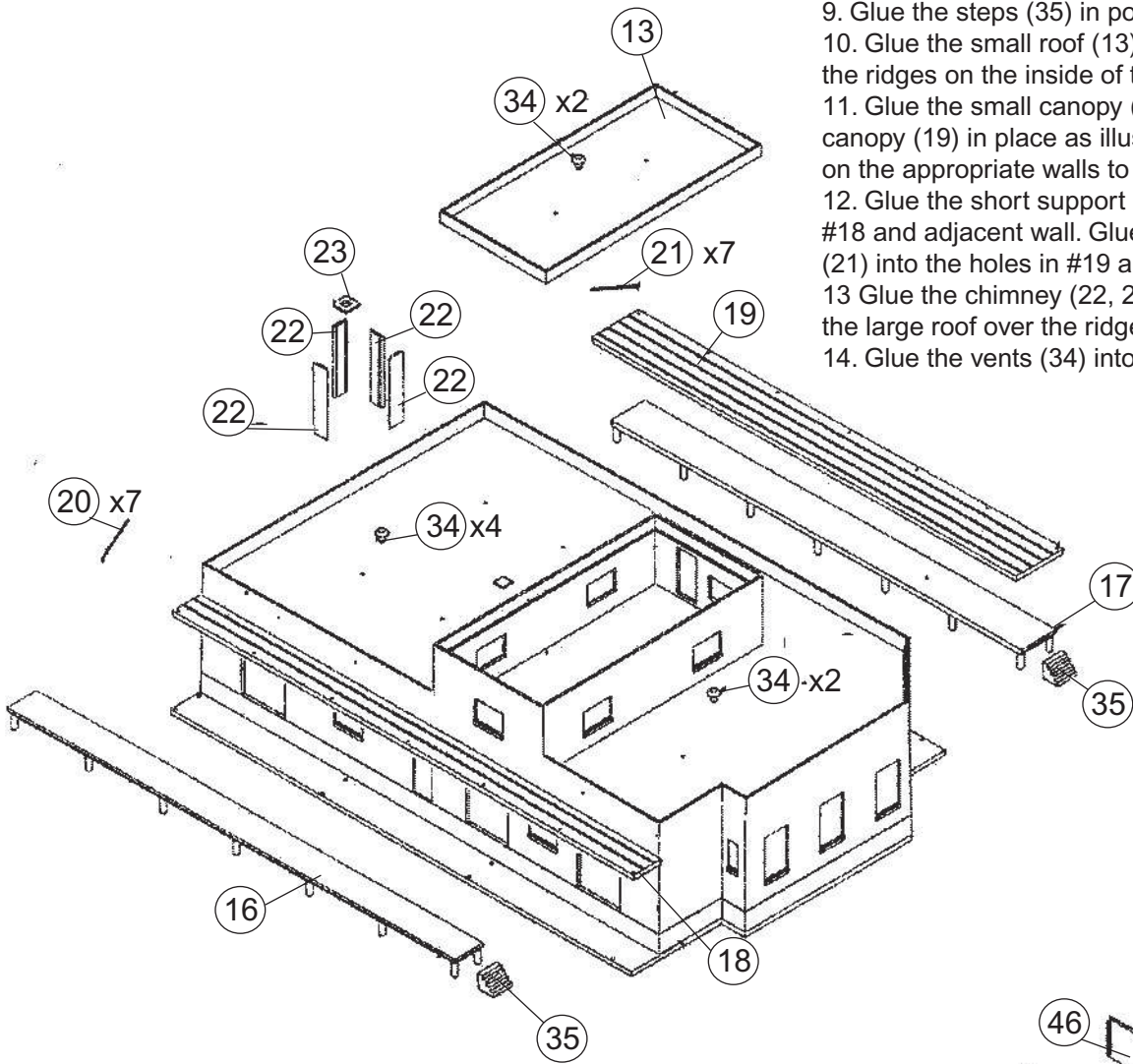

15. Glue the wall caps (36,37,38,39,40,41,42,43,44,45) on top of the walls as illustrated.
16. Glue the sign supports (47) to the back of the sign (46) and place, or glue, the completed sign on the large or small roof.

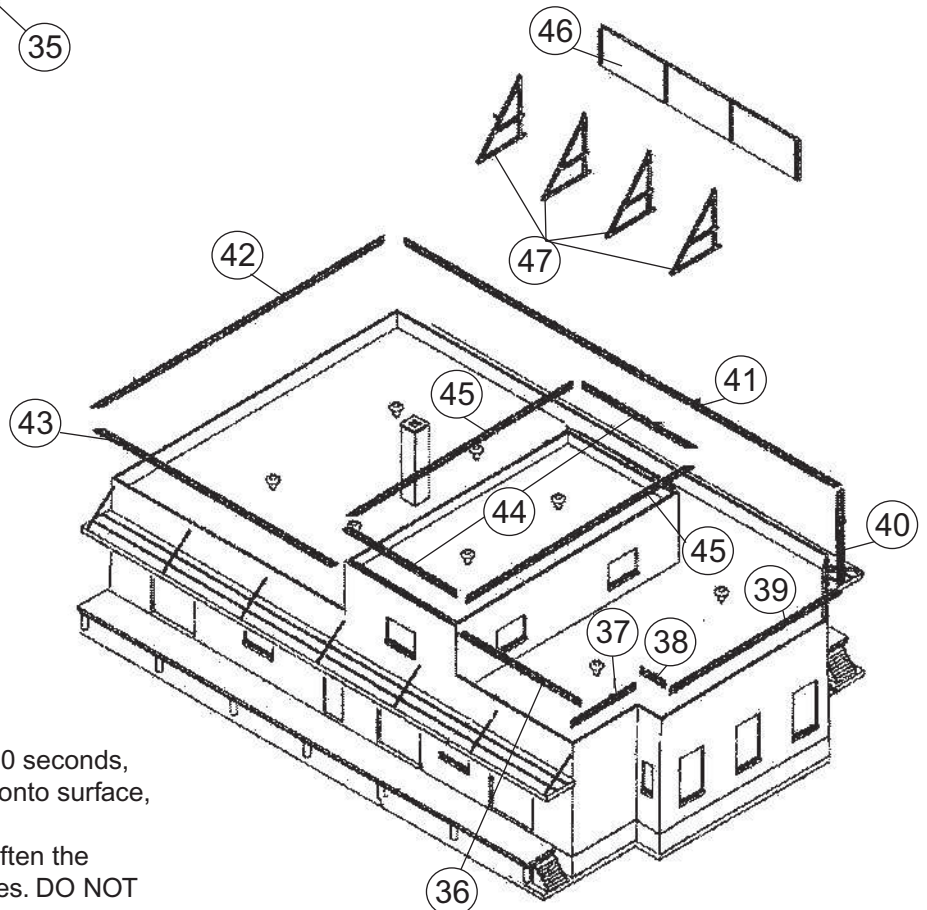

## DECALING

1. After cutting out the decal, dip in water for 10 seconds, remove and let stand for 1 minute. Slide decal onto surface, position and then blot off any excess water.
2. Lightly brush Micro Sol® on top. This will soften the decal allowing it to conform to irregular surfaces. **DO NOT TOUCH DECAL** while wet!
3. When the decal is thoroughly dry, check for any trapped air bubbles. Prick them with the point of a small pin or hobby knife blade and apply more Micro Sol®.