

Mörser Karl-Gerät 040/041 on railway transport carrier

1:35 Scale

德国“卡尔”(60cm)&(54cm)自行迫击炮铁路运输型

READ BEFORE ASSEMBLY

- Study and understand these instructions thoroughly before beginning assembly. Make sure all parts are included by comparing them to those shown on pages 2 & 3 of these instructions. Remove parts from sprues as needed, and trim excess with a hobby knife. Be careful not to lose small parts. Remove photo-etch parts from sprue as needed using a hobby knife or photo etch cutter. Apply cement to photo etch parts as shown on instructions. Applying too much cement will restrict the operation of these

movable parts. Apply cement carefully! Removed photo etch parts can have sharp edges. Take care when handling these to avoid injury. Apply decals to necessary parts prior to assembly.

- Additional tools recommended(not included):Sprue cutter, Long nose pliers, hobby knife, file, tweezers, pin vise, scissors, cement, sandpaper, soft cloth, glue and paint.
- Keep all parts out of reach of children, as they pose a choking hazard.
- Discard all unnecessary bags and sprues when model is completed to avoid accidental injury.

装配之前仔细阅读

- 小心用模型锉刀锉平所有零件表面的注射浇口。
- 小心用刀片切下蚀刻片零件，不要遗失小零件。
- 用强力快干胶水粘合蚀刻片零件和金属轴。过量的快干胶水使用可能导致可动零件会粘住，小心涂胶。
- 取蚀刻片时应特别注意安全，防止利边划伤手指。
- 某些零件表面需贴上水贴纸，请选择在装配的同时进行。
- 推荐模型工具(自备)：胶水、水口剪刀、长咀钳、刀片、锉刀、镊子钳、钻、剪刀、瞬间快干胶。
- 软布同砂纸同时也应该是必备工具。
- 请使用塑料胶水和油漆，模型内不含。
- 谨防小孩吸吮塑料零件，或者将塑料袋套在头上，制作时应将套材远离小孩接触。

水贴纸的使用:

1. 从水贴纸上剪下印花;
2. 将印花放入温水中浸10秒, 然后放在干净布上。
3. 拿着印花纸板将印花移到模型上;
4. 手指蘸水将印花移到适当的位置;
5. 用软布轻压印花直至水干, 气泡消失。

DECAL APPLICATION

1. Cut off decal from sheet.
2. Dip the decal in tepid water 40° C for about 10 sec. and place on a clean cloth.
3. Hold the backing sheet edge and slide decal onto the model.
4. Move decal into position by wetting decal with finger.
5. Press decal gently down with a soft cloth until excess water and air bubbles are gone.



cyanoacrylate glue
使用强力胶



weight
配重



make hole
钻孔



cut / remove
切除



option
选择



no cement
不涂胶水



decal
贴纸



bend
弯曲



file / sand
锉平

部品图 Parts

A x 2

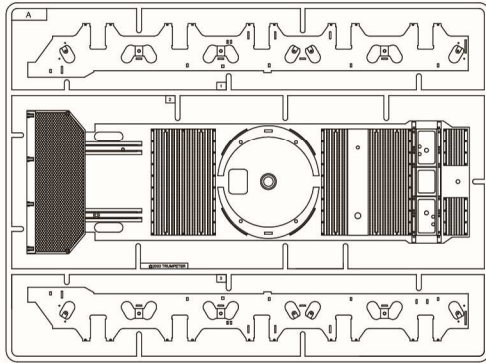

B x 4

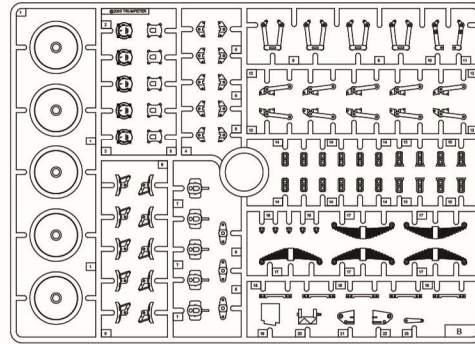

C x 2

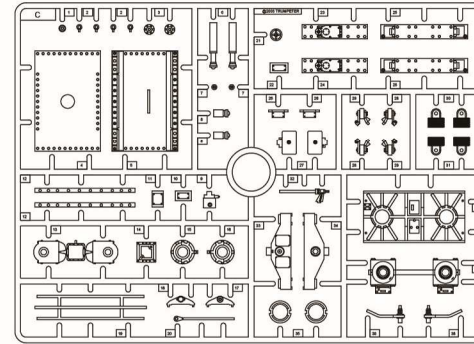

G

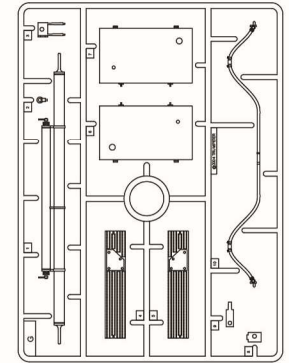

D x 2

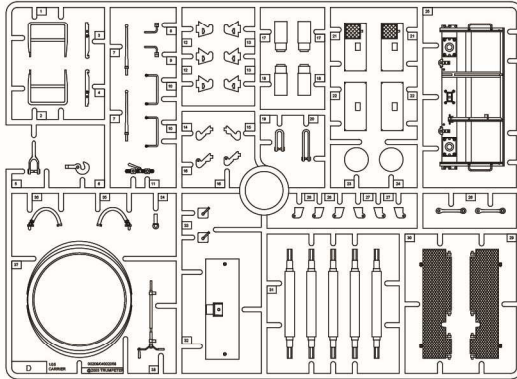

L x 2

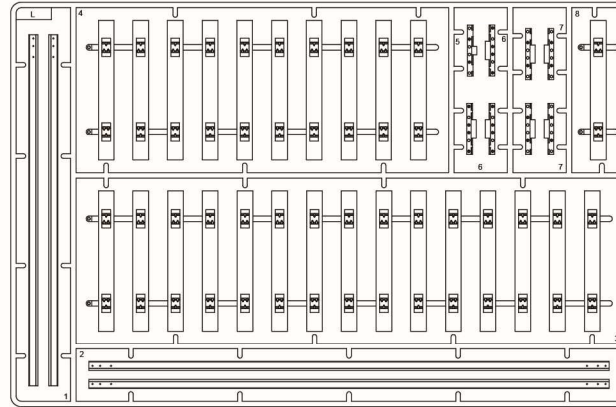

E x 2

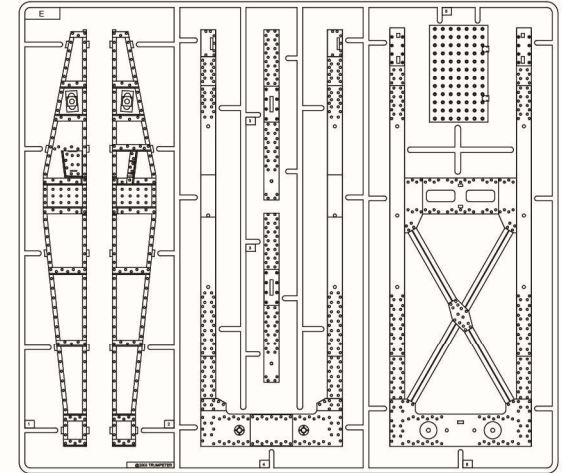

F x 2

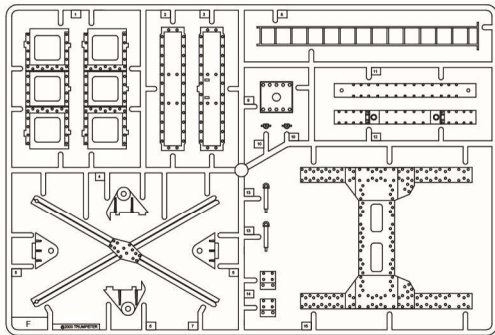

路基 A x 2
Road bed A x 2



路基 B x 4
Road bed B x 4

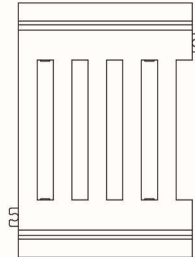

路基 C x 2
Road bed C x 2

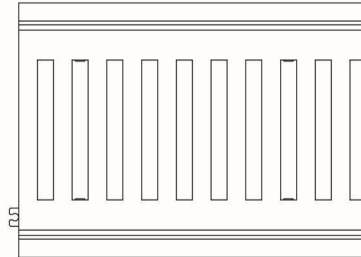

《聚乙烯套》 x 2
Poly cap x 2



《蚀刻片》 A
Photo etched part (PE) A

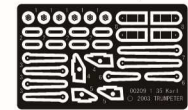

部品图 Parts

H x 2

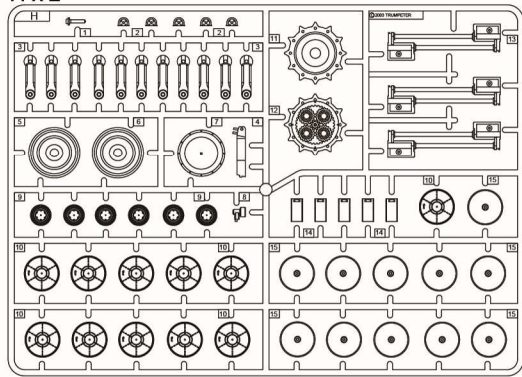

J x 2

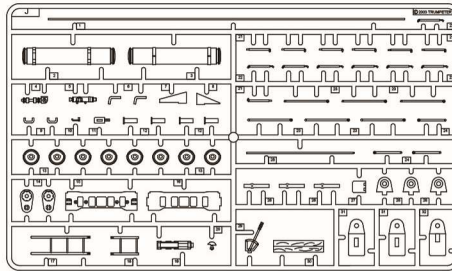

K

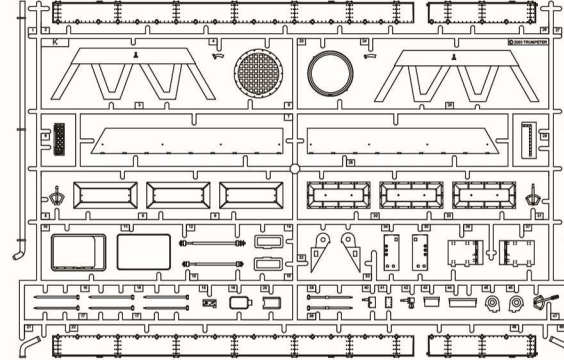

车底
Hull



M

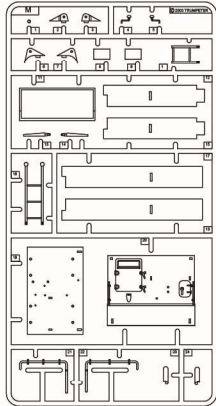

N

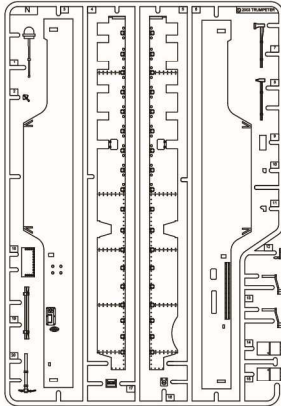

车面
Upper hull

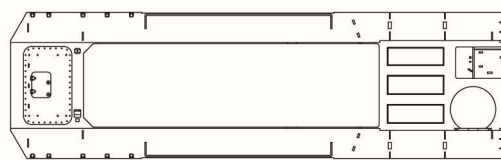

R

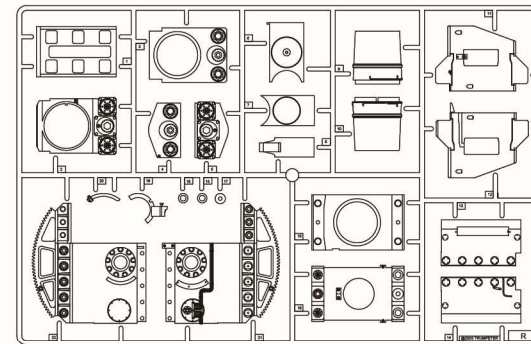

《蚀刻片》B
Photo etched part (PE) B

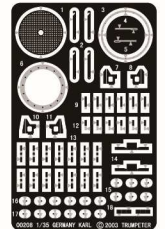

P

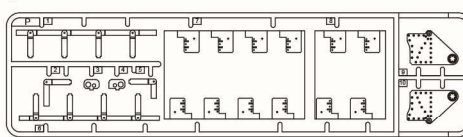

Q

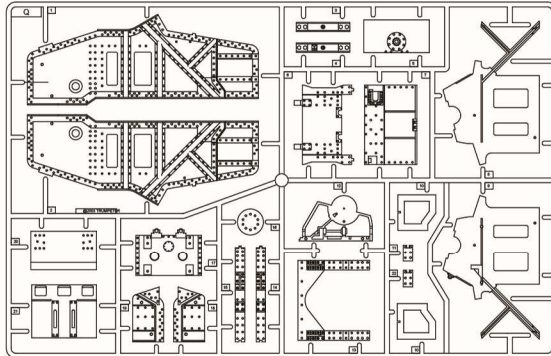

T

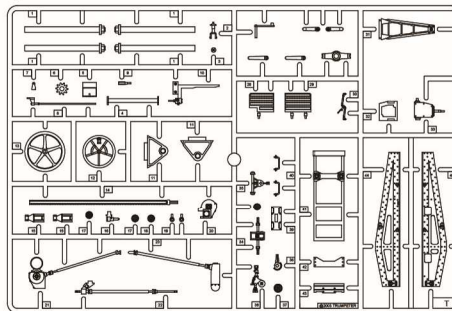

S

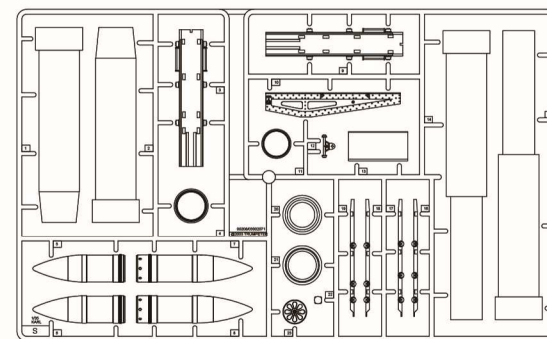

弹簧 $\varnothing 4.0 \times 35\text{mm} \times 4$
Spring $\varnothing 4.0 \times 35\text{mm} \times 4$

长金属轴 $\varnothing 2.0 \times 35\text{mm} \times 2$
Long shaft $\varnothing 2.0 \times 35\text{mm} \times 2$

短金属轴 $\varnothing 2.5 \times 16\text{mm}$
Short shaft $\varnothing 2.5 \times 16\text{mm}$

履带 x 2
Track x 2

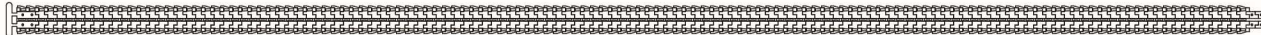

1 枕木安装
Attaching crossie

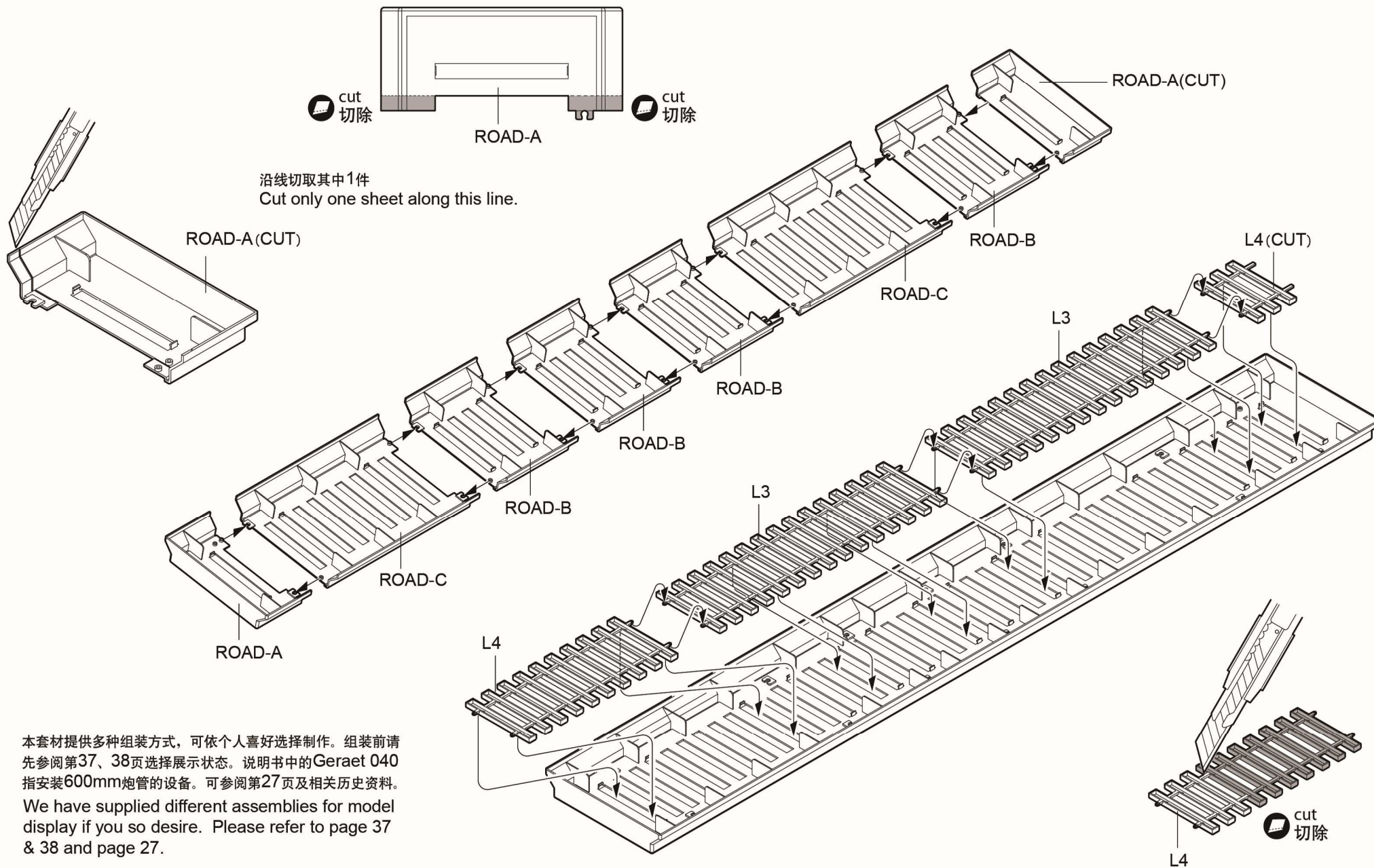

本套材提供多种组装方式，可依个人喜好选择制作。组装前请先参阅第37、38页选择展示状态。说明书中的Geraet 040指安装600mm炮管的设备。可参阅第27页及相关历史资料。
We have supplied different assemblies for model display if you so desire. Please refer to page 37 & 38 and page 27.

2 铁轨安装
Attaching rail

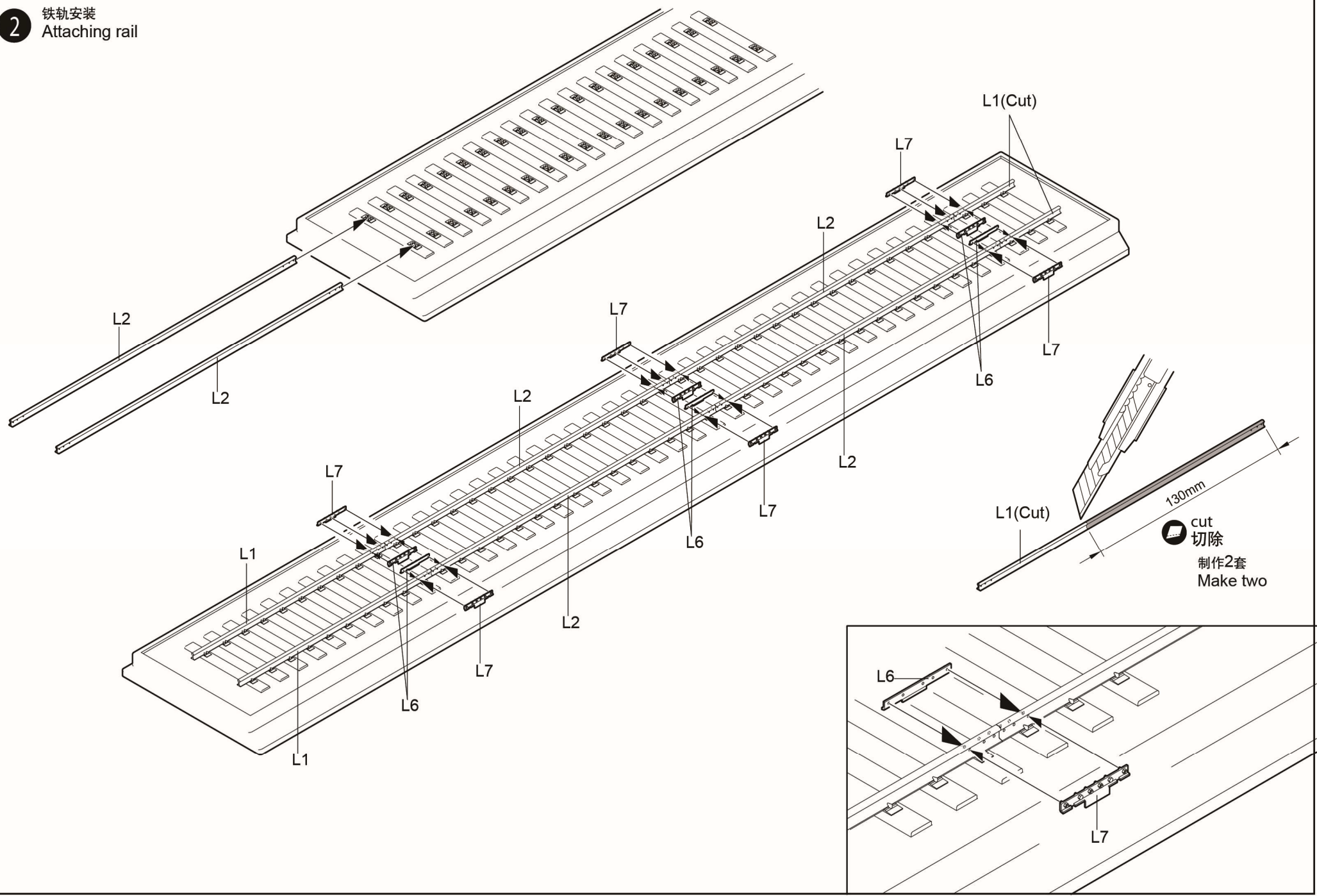

3 左侧悬挂组装
Left suspension assembly

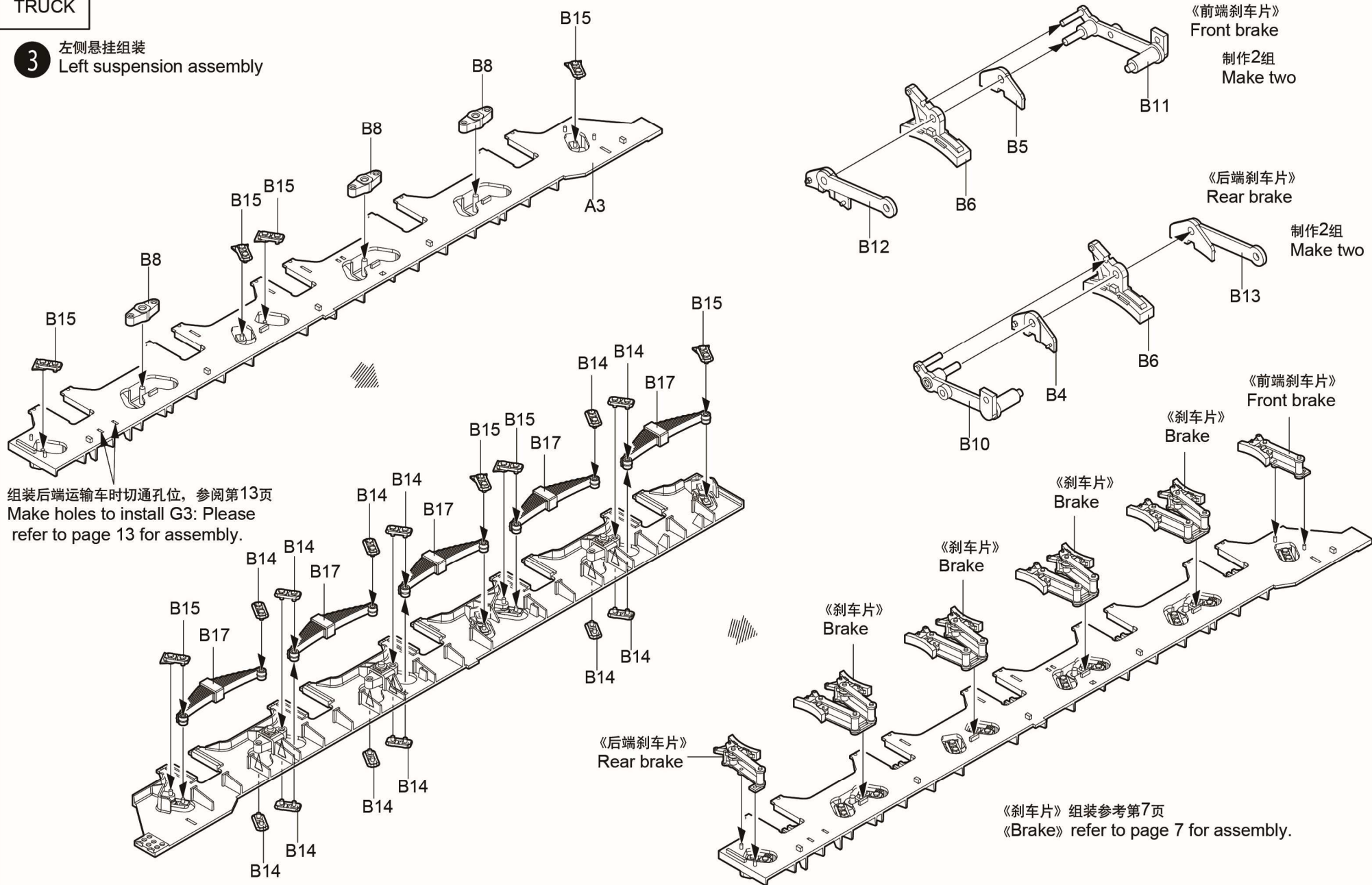

组装后端运输车时切通孔位, 参阅第13页
Make holes to install G3: Please refer to page 13 for assembly.

《刹车片》 组装参考第7页
《Brake》 refer to page 7 for assembly.

4 右侧悬挂组装
Right suspension assembly

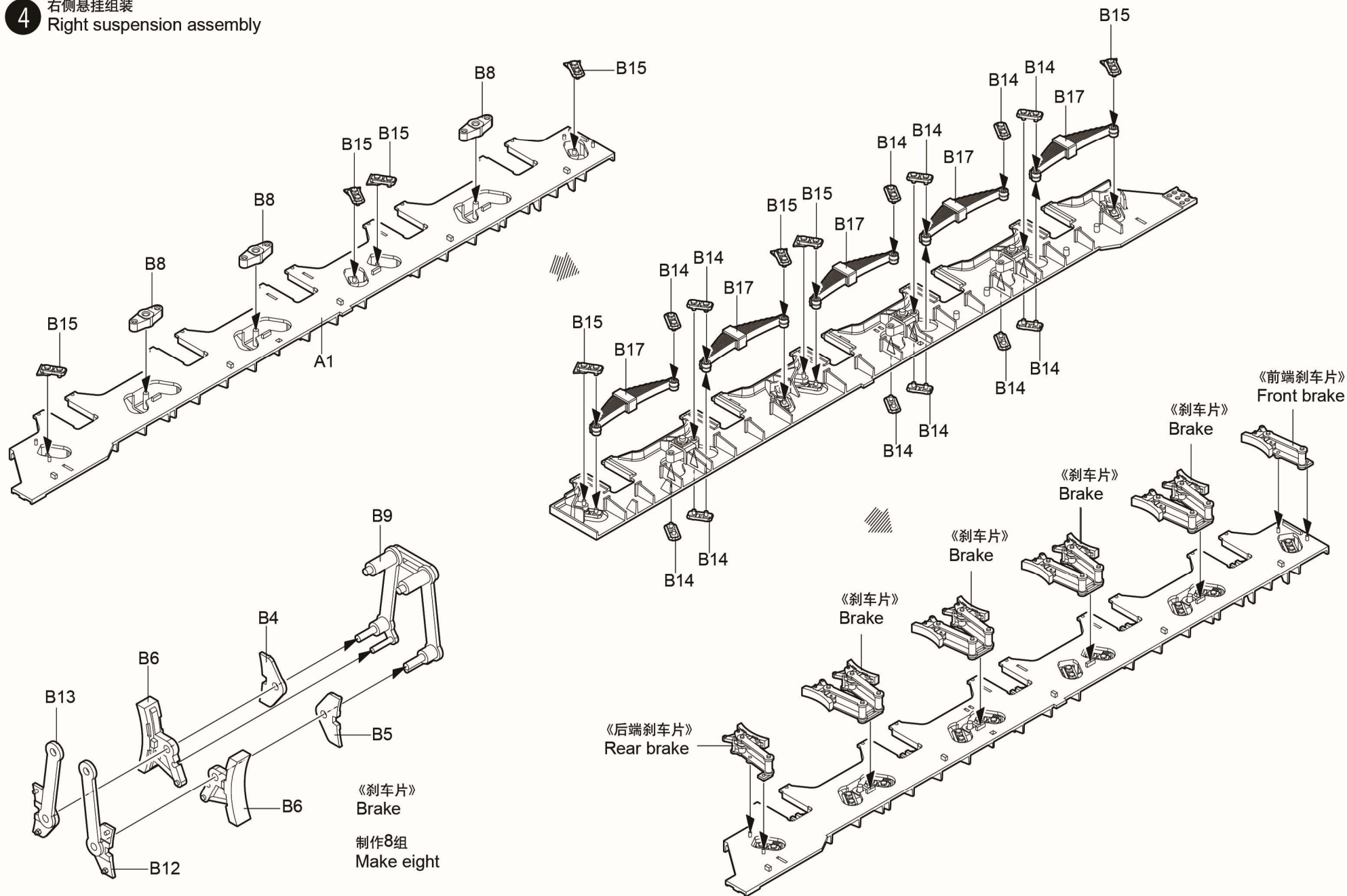

5 车轮组装
Wheel assembly

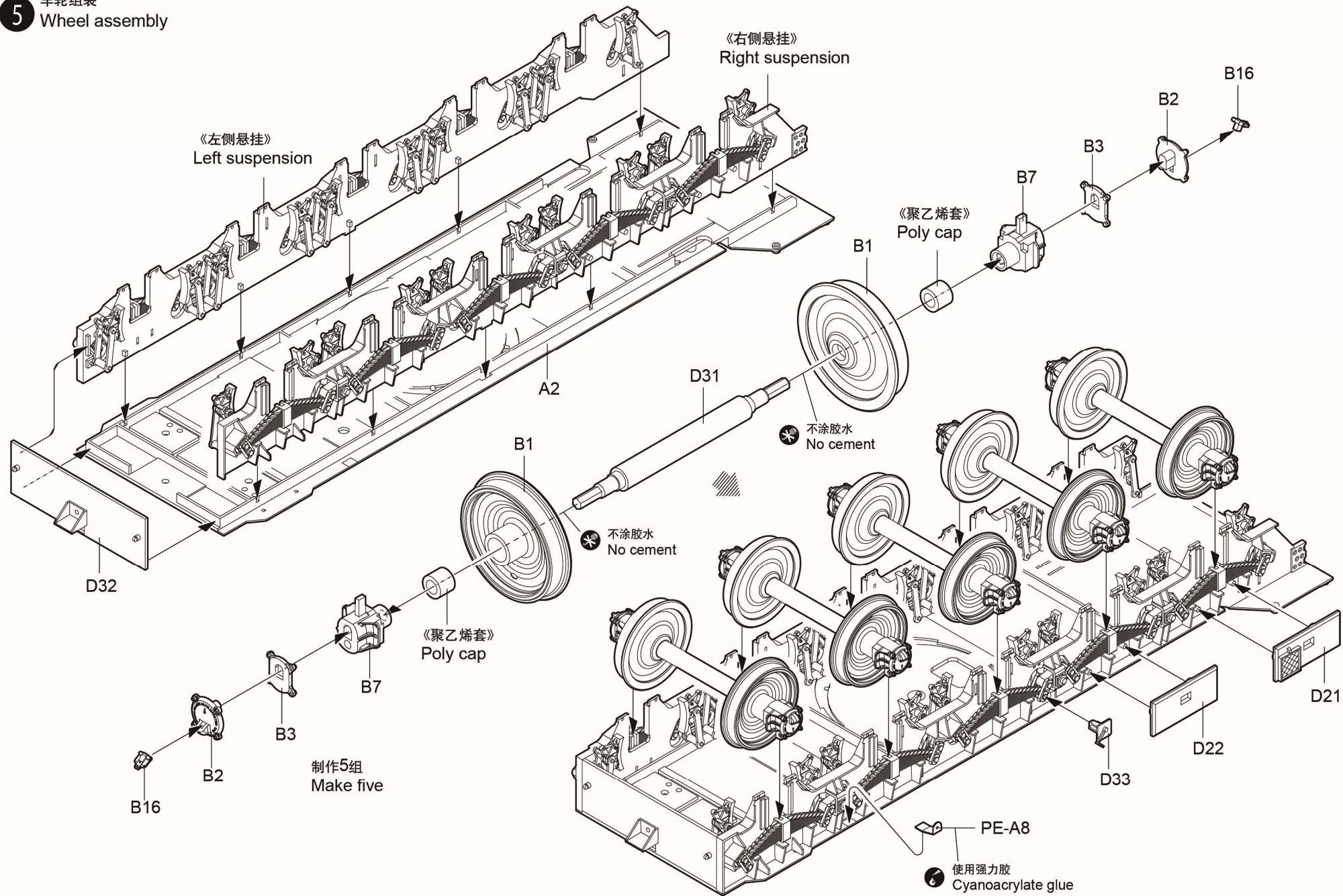

6 车尾组装
Rear truck assembly

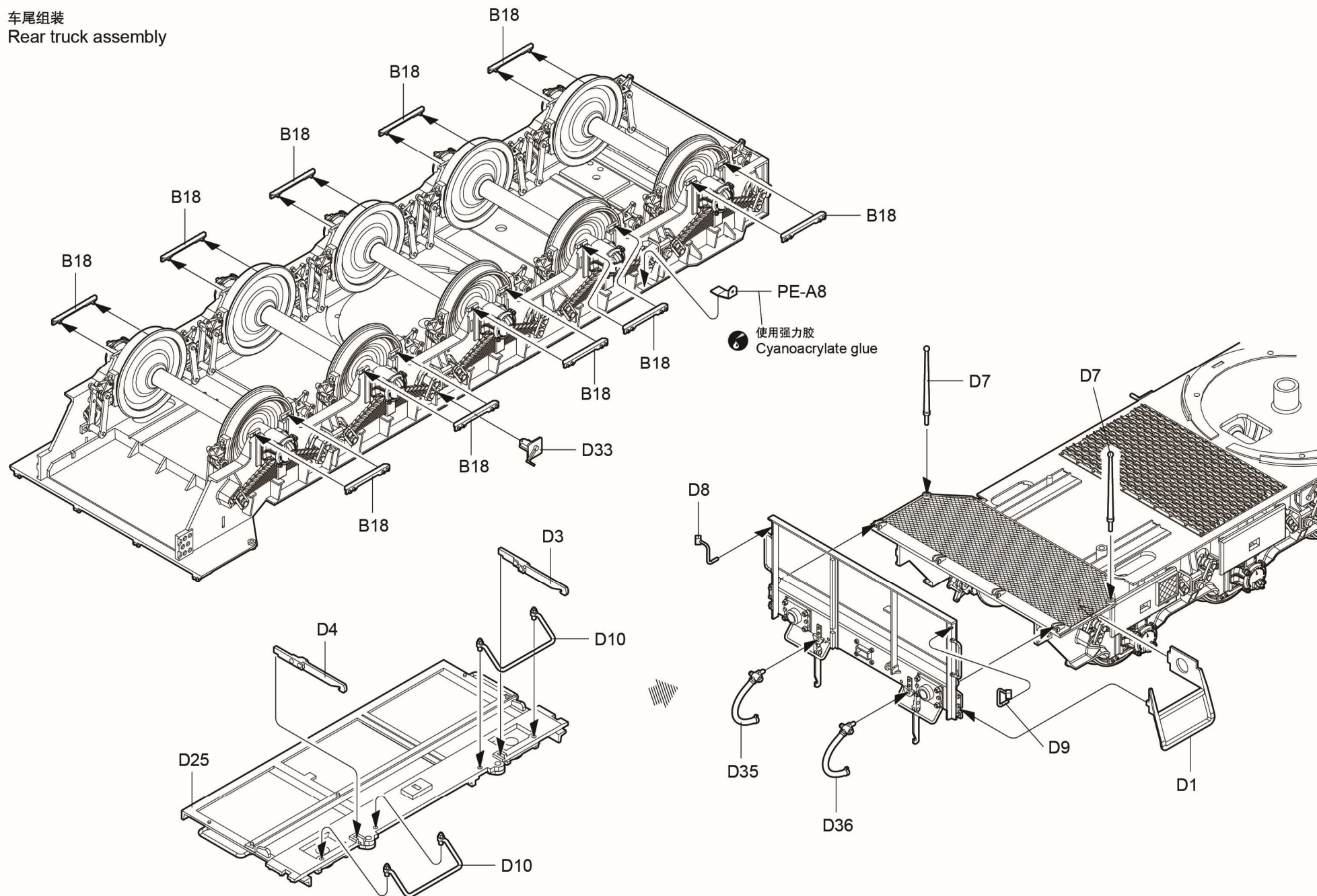

7 车尾组装
Rear truck assembly

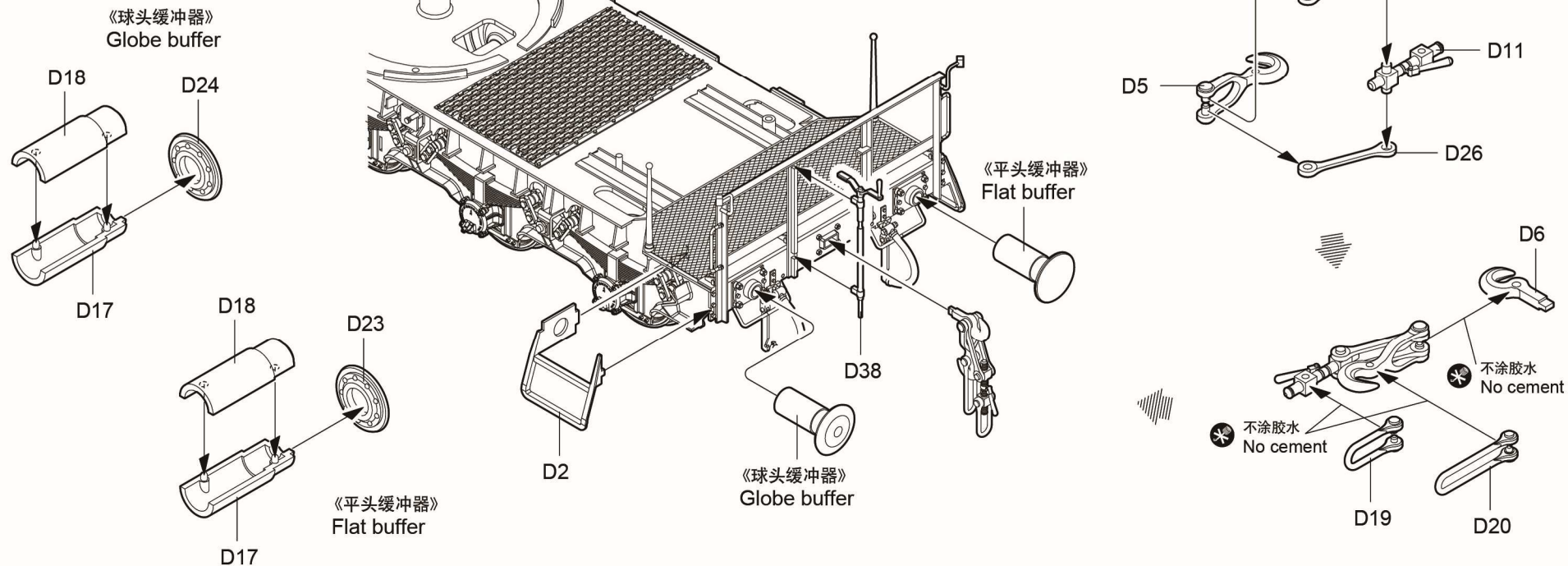

8 收放踏板组装
Footplate assembly

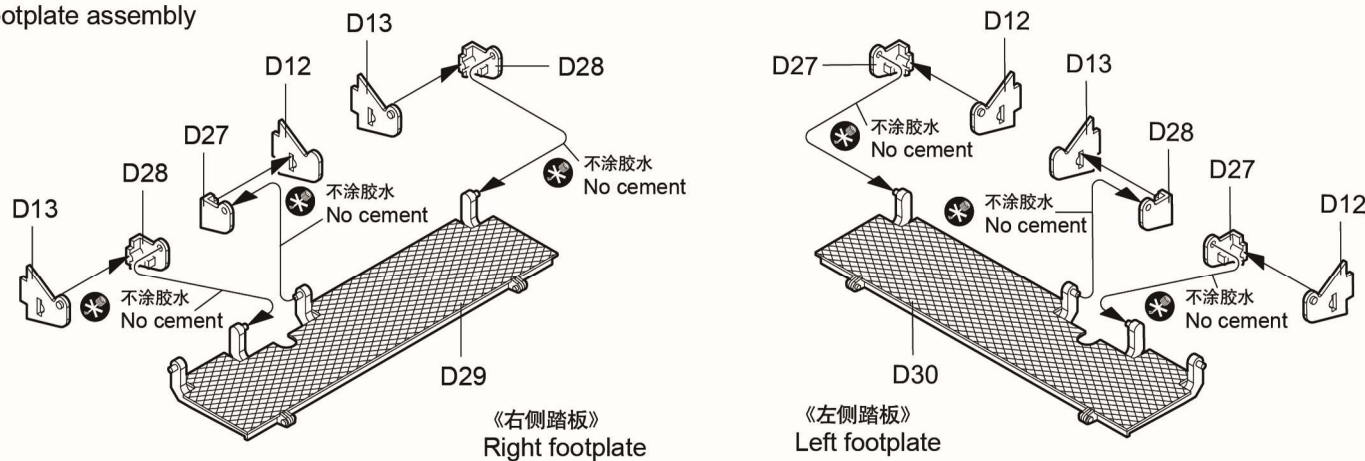

钻穿图中标示的孔位
Make holes

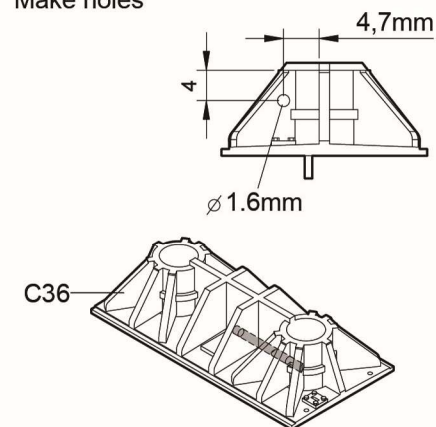

9 活动支撑座组装
Bearing assembly

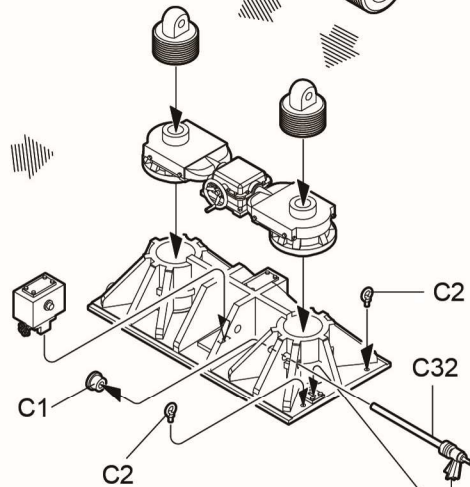
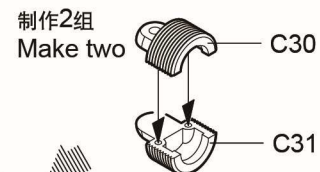
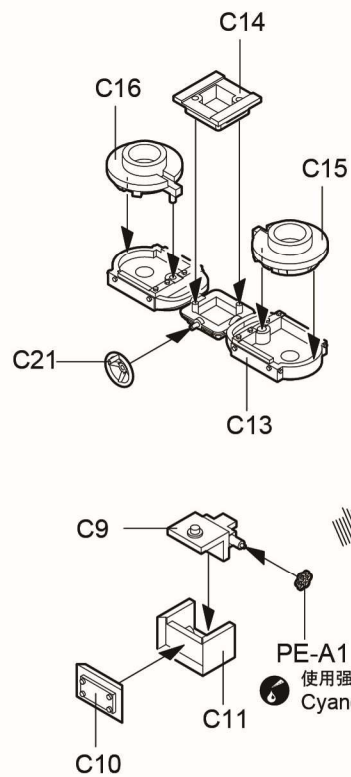
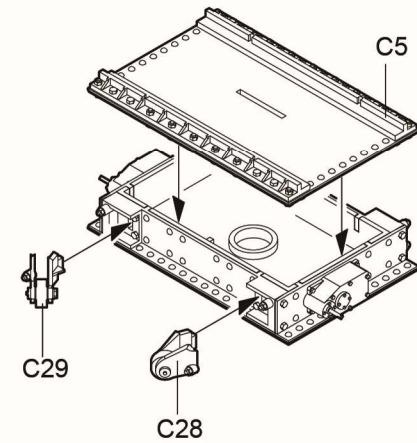
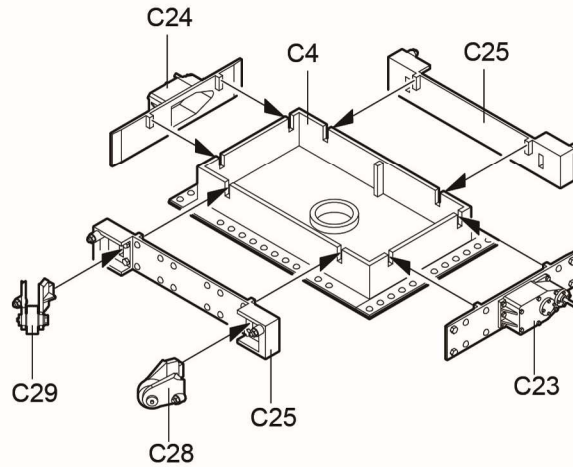
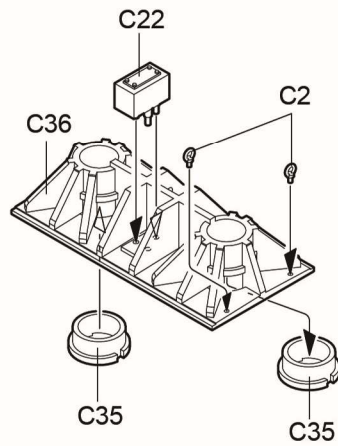

PE-A1
使用强力胶
Cyanoacrylate glue

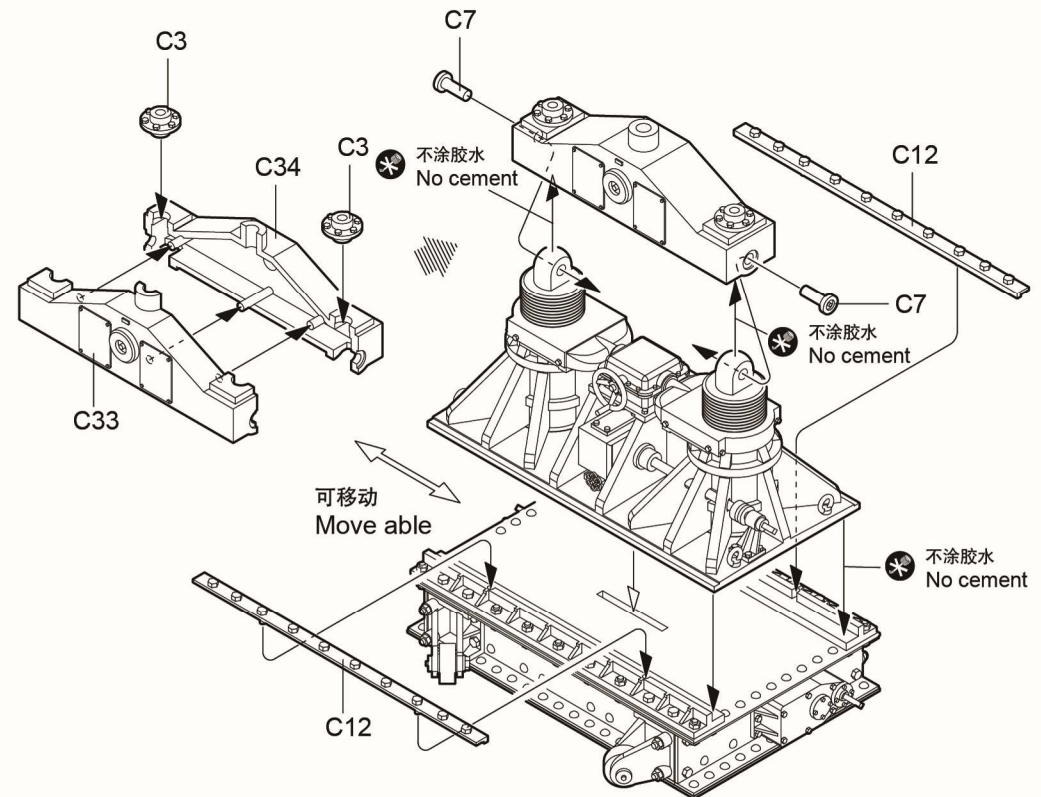

10 支撑座安装
Bearing intallation

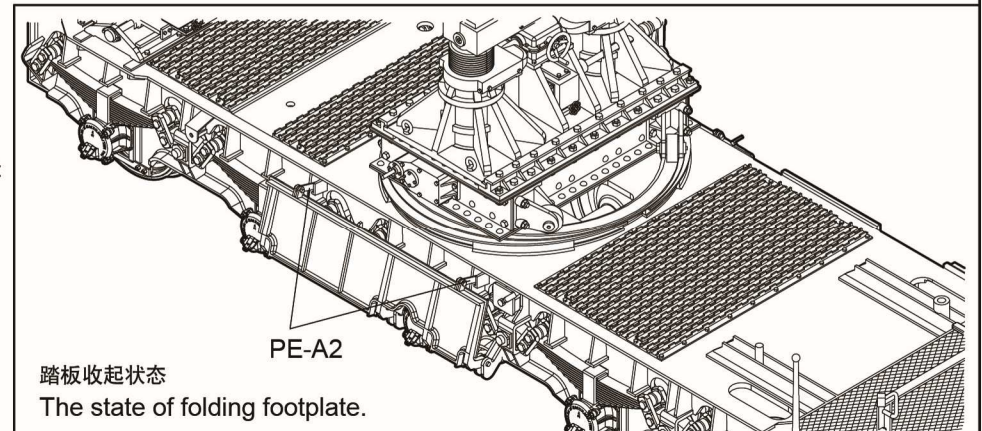
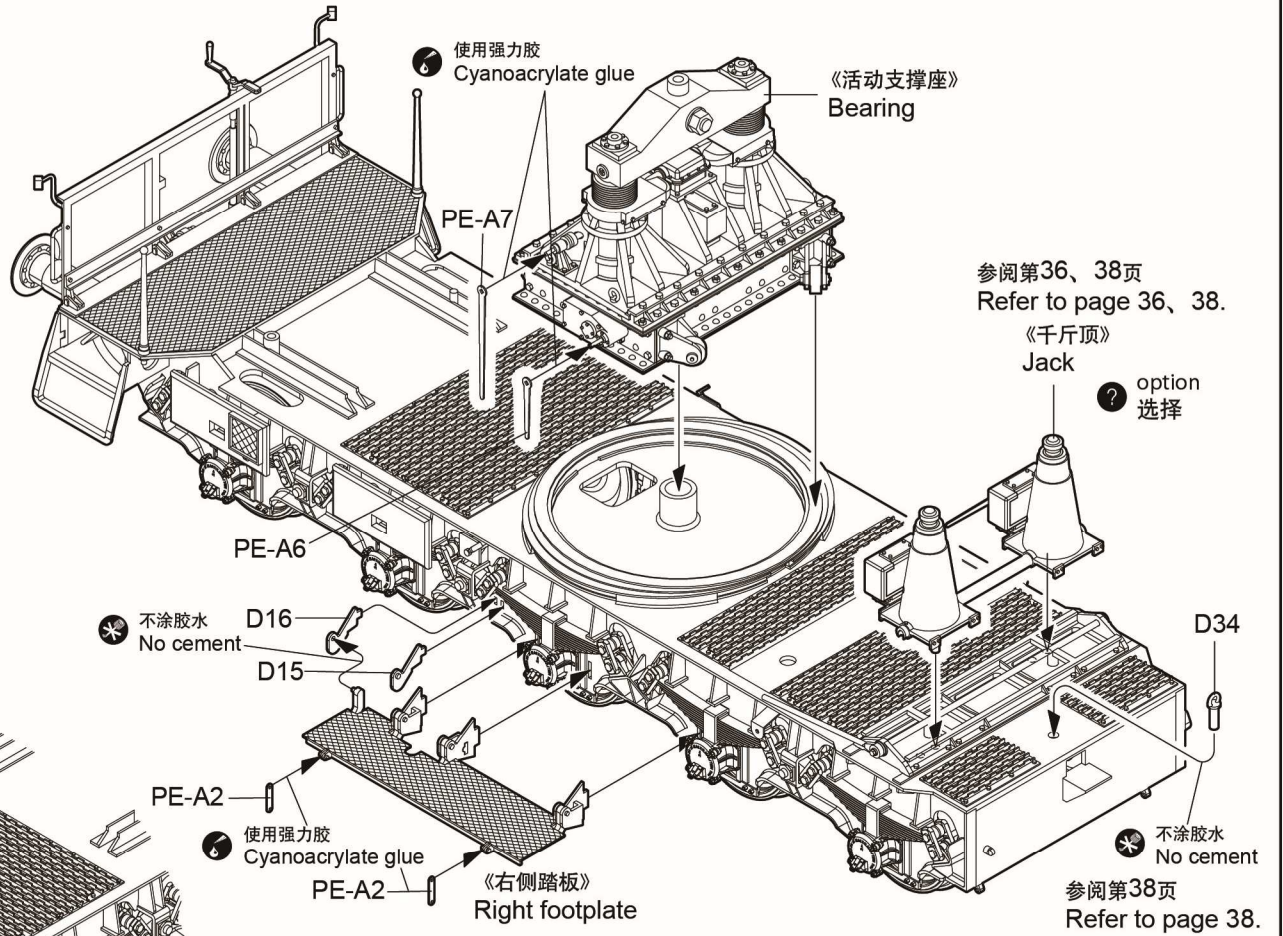
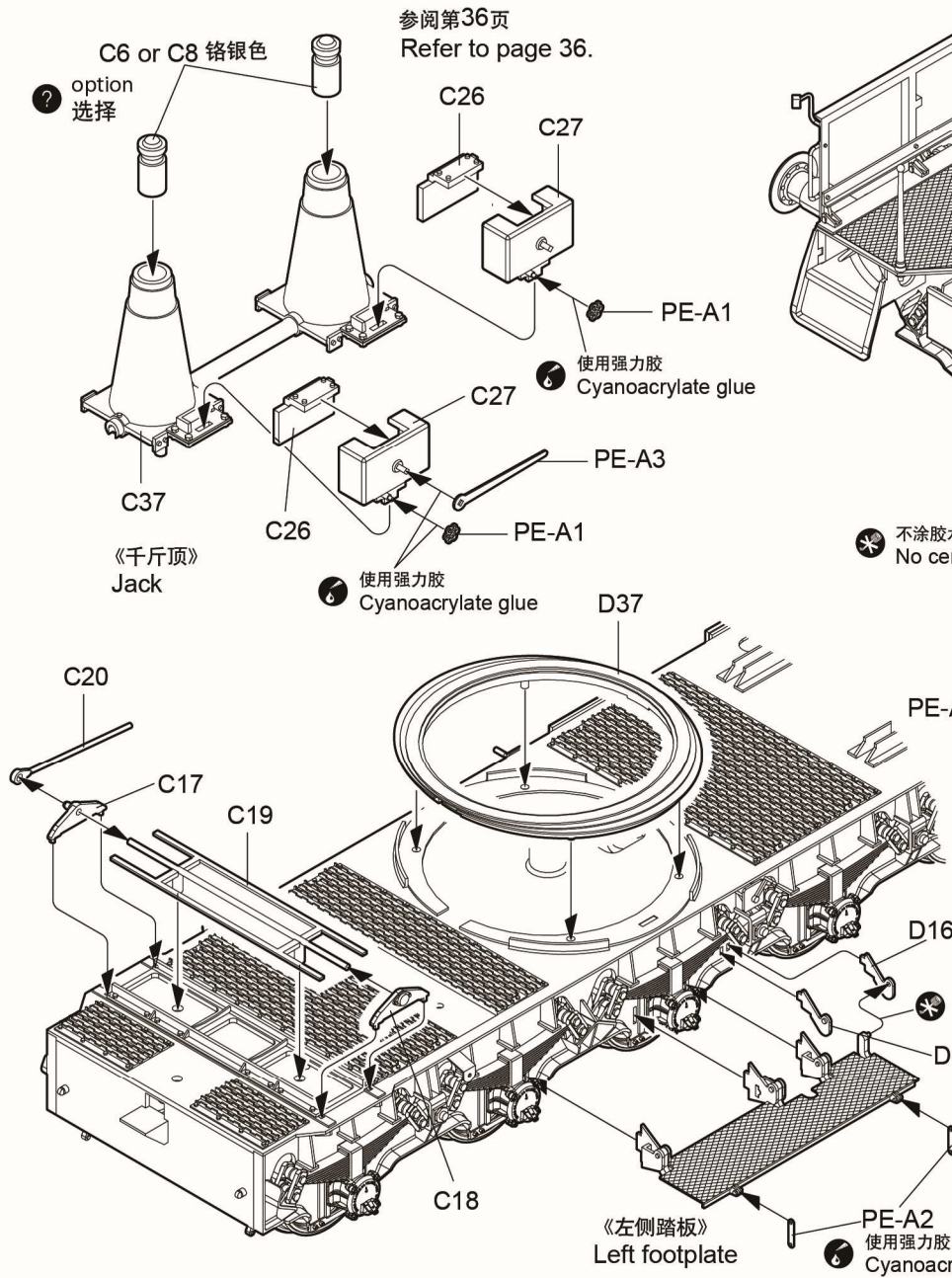

前、后运输车底部通用，重复步骤3-步骤10
 Front and rear truck are common, please repeat step to make two sets

11 前、后运输车组装
 Truck assembly

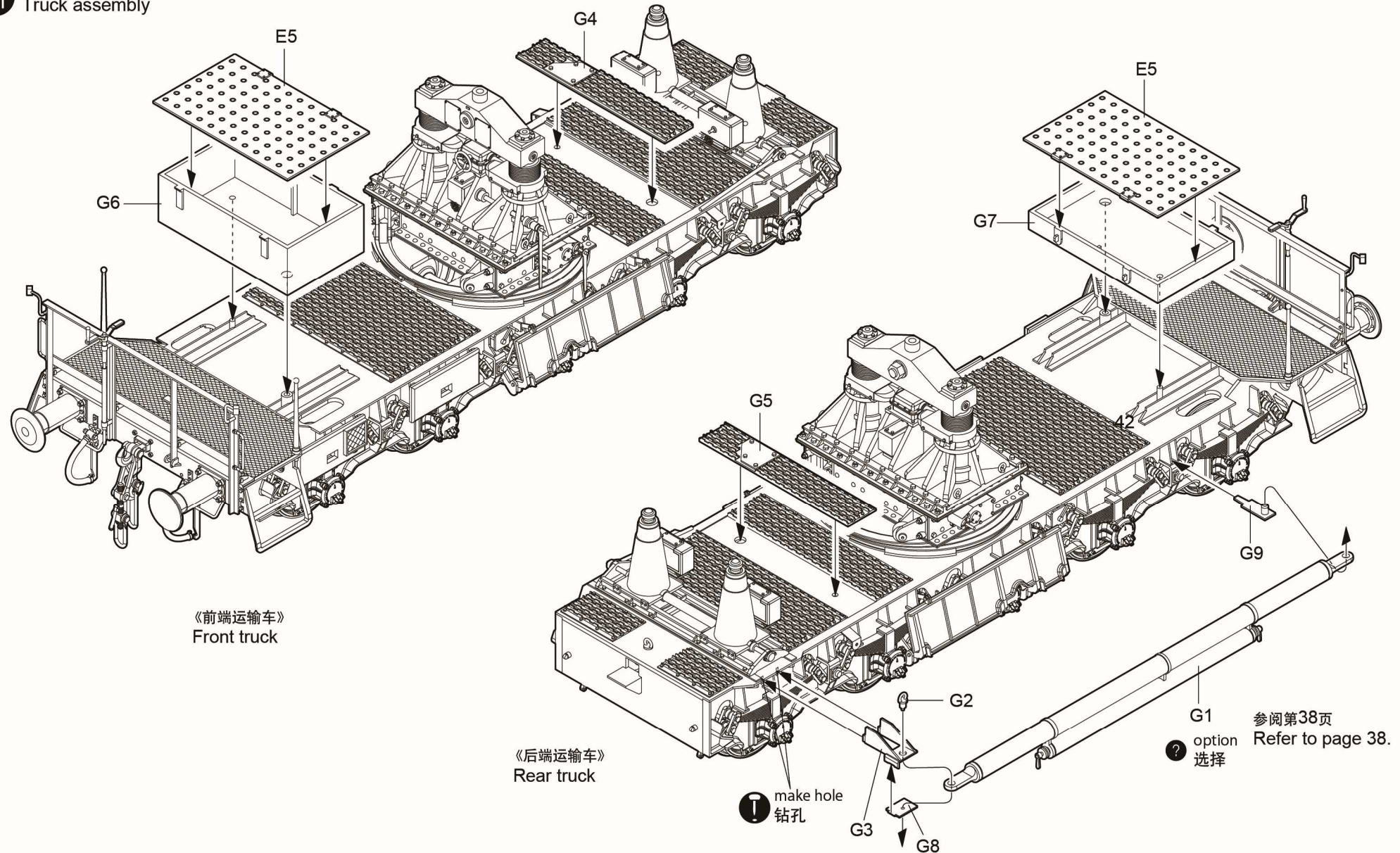

悬臂
ARM 制作2组
Make two

12 悬臂组装
Arm assembly

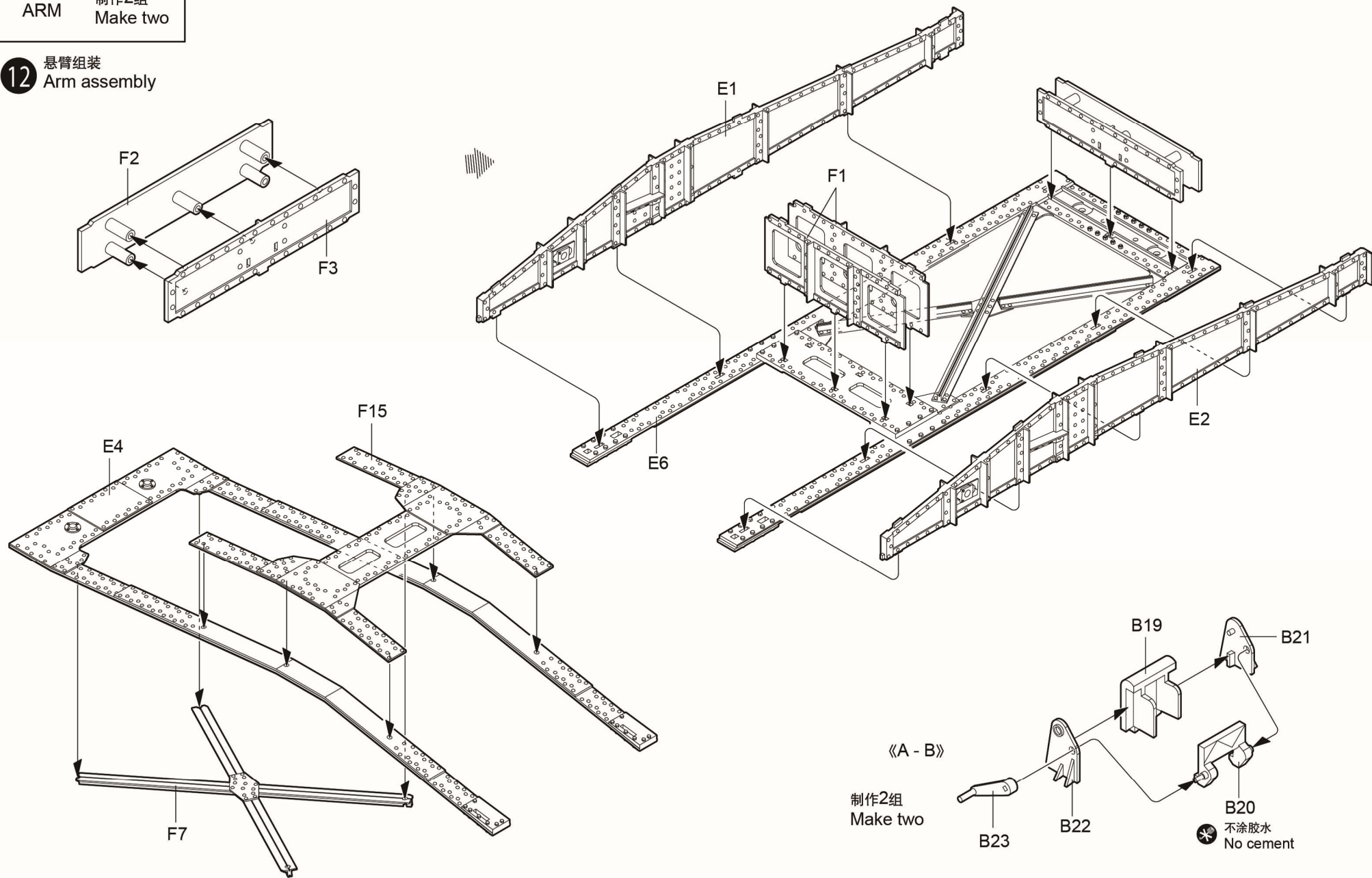

13 悬臂组装
Arm assembly

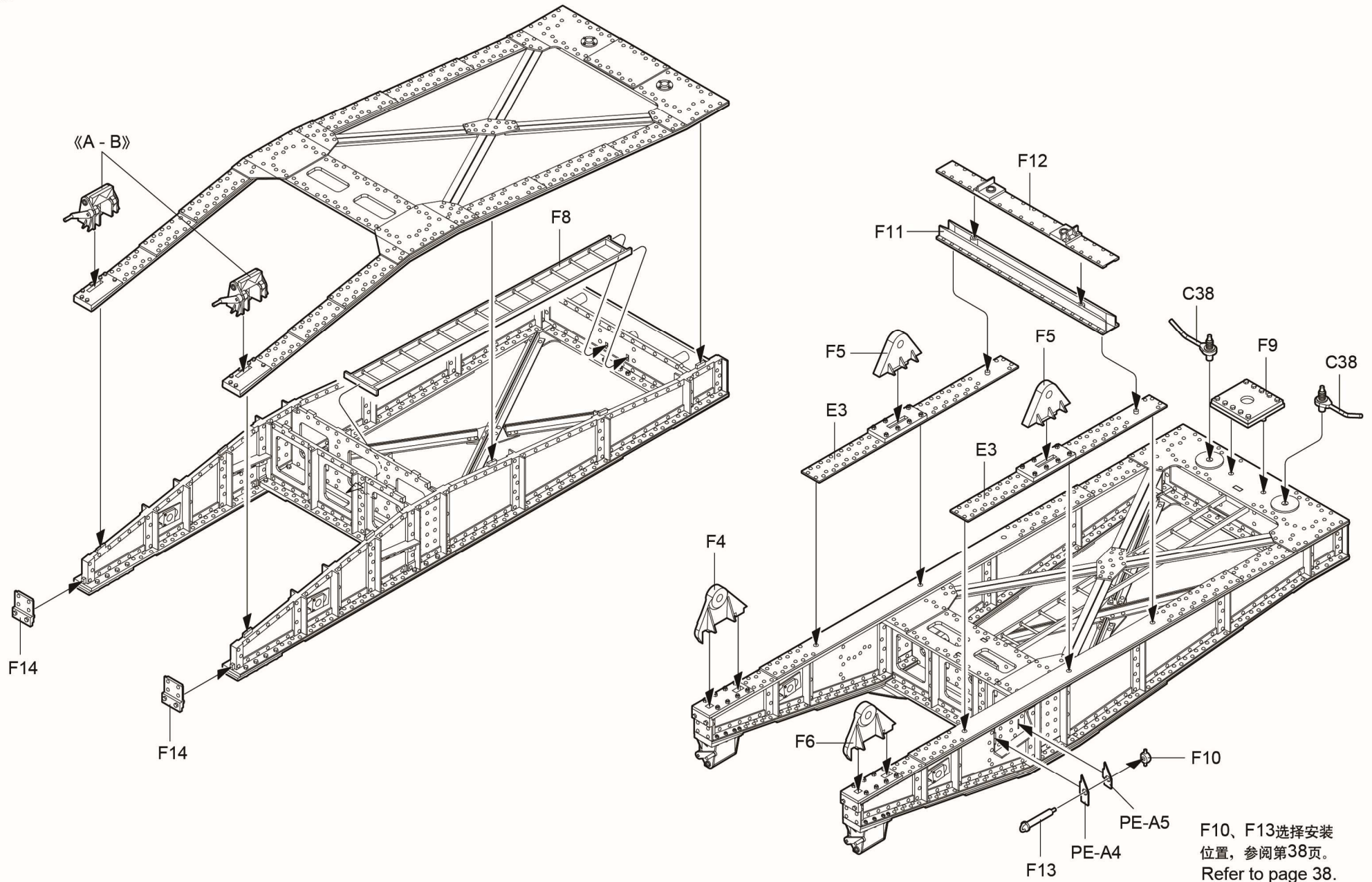

F10、F13选择安装位置，参阅第38页。
Refer to page 38.

1 车底组装
Lower hull assembly

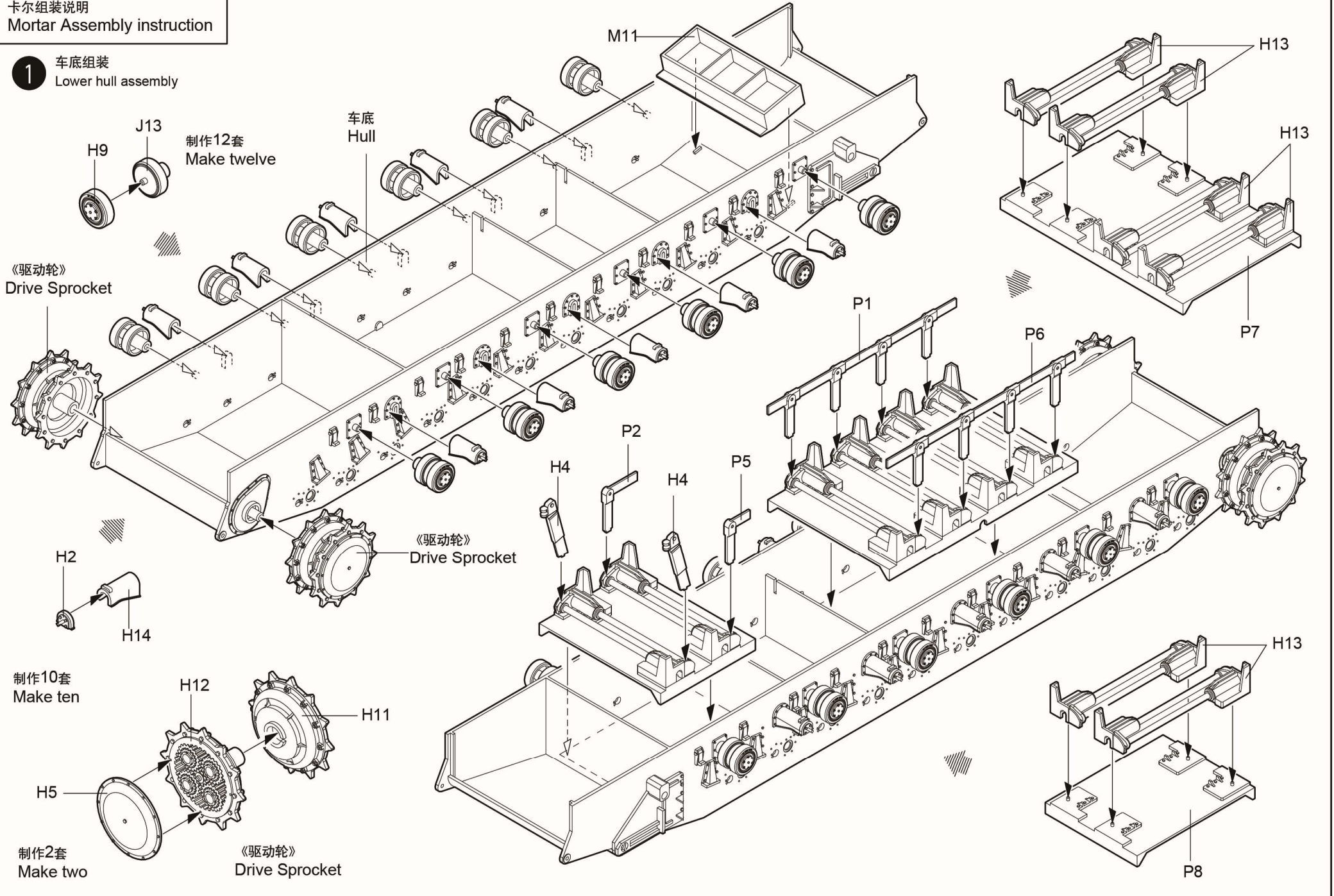

2 车底组装
Lower hull assembly

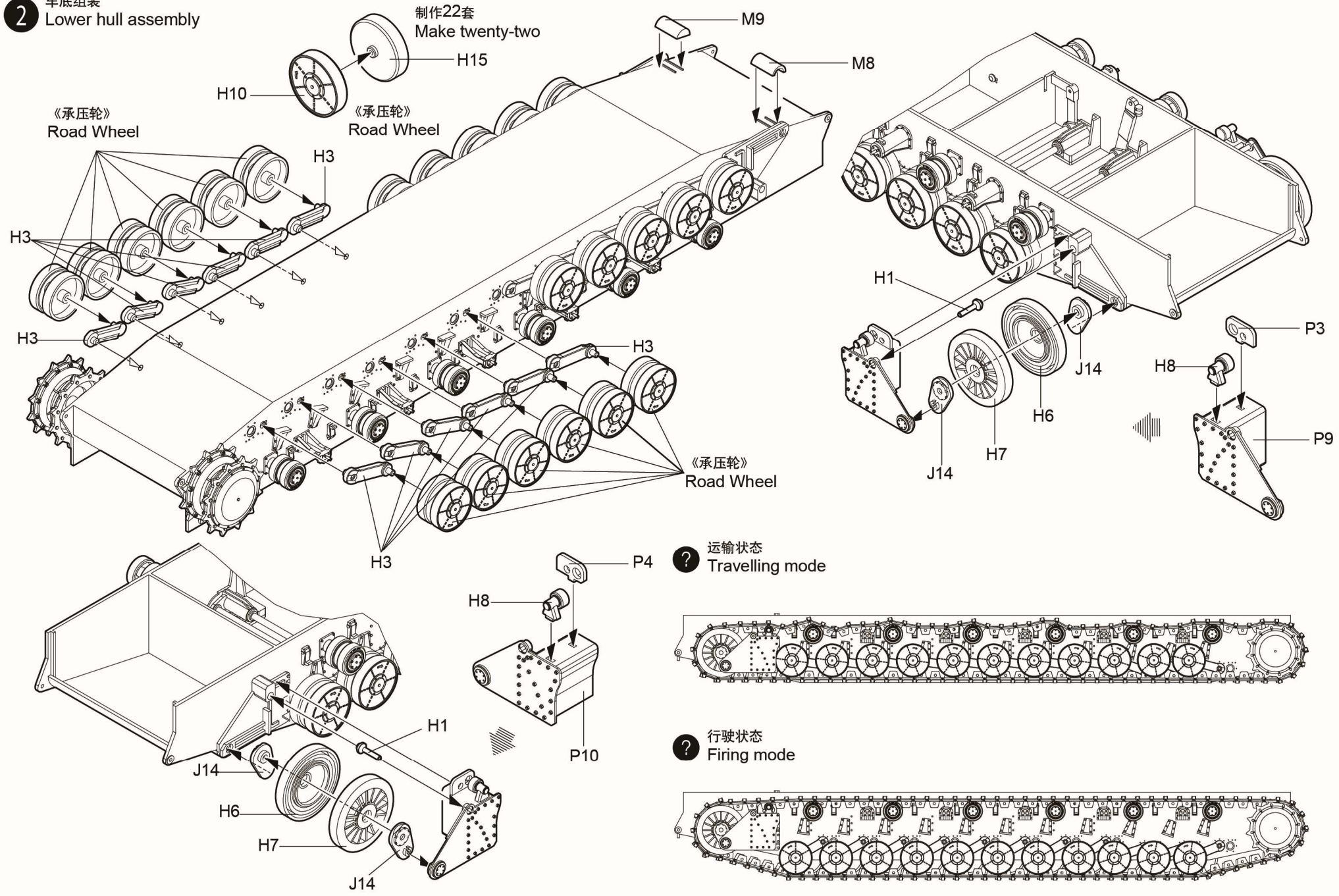

3 履带安装
Attaching track

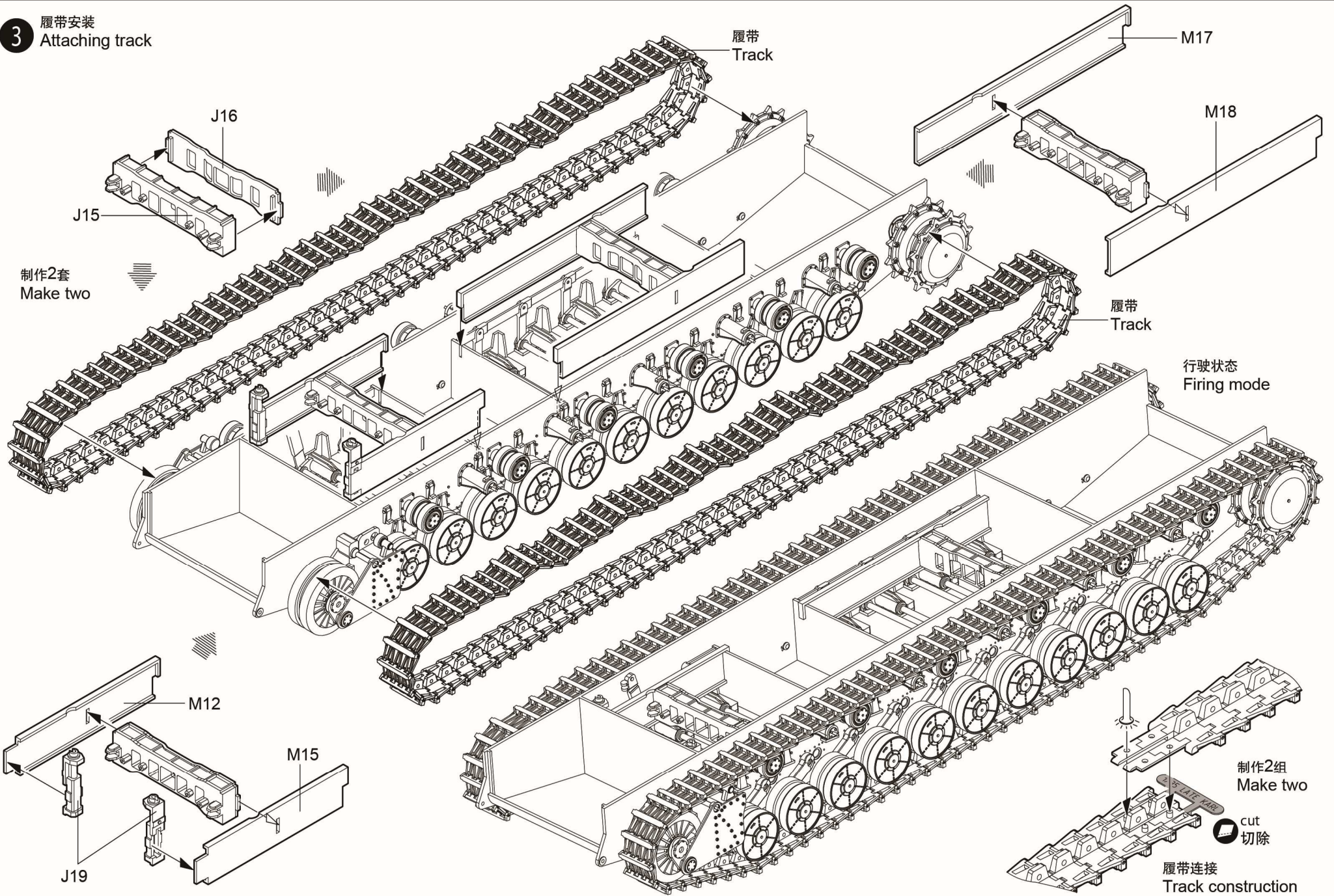

4 车体上部组装
Upper hull assembly

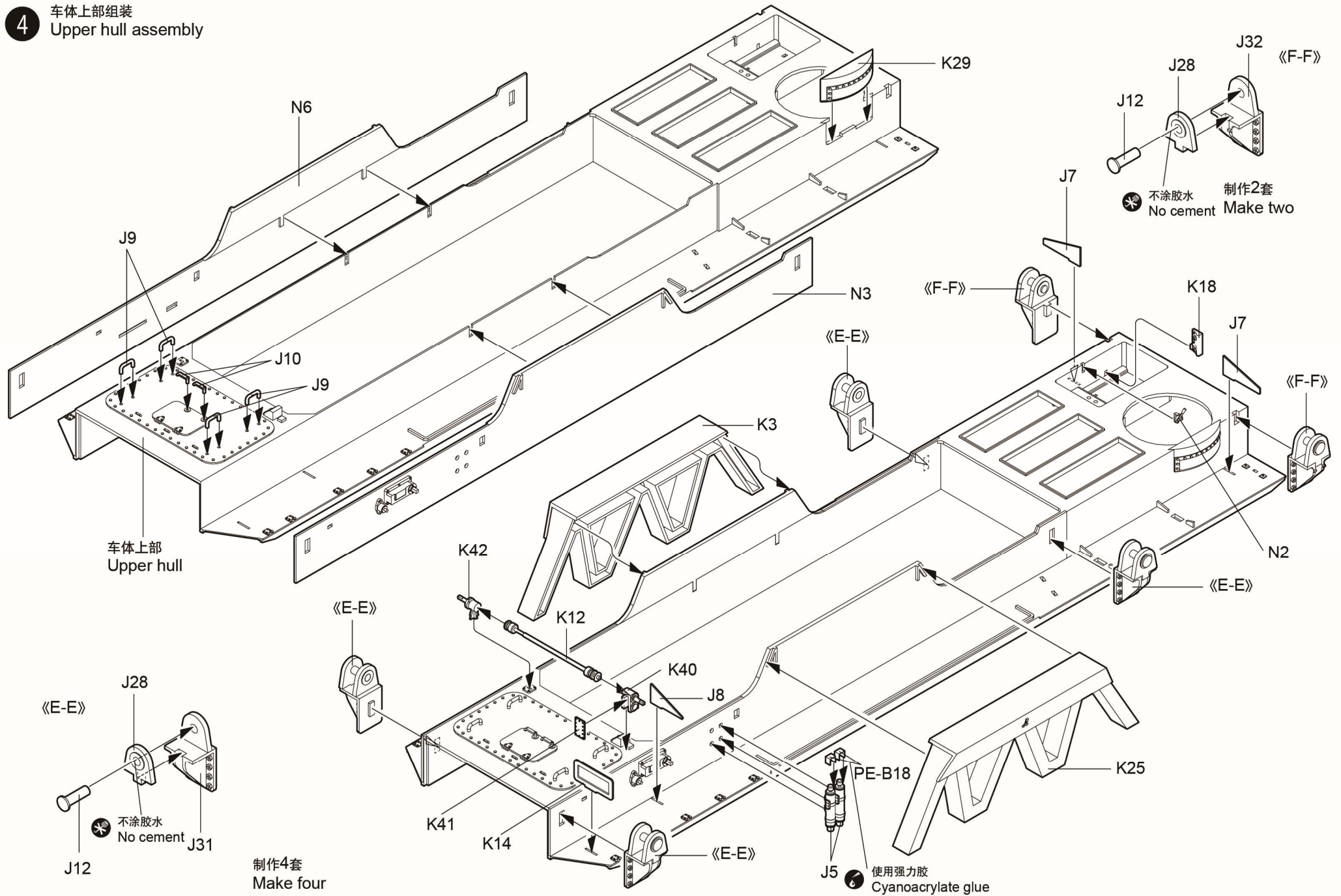

5 车体上部组装
Upper hull assembly

? K1、K27 运输状态不安装
K1、K27 not used for travelling mode

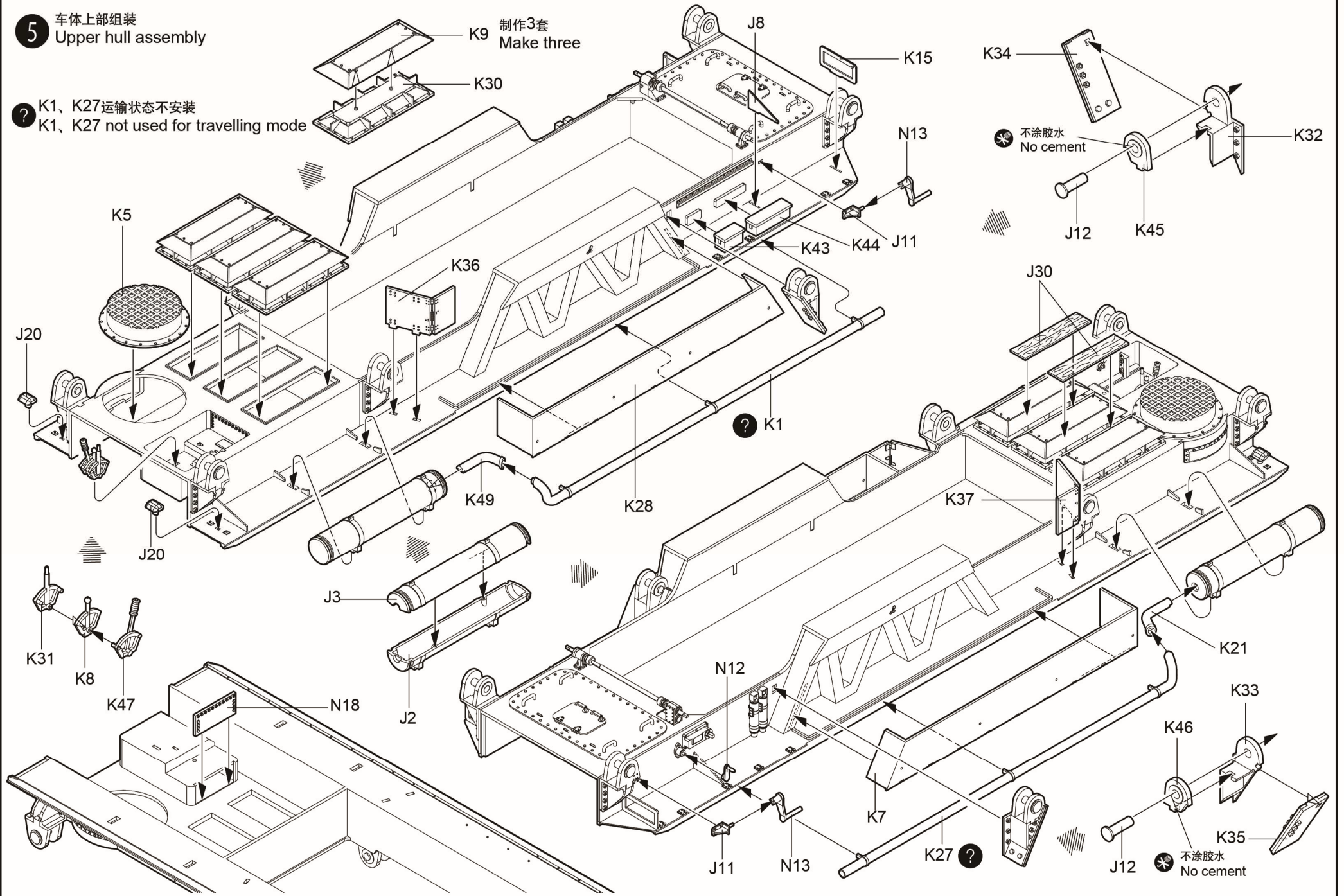

6 车体上部组装
Upper hull assembly

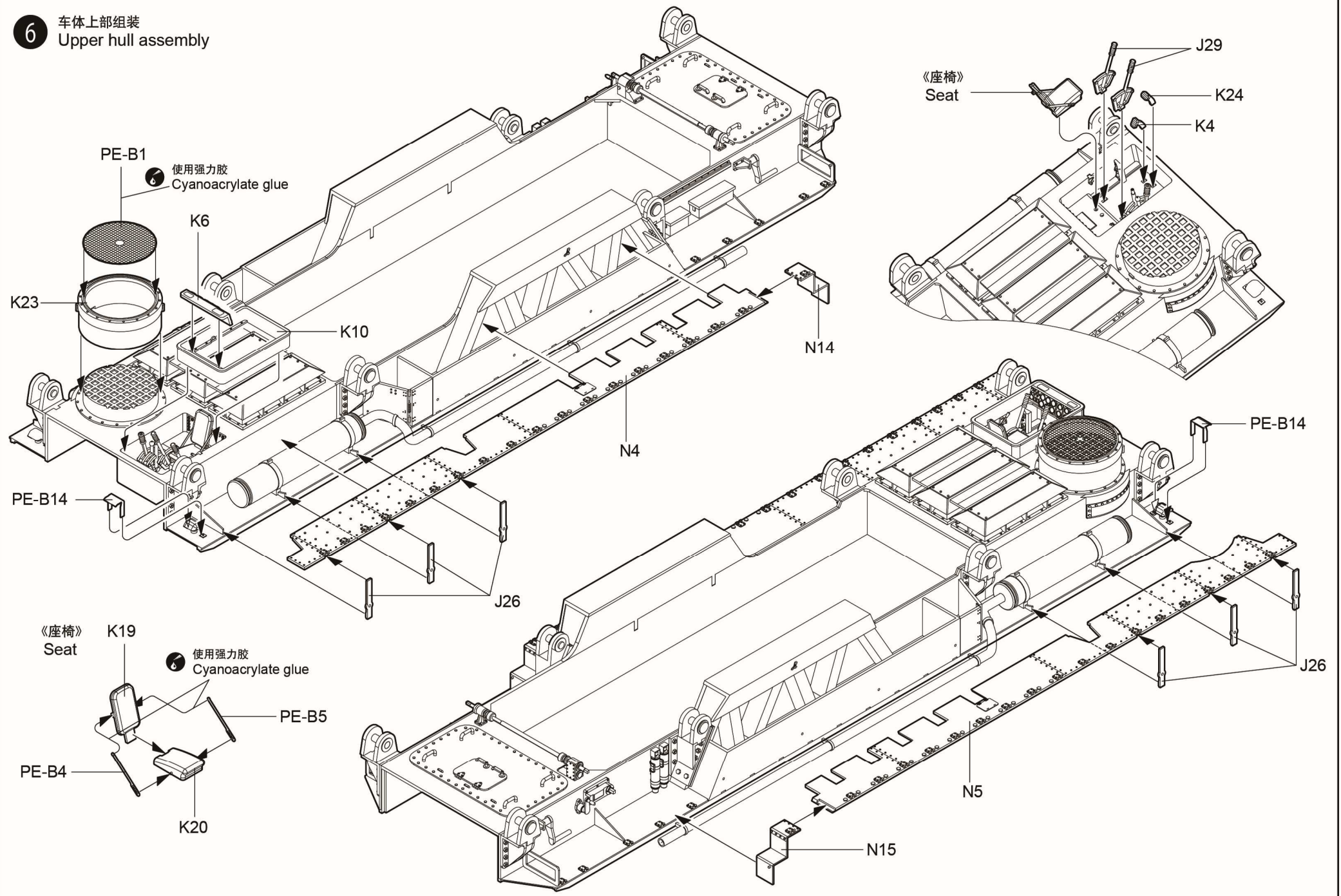

7 扶手组装
Hand rail assembly

? 运输状态组装
For travelling mode

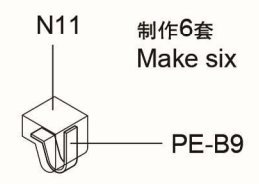
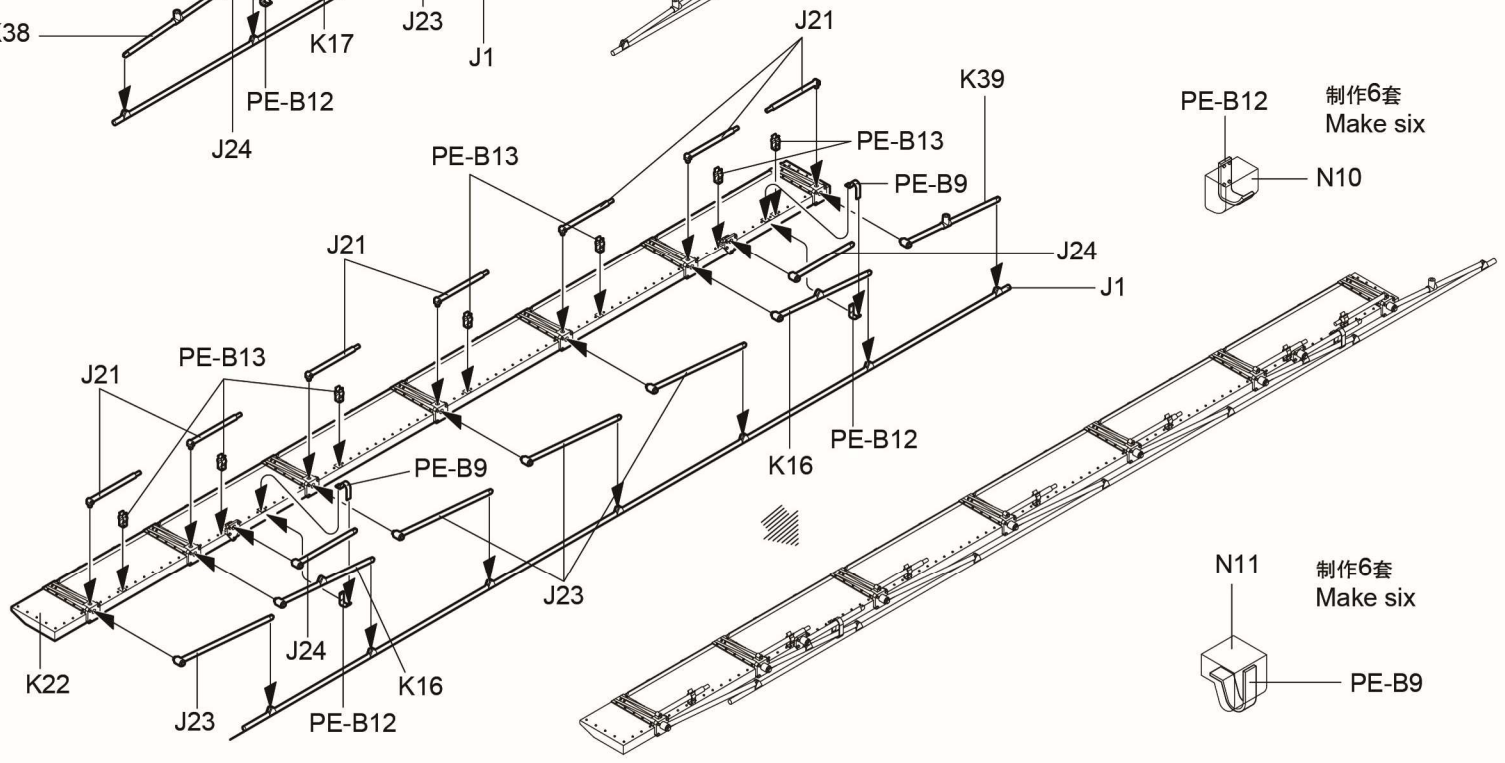
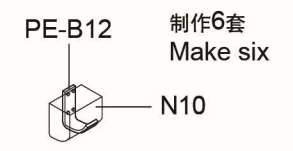
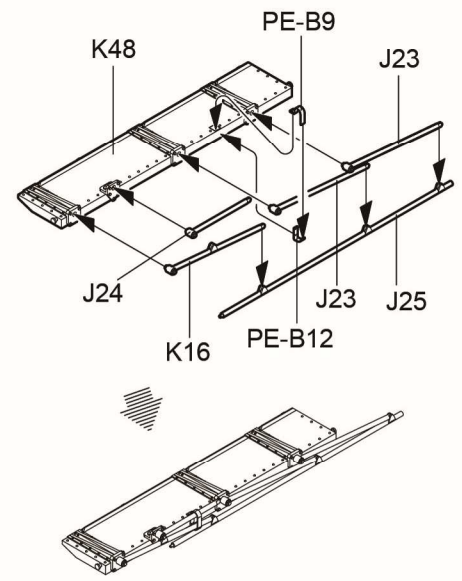
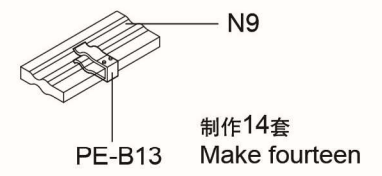
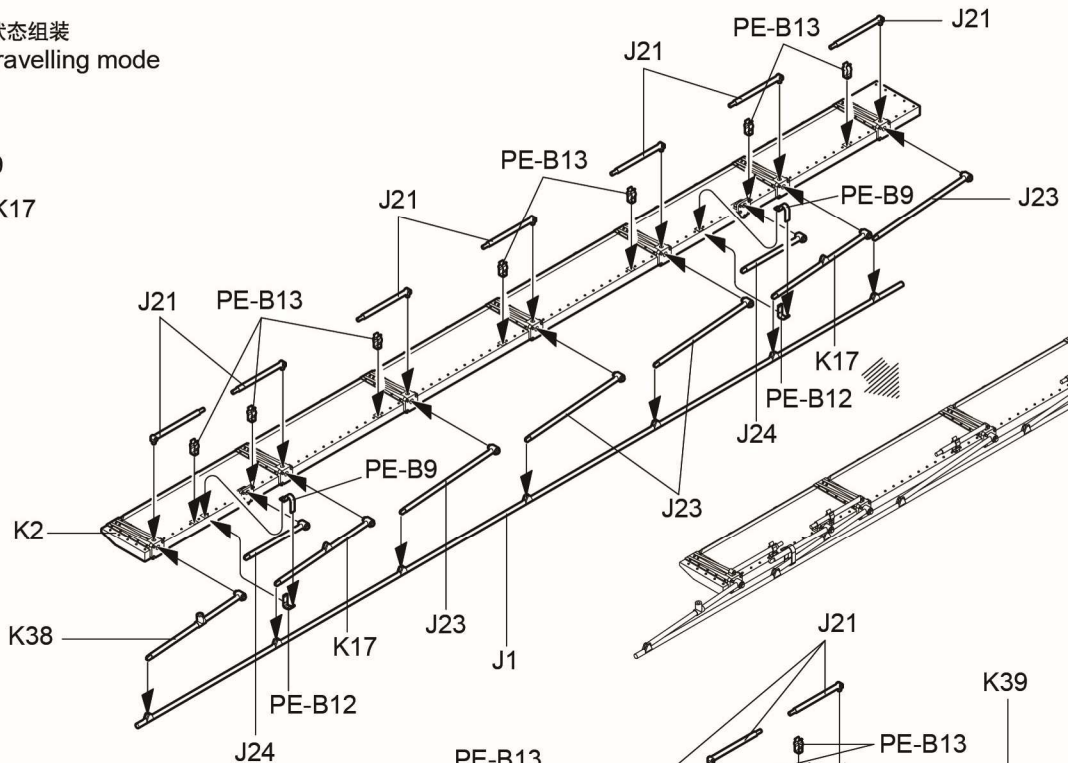
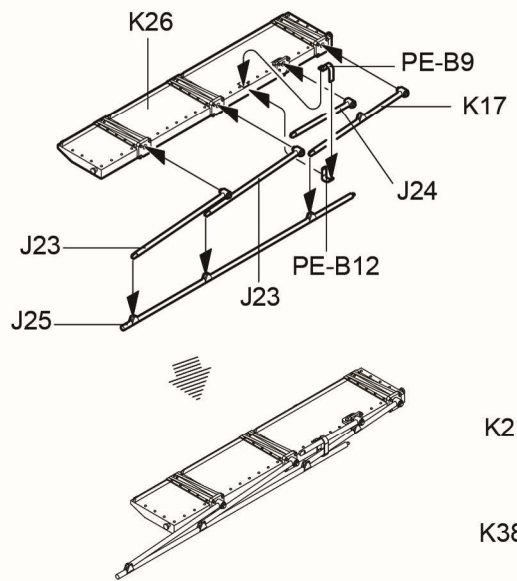

8 扶手安装
Attaching hand rail

? 运输状态组装
For travelling mode

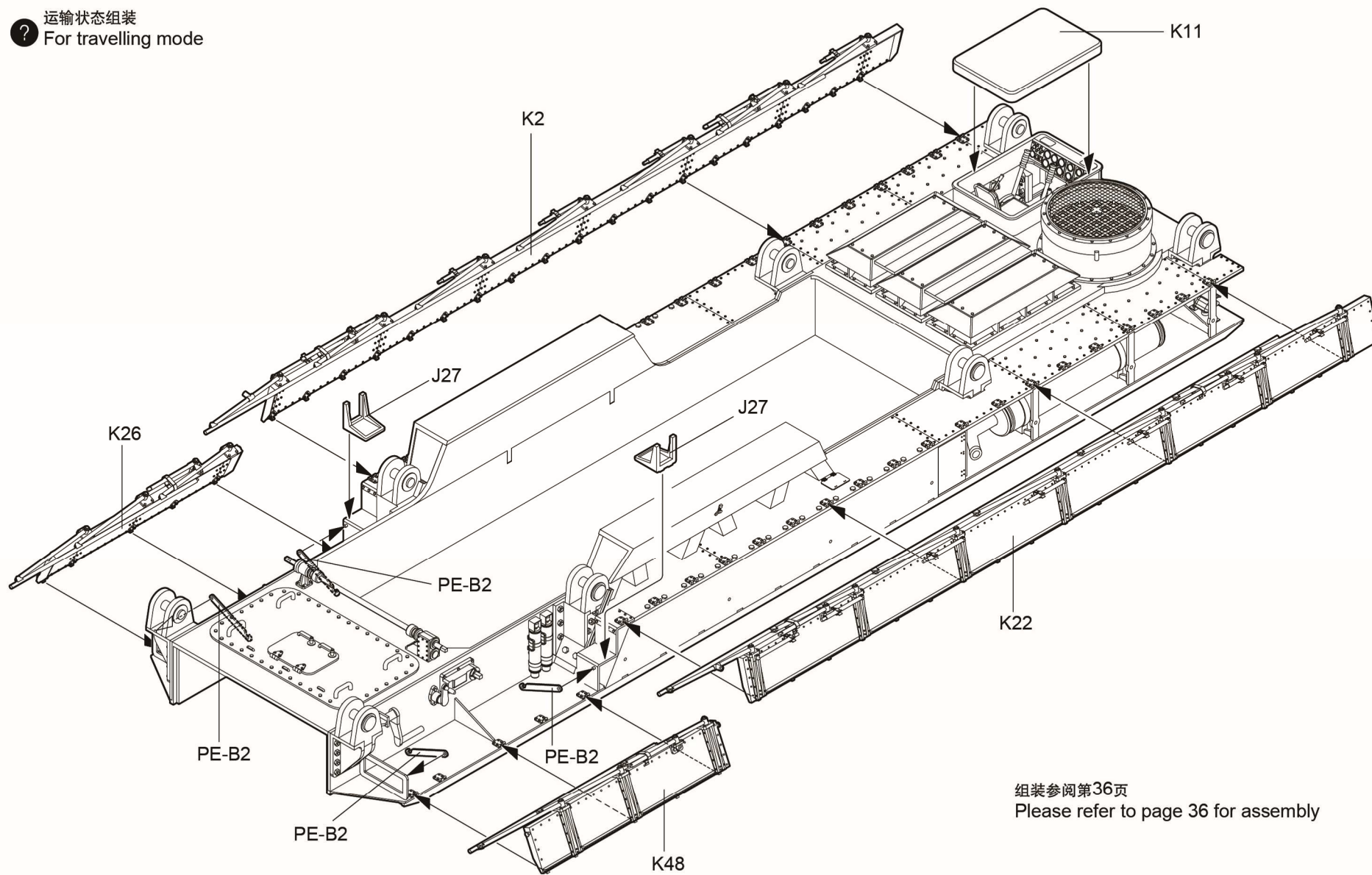

组装参阅第36页
Please refer to page 36 for assembly

7 扶手安装
Attaching hand rail

行驶状态组装
For firing mode

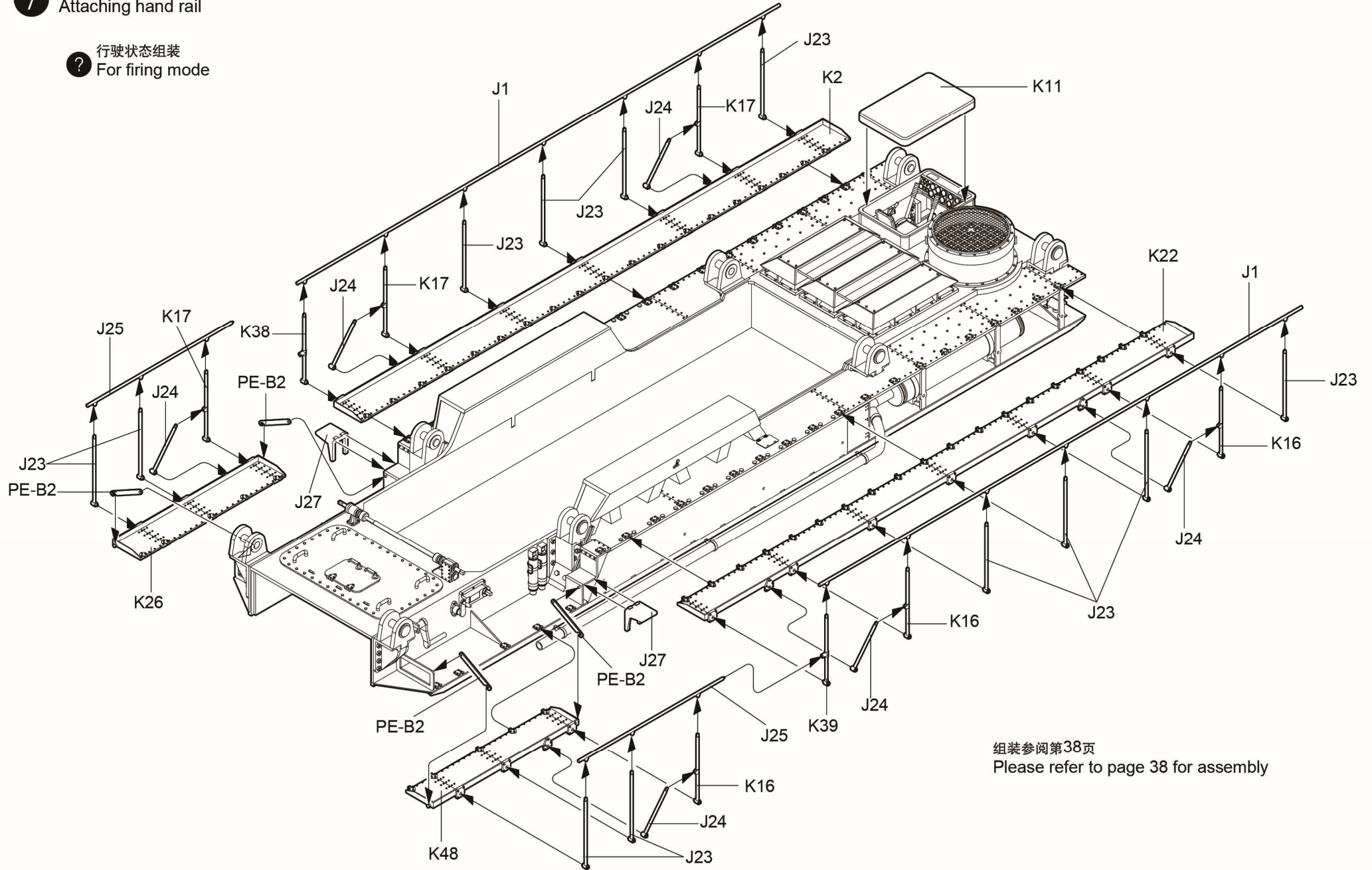

组装参阅第38页
Please refer to page 38 for assembly

8 车体上部组装
Upper hull assembly

? 行驶状态组装
For firing mode

全部对侧相同
Same as both sides

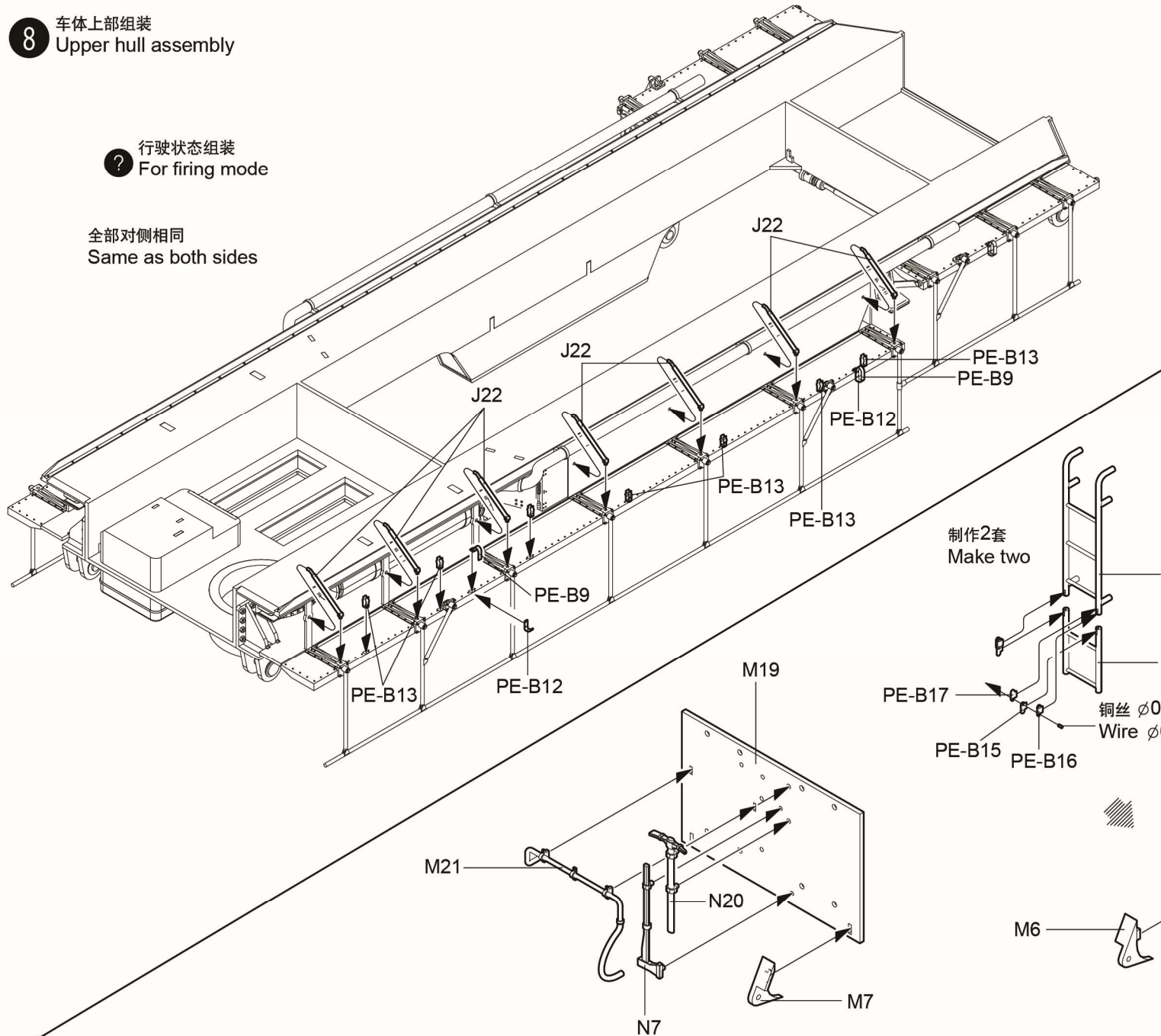

9 前挡板组装
Front panel assembly

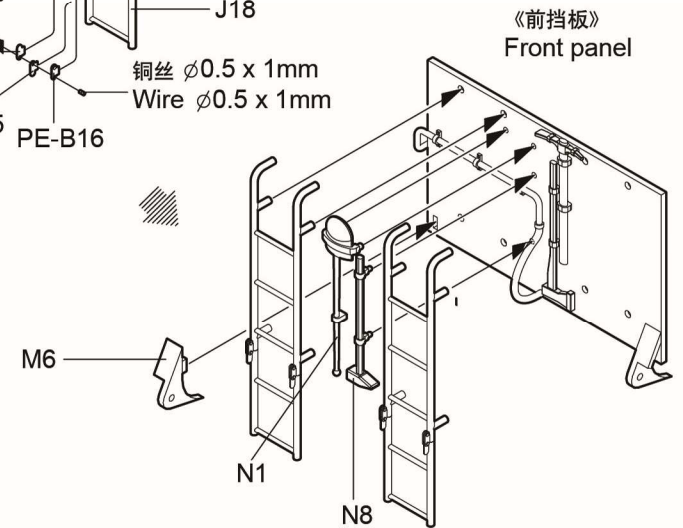
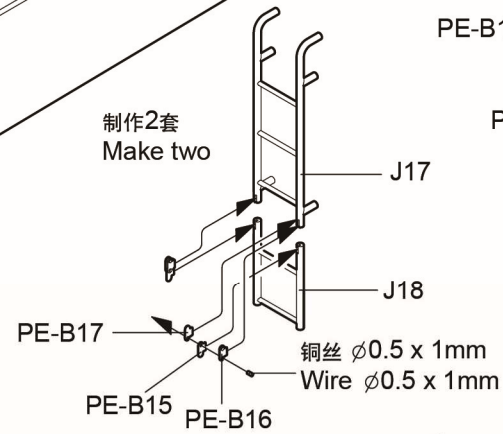
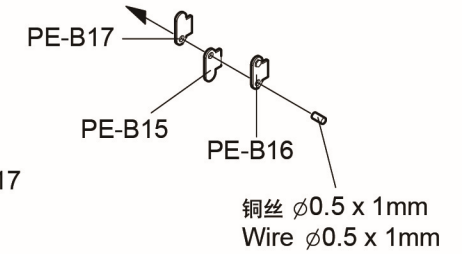
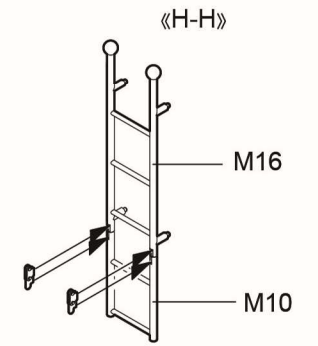

10 车体上部安装
Upper hull installation

钻穿图中涂黑的定位孔
Make holes

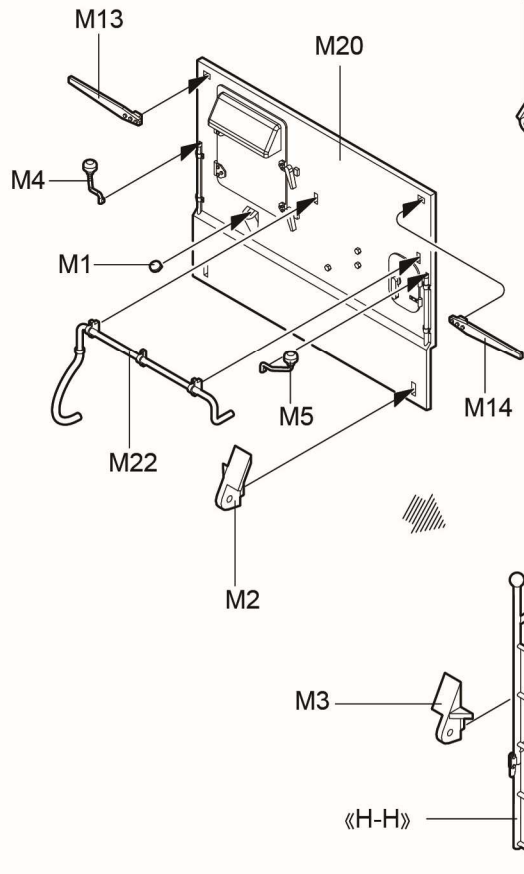
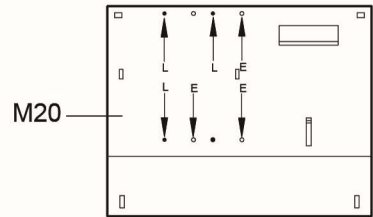

《前挡板》
Front panel

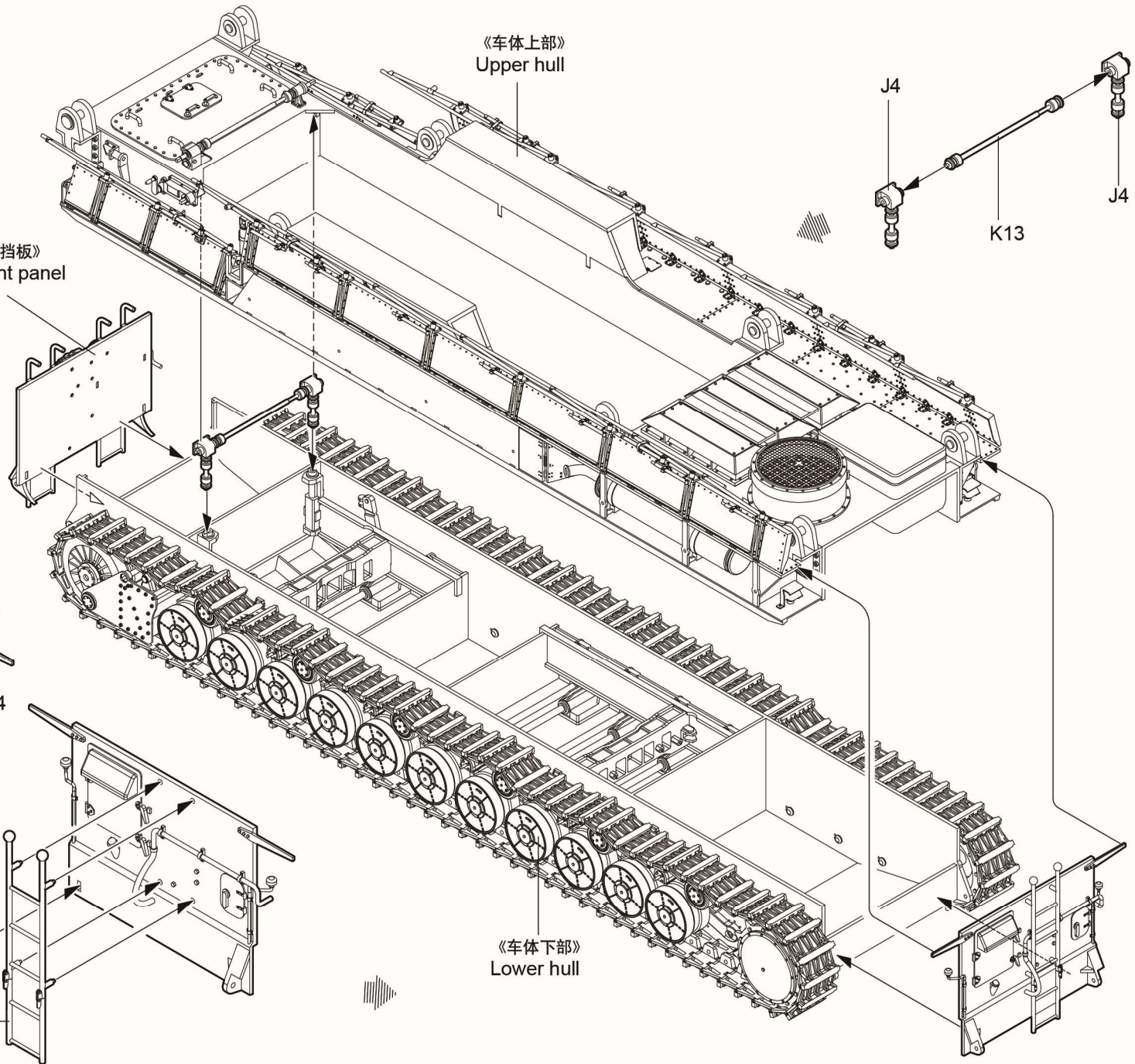

《车体上部》
Upper hull

J4

K13

J4

《车体下部》
Lower hull

《H-H》

11 炮管组装
Bore assembly

Table:Geraet Nr. IV to VI

Geraet Gun	Nr. IV "Thor"	Nr. V "Loki"	Nr. VI "Ziu"
600mm Geraet 040	★	★	★
540mm Geraet 041	★	★	

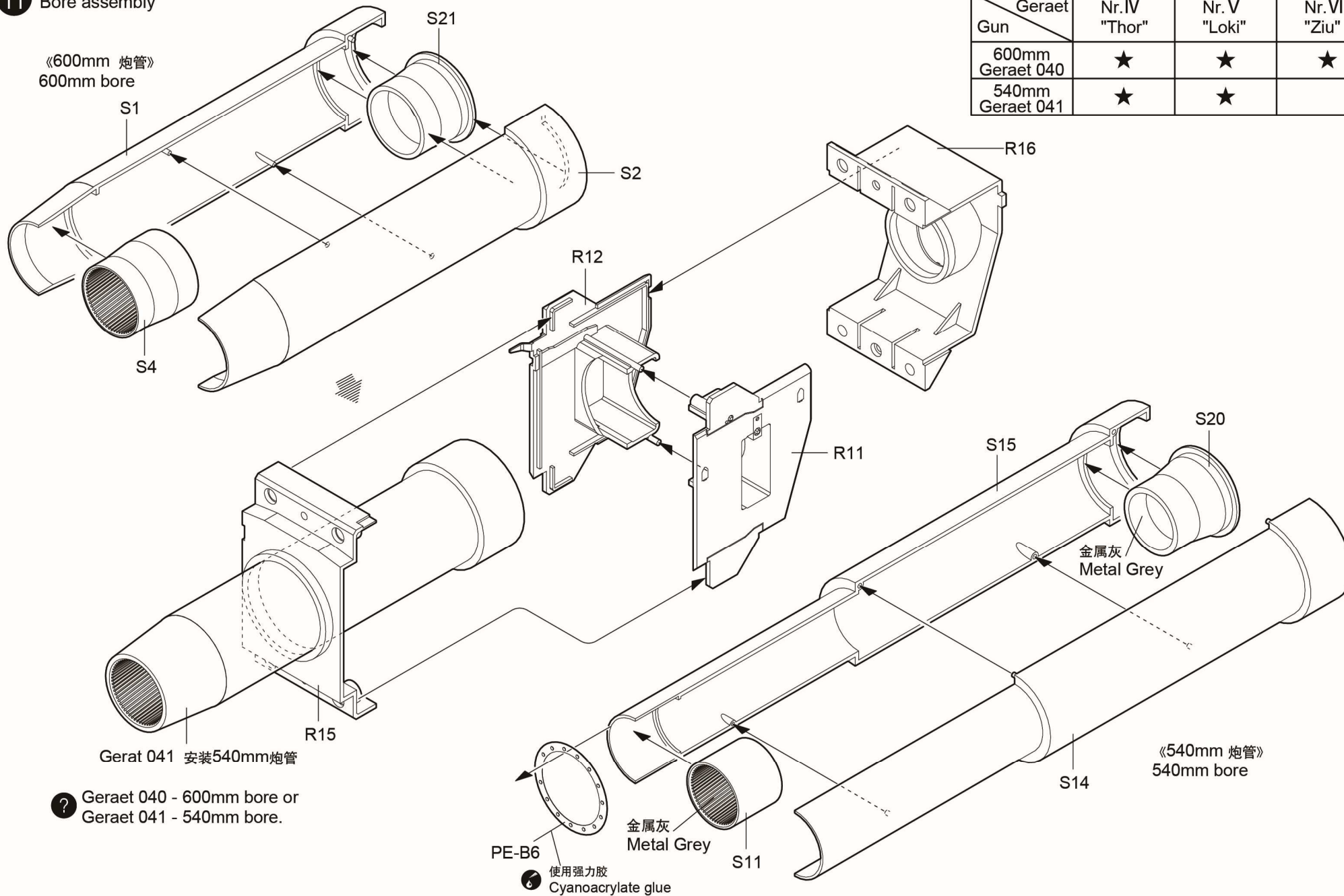

❓ Geraet 040 - 600mm bore or
Geraet 041 - 540mm bore.

12 火炮组装
Mortar assembly

非运输状态选择T8, 参阅第29页
Use T8 for firing mode, refer to page 29

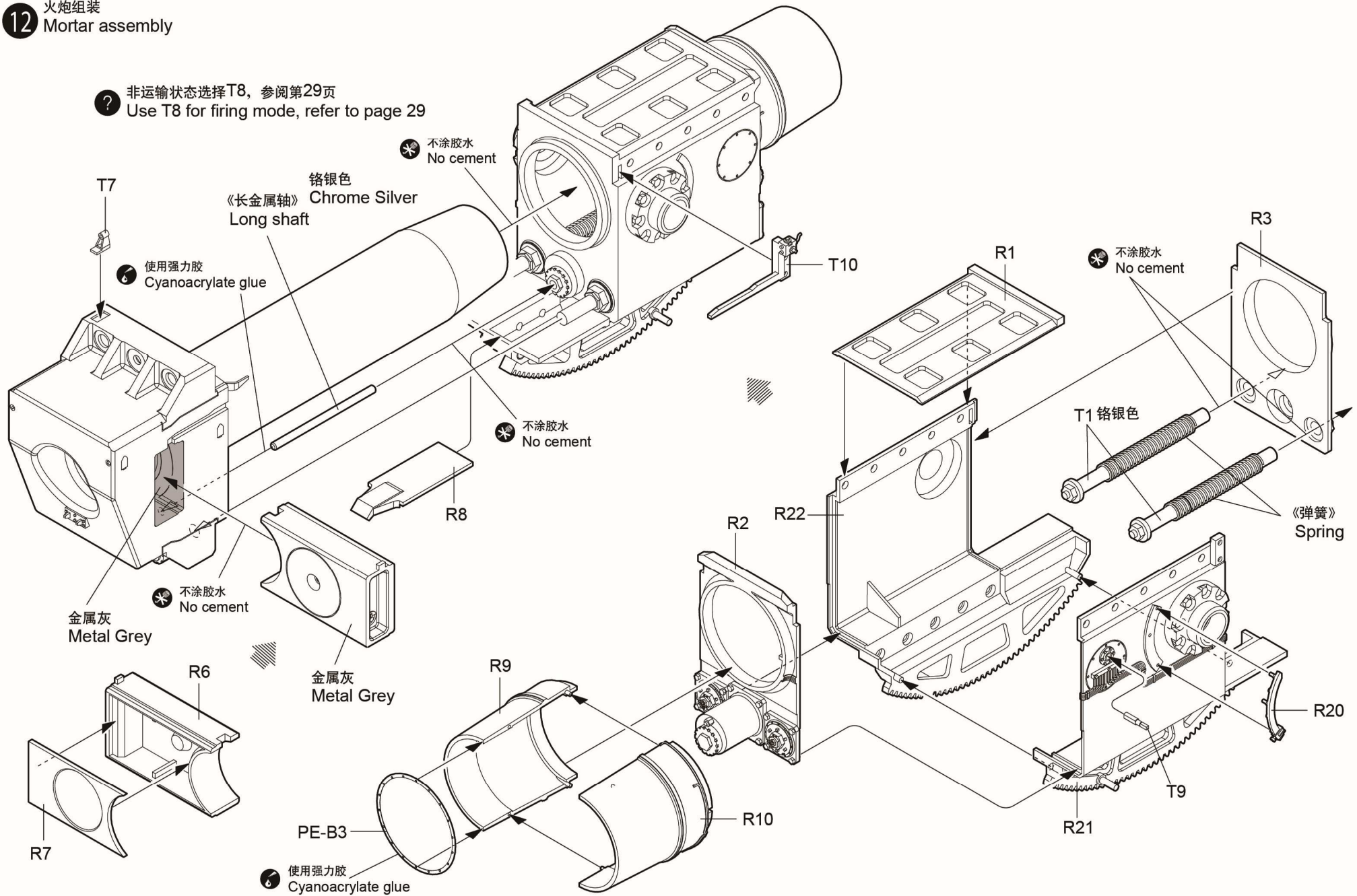

13 上部缓冲器组装
Upper recoil/buffer housing assembly

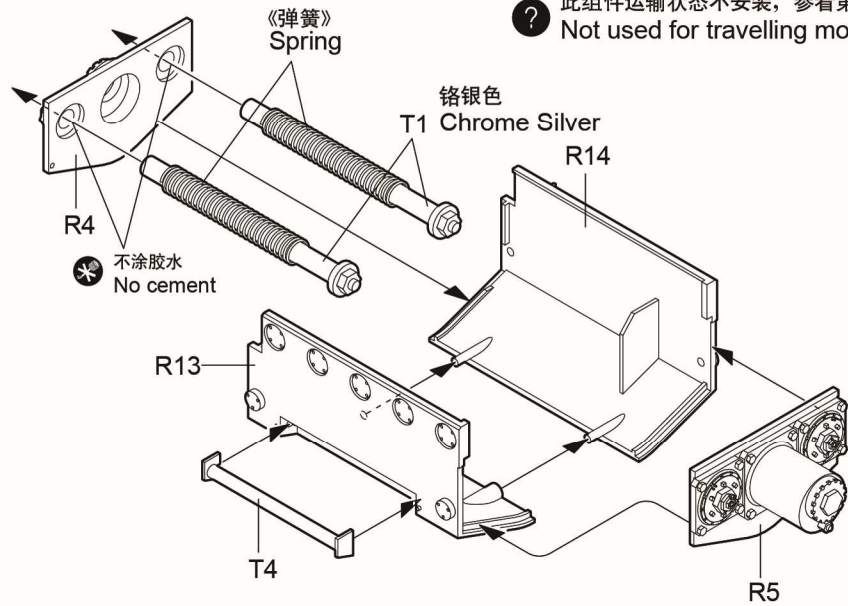

? 此组件运输状态不安装，参看第37页
Not used for travelling mode, refer to page 37

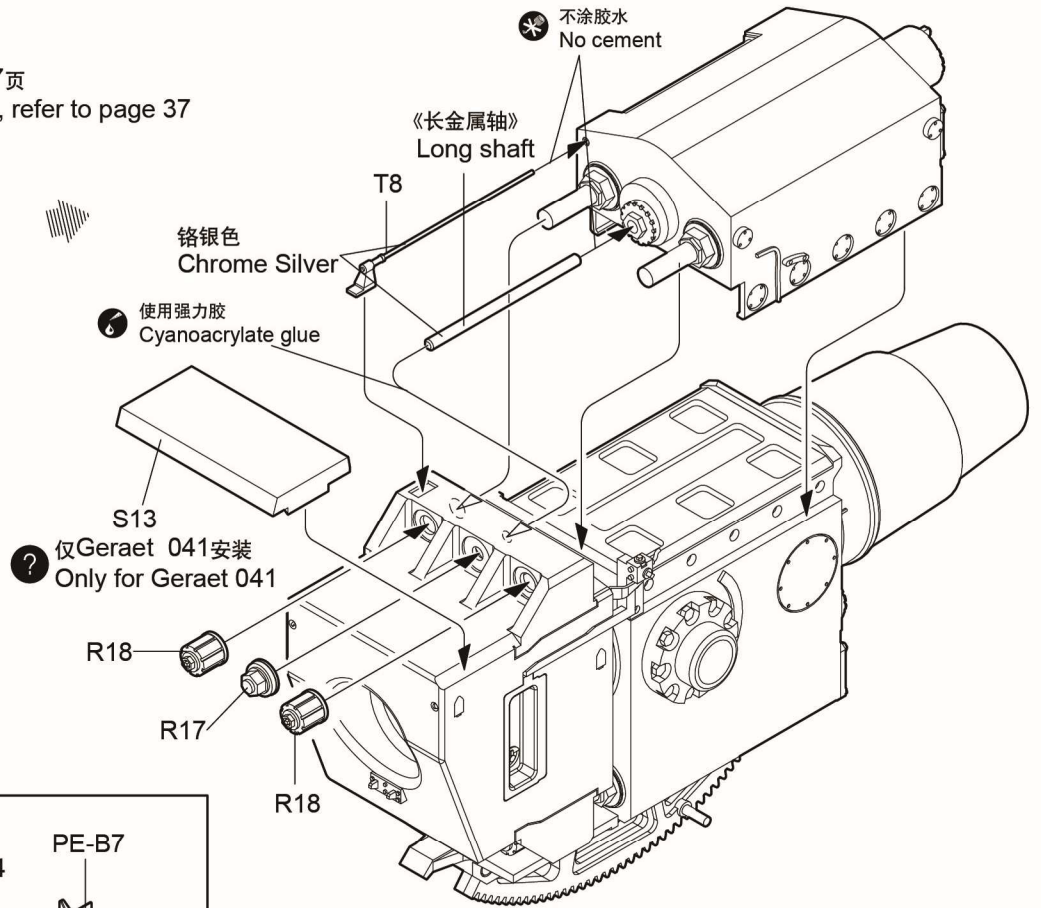

14 填弹槽组装
Loading tray assembly

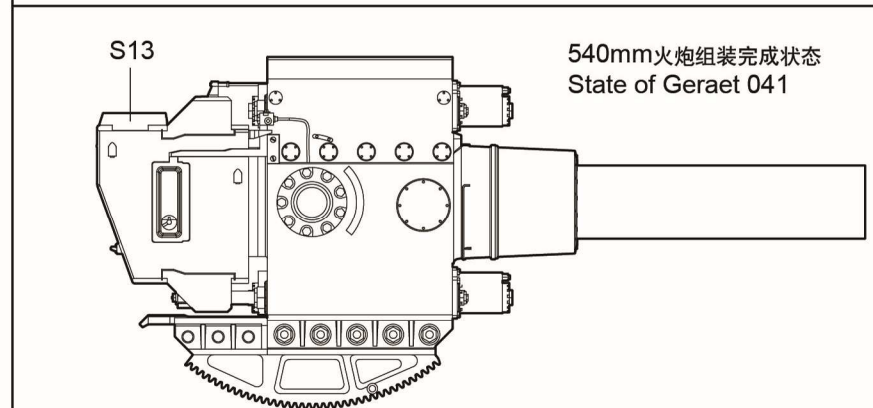
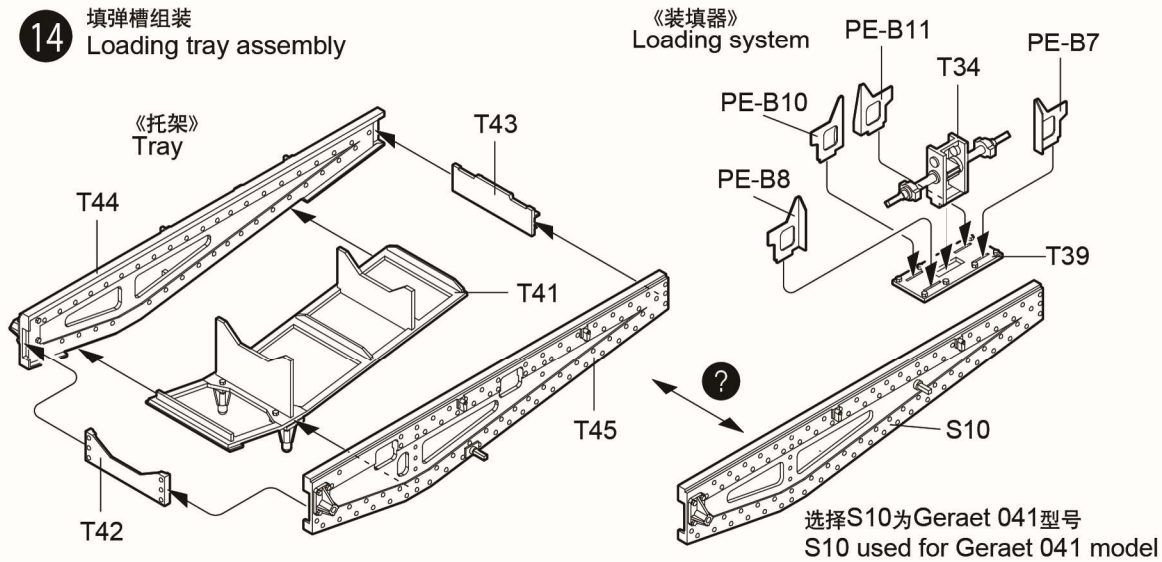

15 填弹槽组装
Loading tray assembly

《导轨》
Track

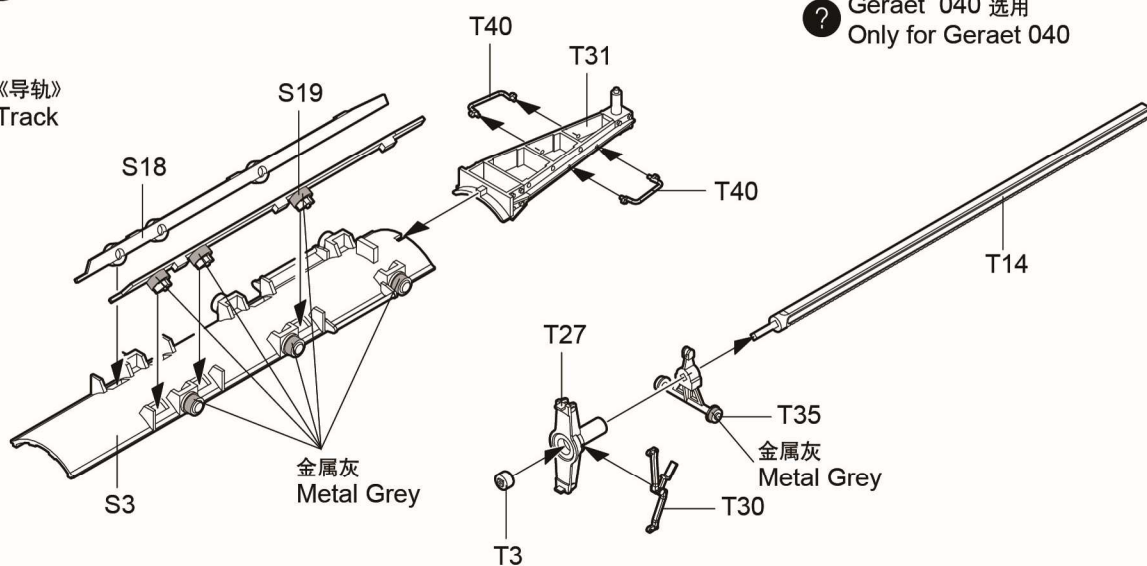

? Geraet 040 选用
Only for Geraet 040

《装填器》
Loading system

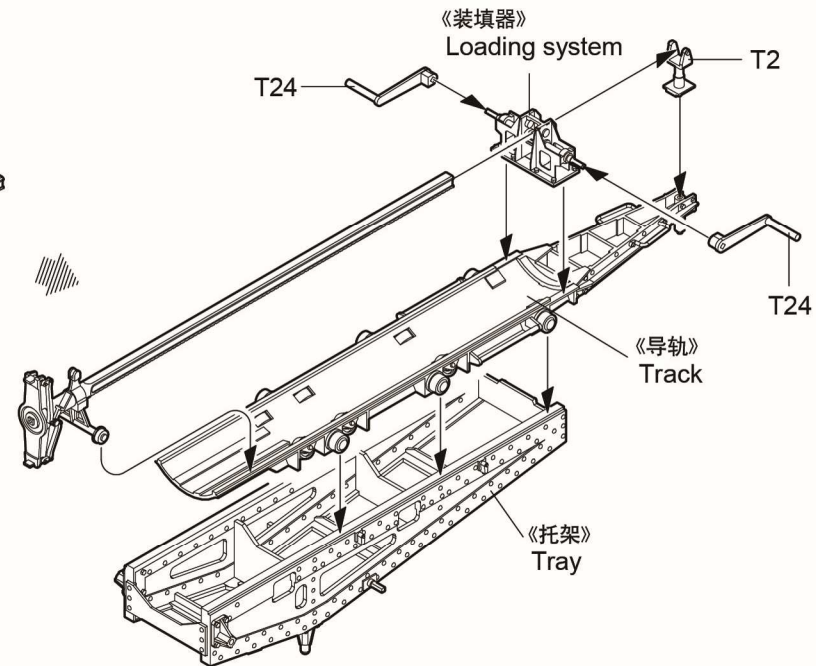

16 填弹槽组装
Loading tray assembly

《导轨》
Track

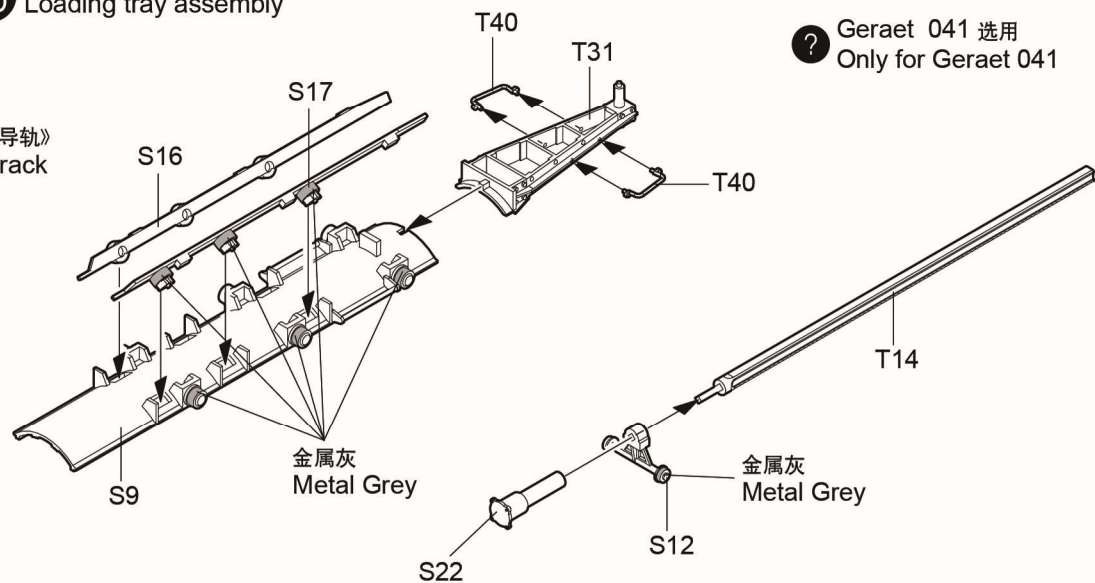

? Geraet 041 选用
Only for Geraet 041

《装填器》
Loading system

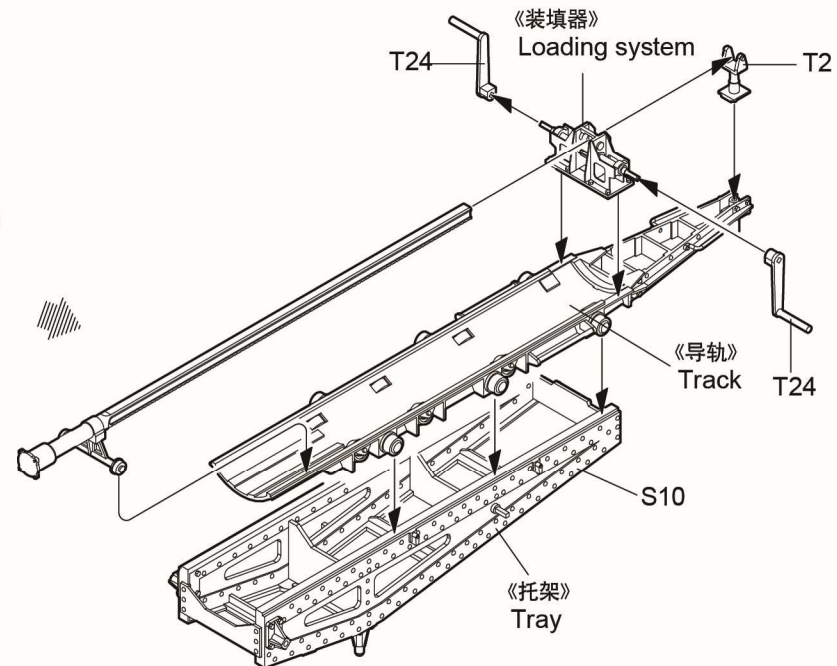

17 炮架组装
Carriage assembly

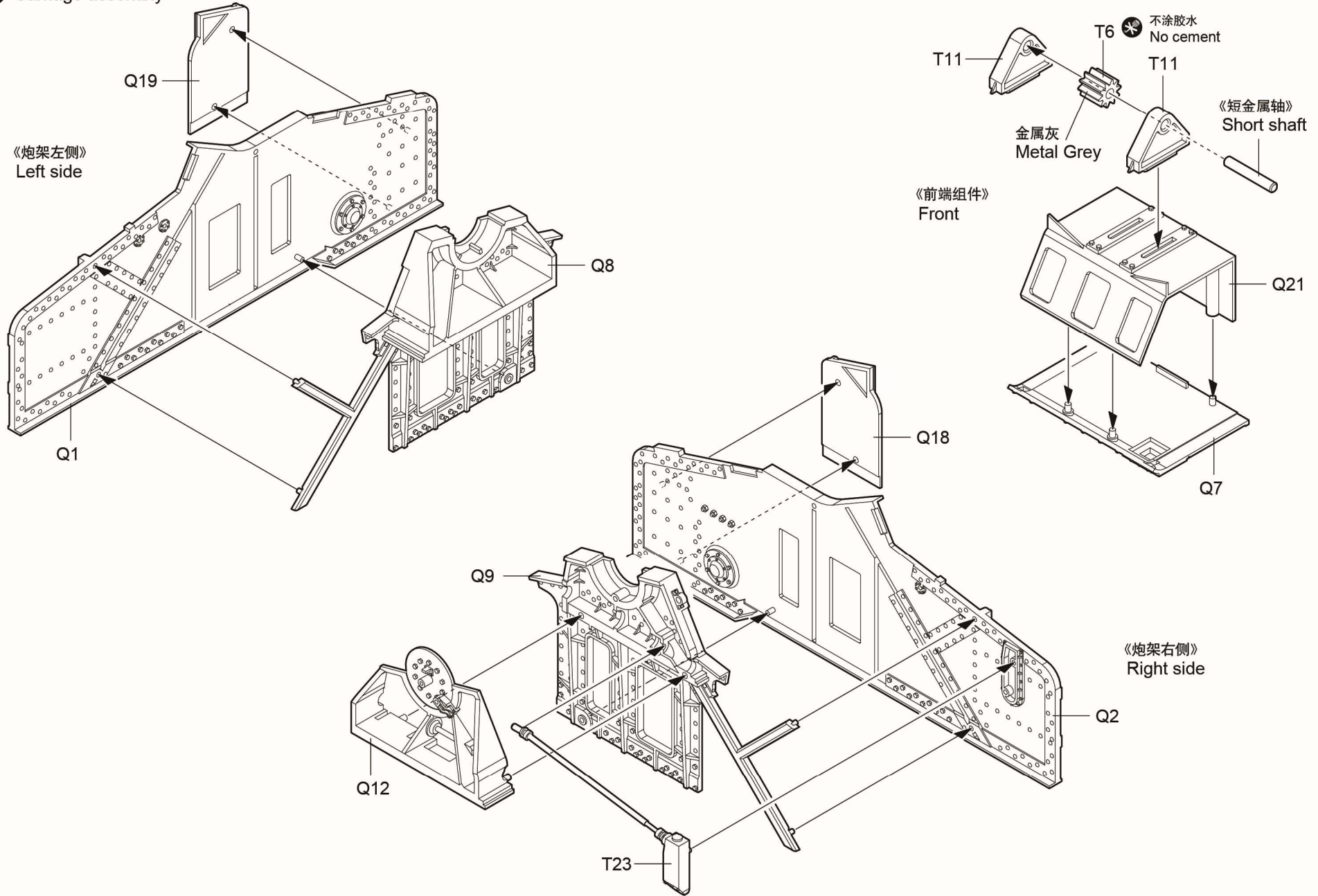

18 炮架组装
Carriage assembly

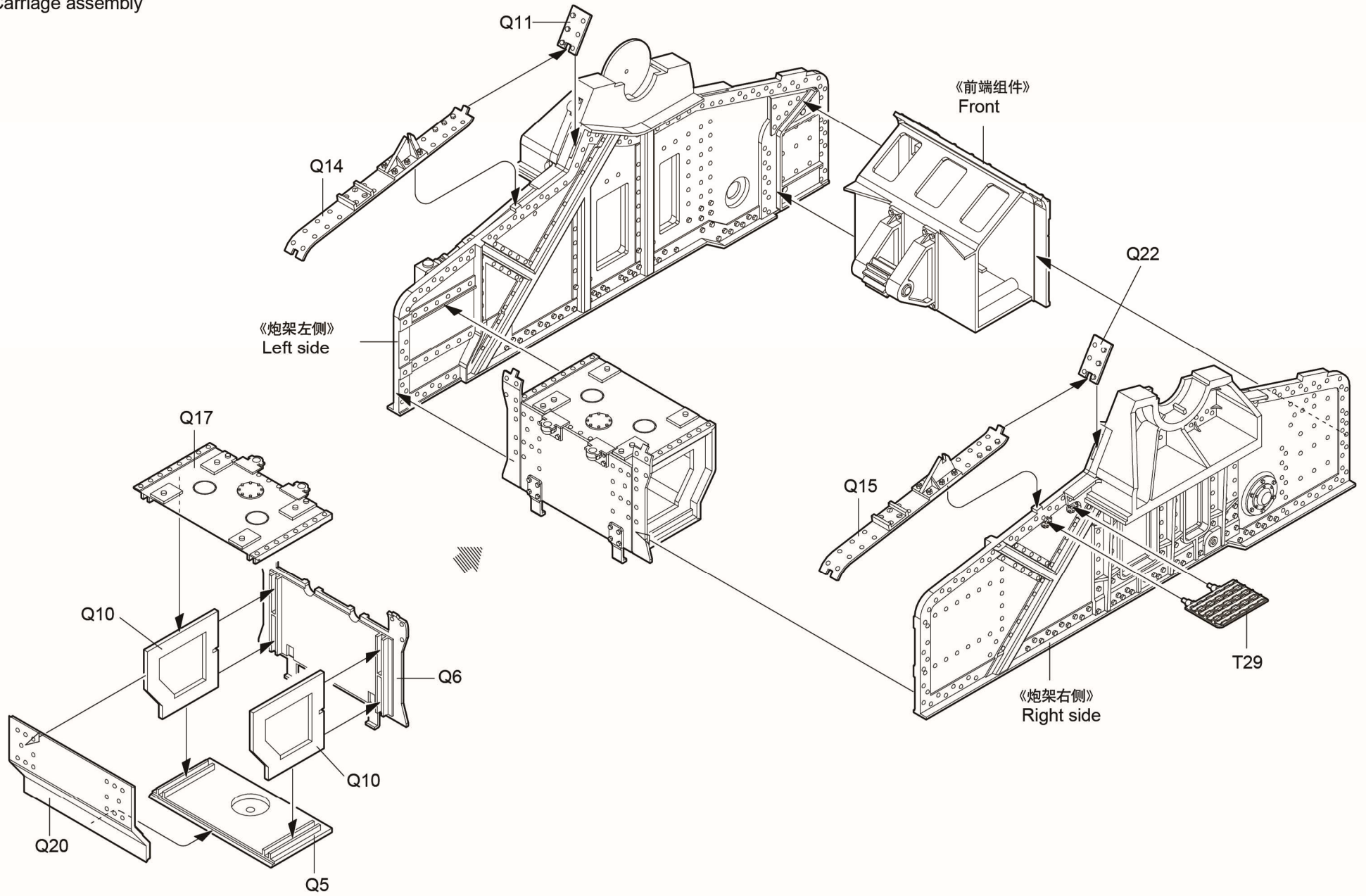

19 炮架组装
Carriage assembly

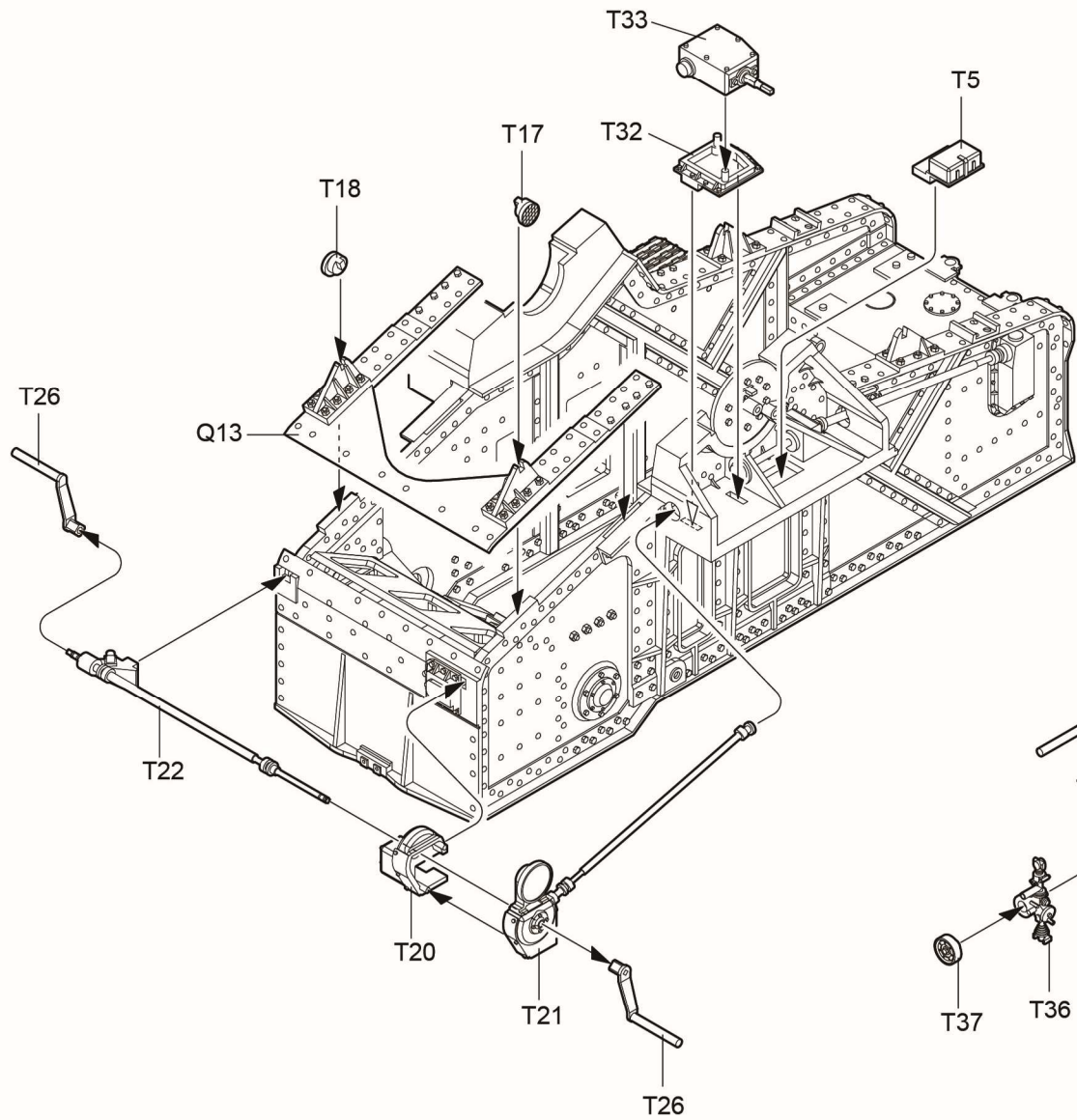

20 炮弹组装
Shell installation

Geraet 040 选用
Only for Geraet 040 《重磅炮弹》
Heavy shell

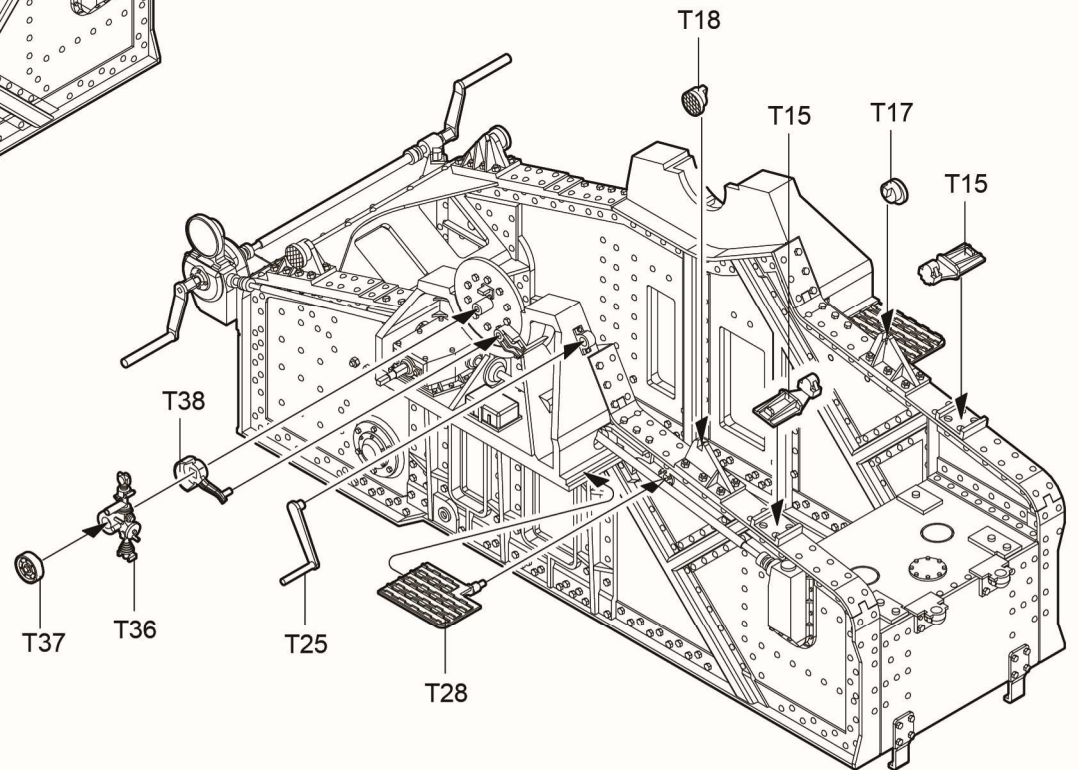
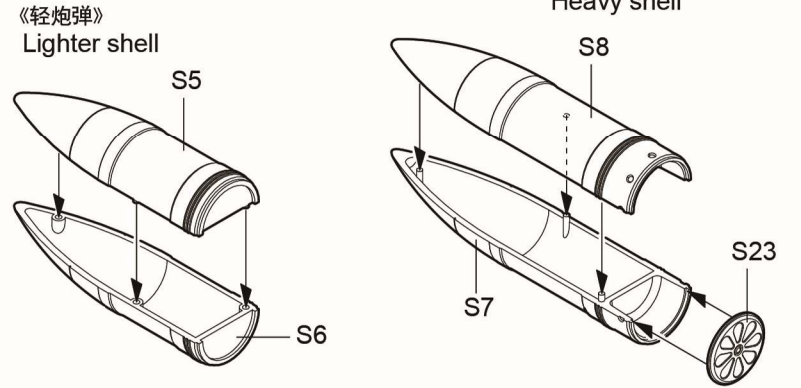

21 火炮组装
Mortar installation

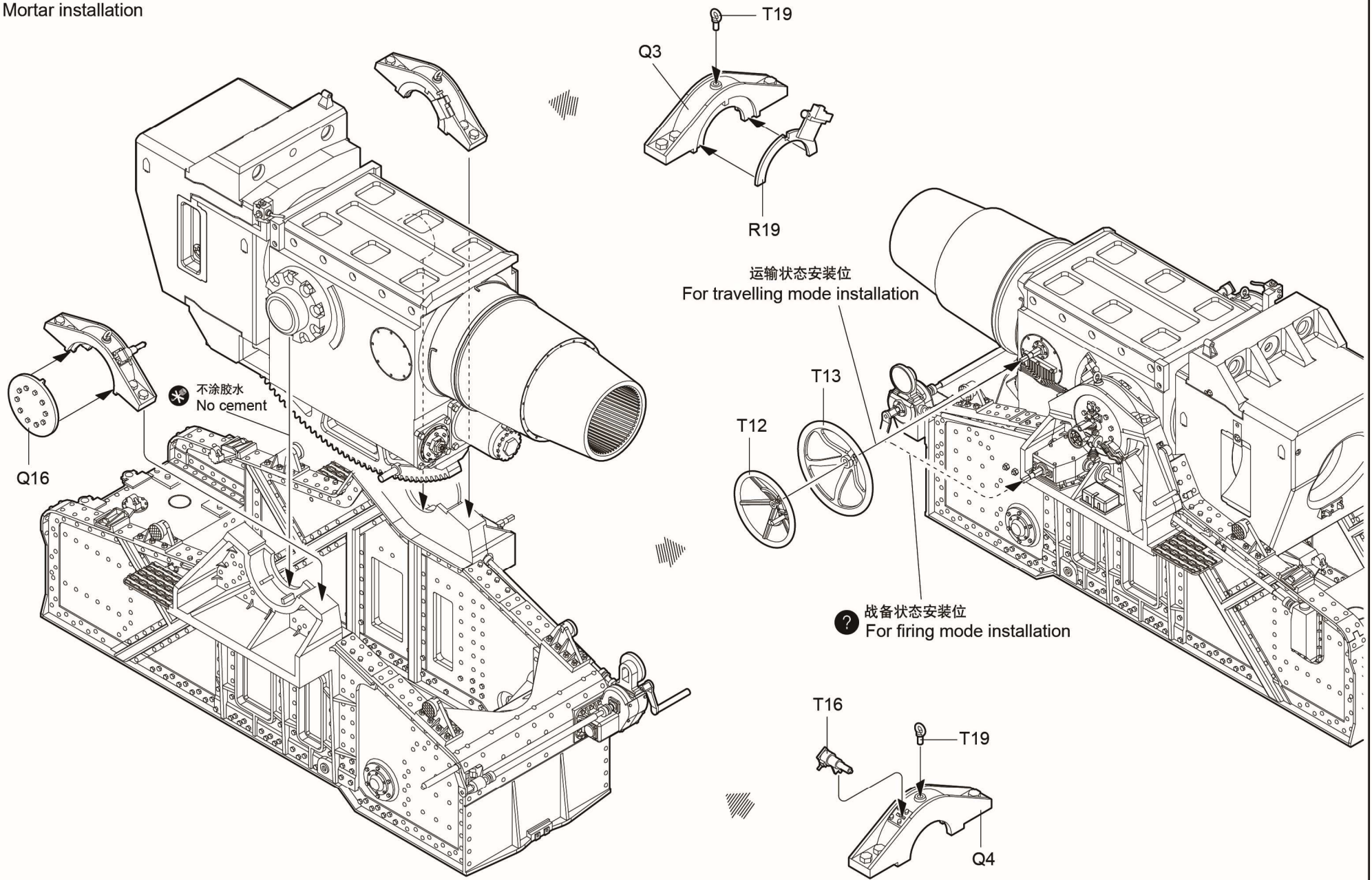

22 火炮安装
Attaching Mortar

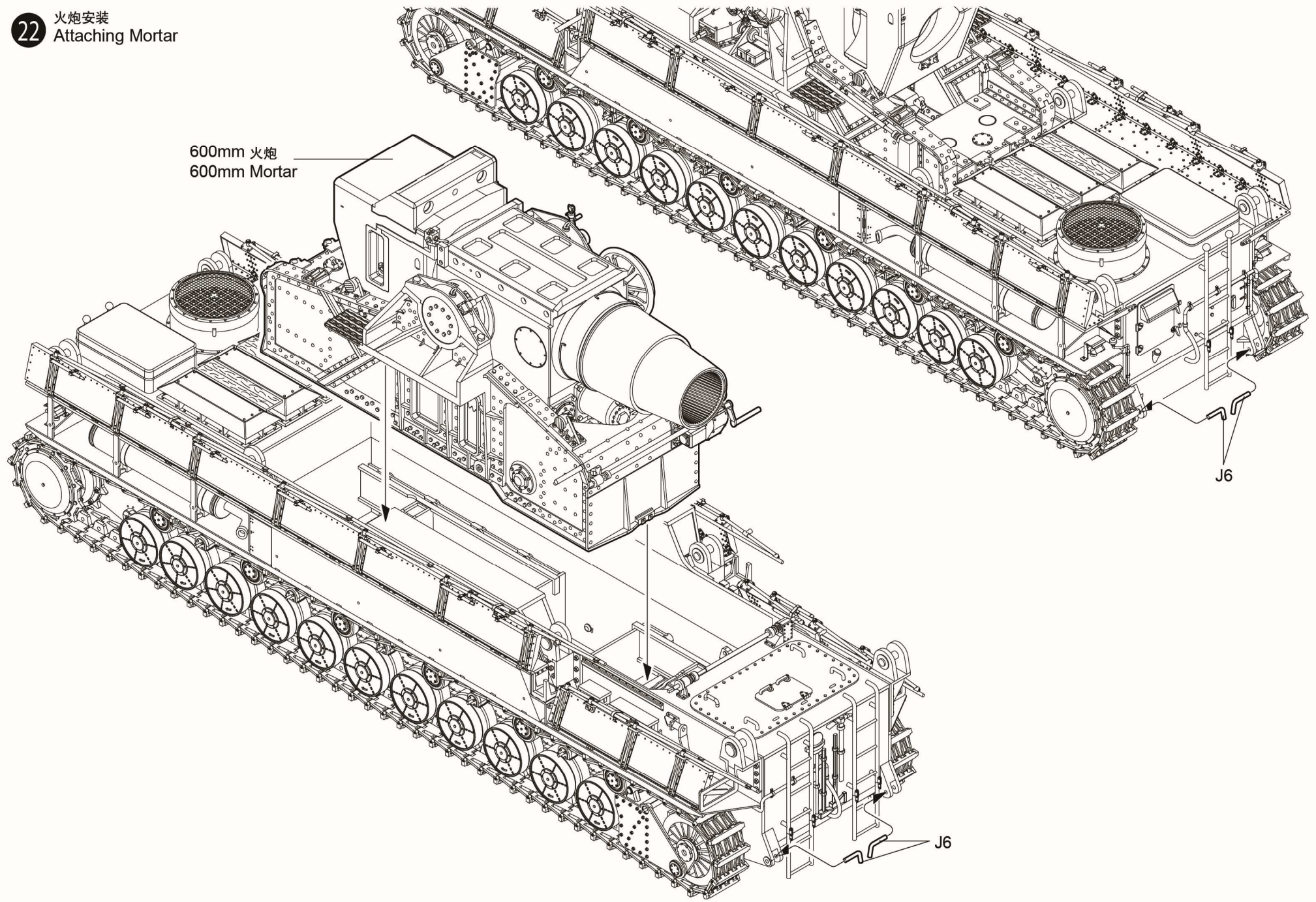

23 运输车连接
Truck construction

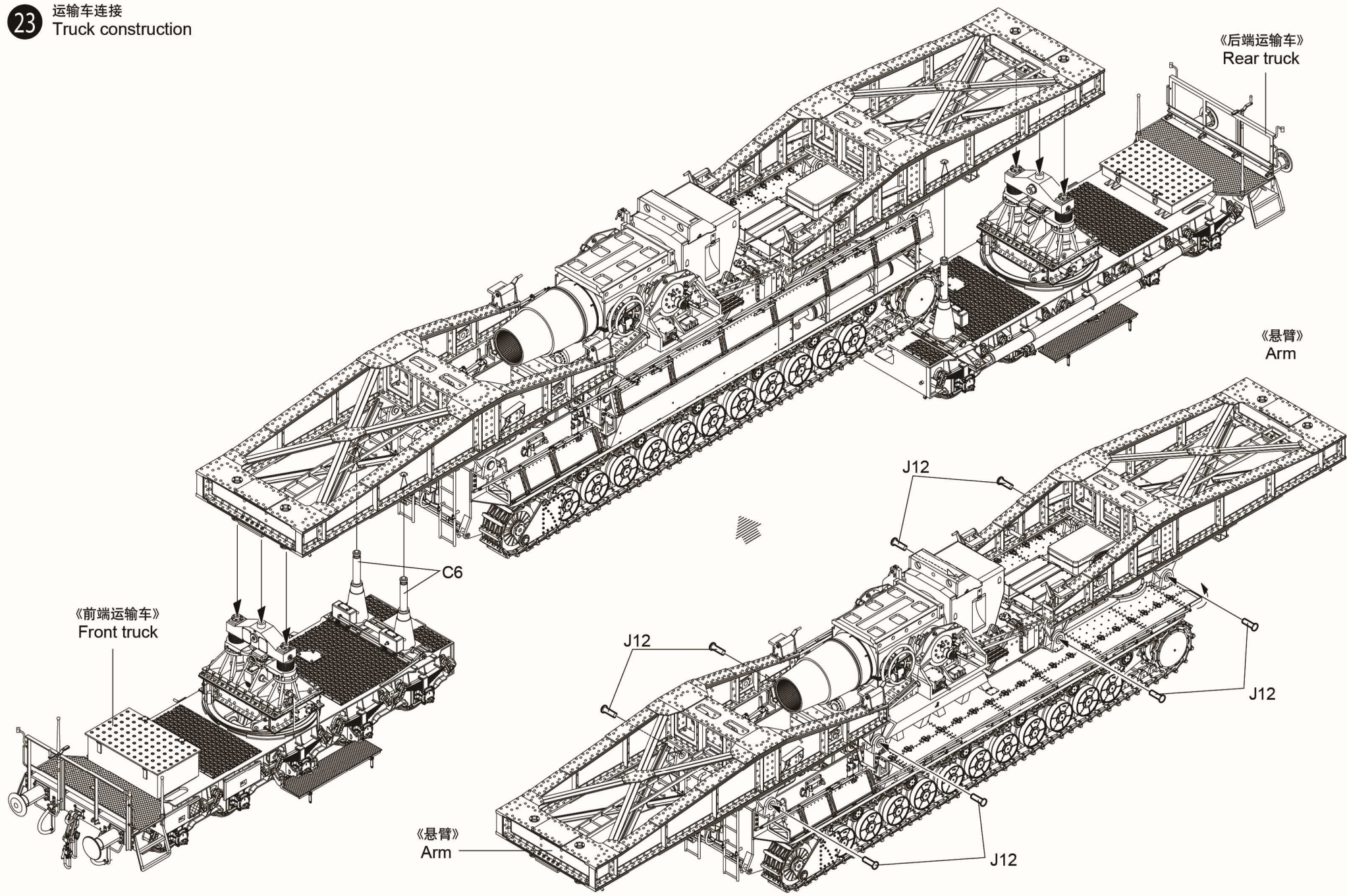

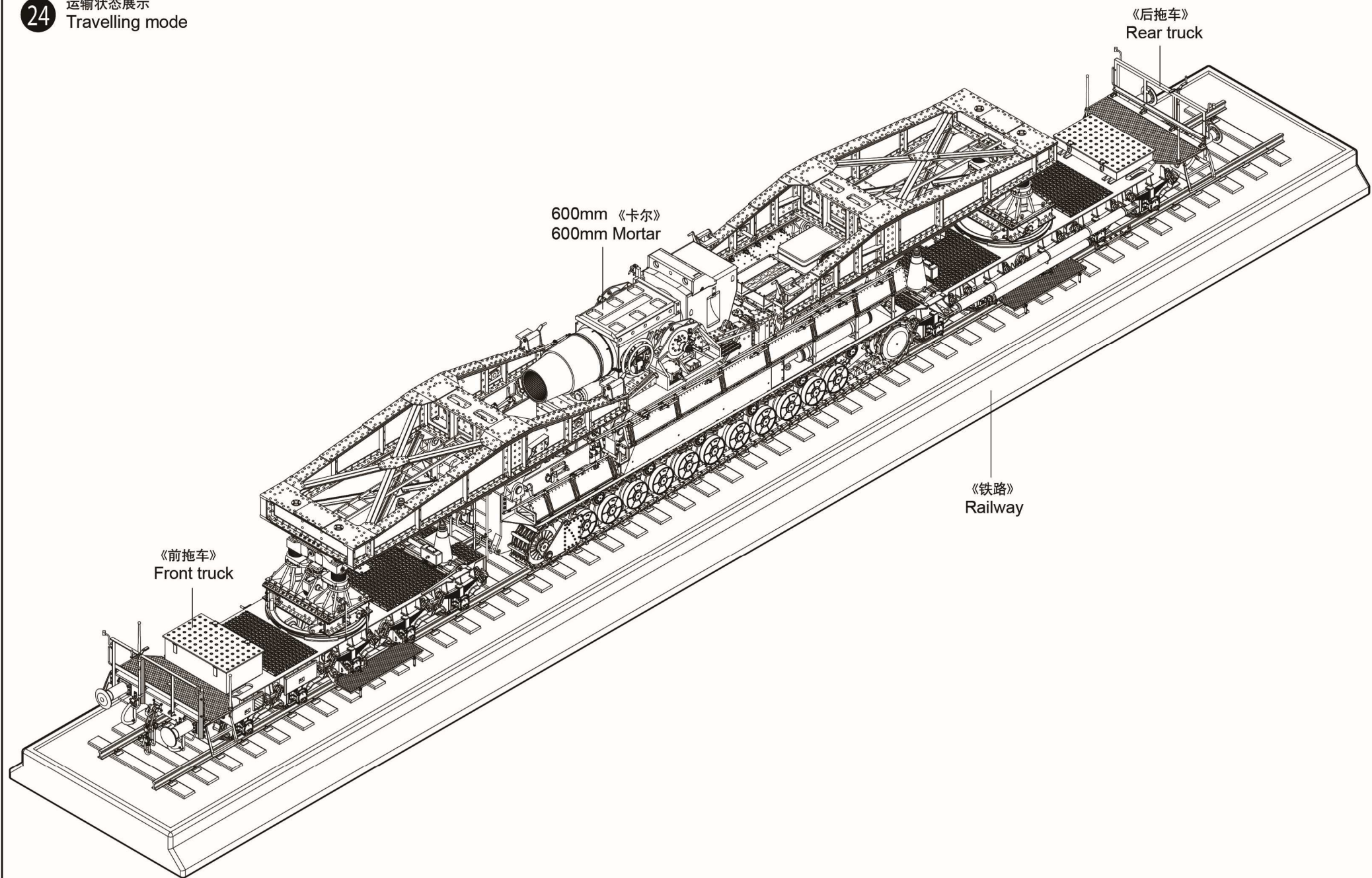

? 可选择场景
Optional mode

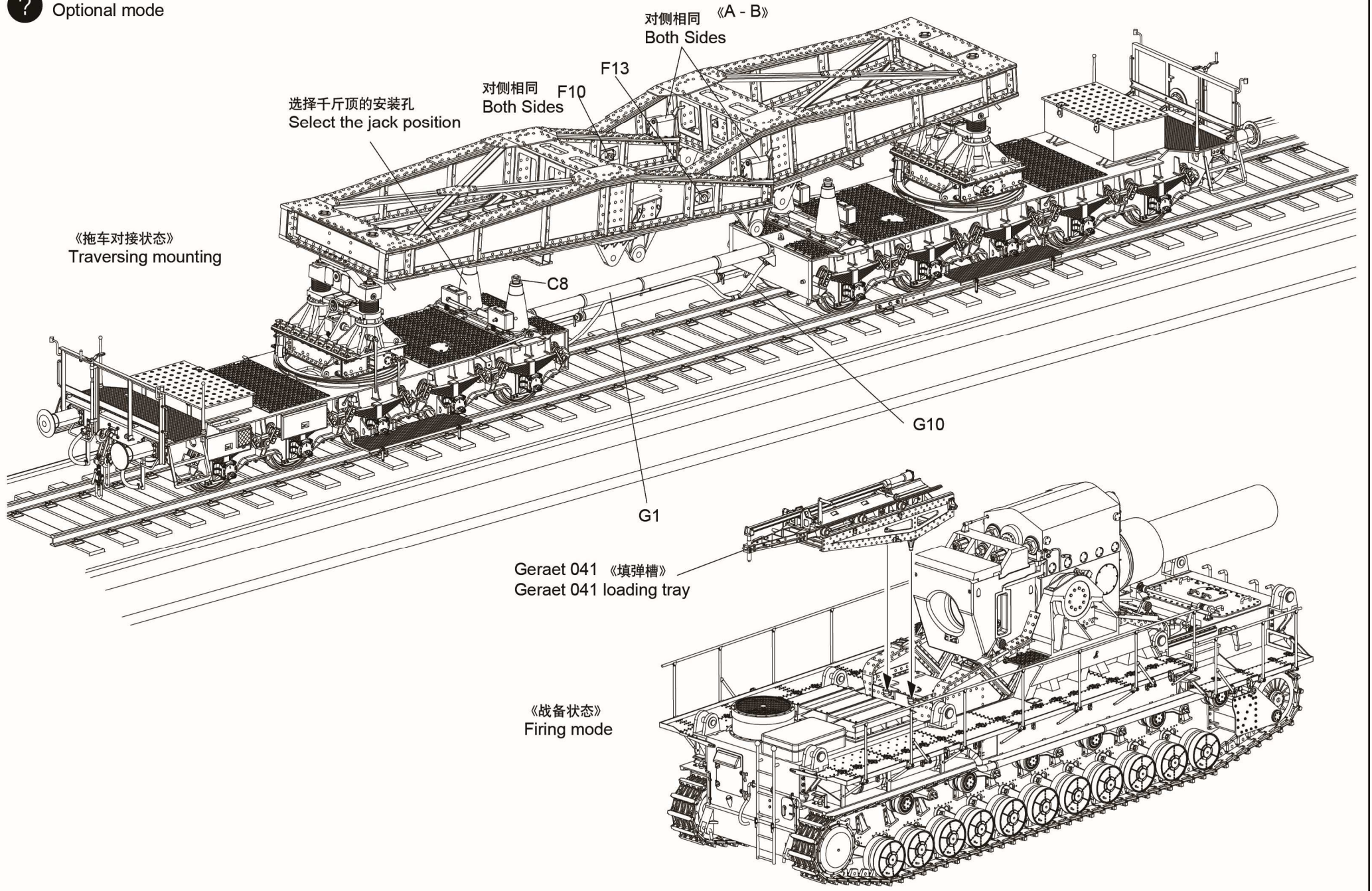

涂装同标贴指示
Painting & Marking guide

Nr. IV — Thor
Nr. V — Loki
Nr. VI — Ziu

Testor	Gunze	颜色	色号
2100	41	红棕色	Signalbraun RAL8002
2097	54	绿色	Panzer olivgran 1943
2095	19	暗黄色	Panzer Dunkelgelb 1943
2094	60	深灰色	Drak grey RAL7021

-  暗黄色
Panzer Dunkelgelb 1943
-  红棕色
Signalbraun RAL8002
-  绿色
Panzer olivgran 1943

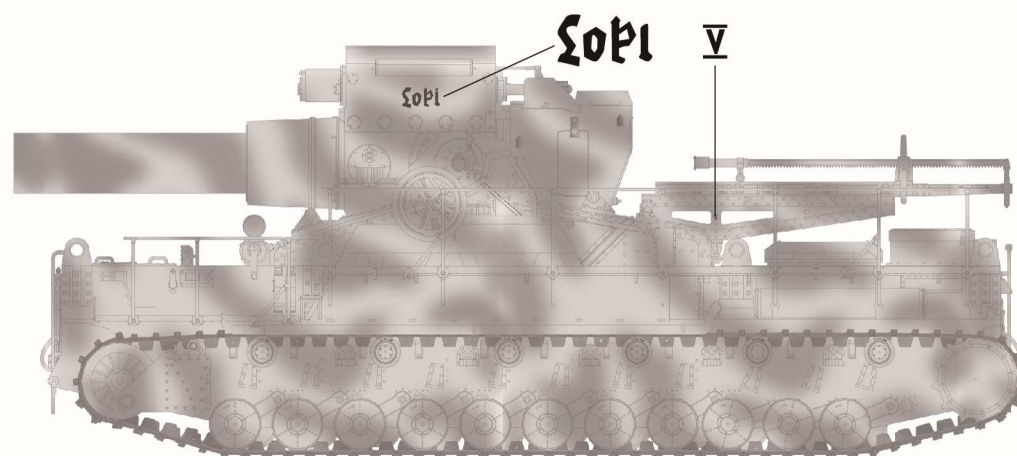
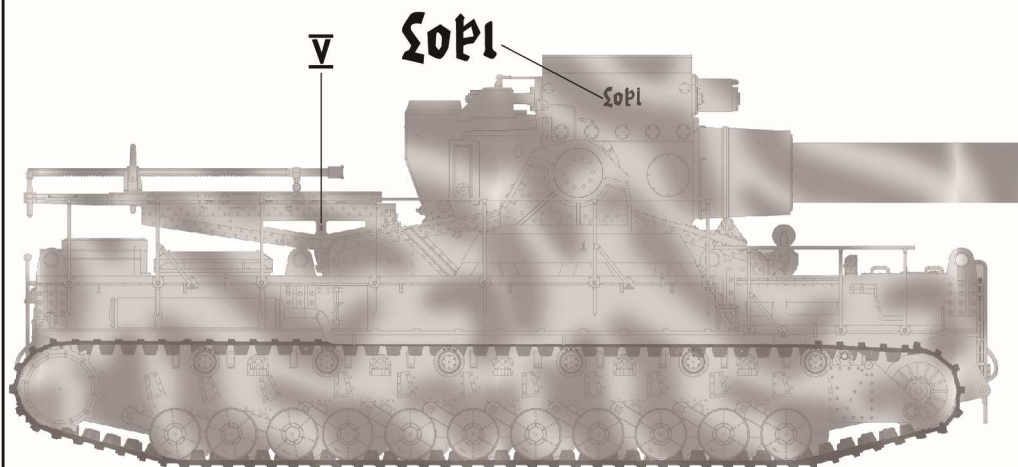
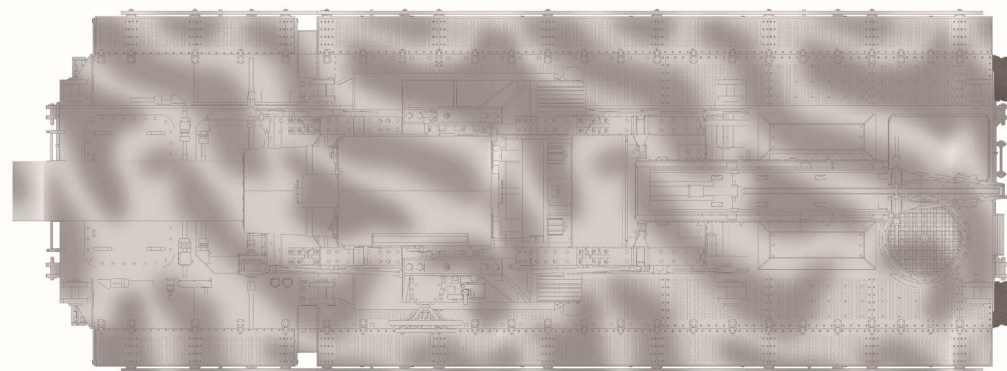
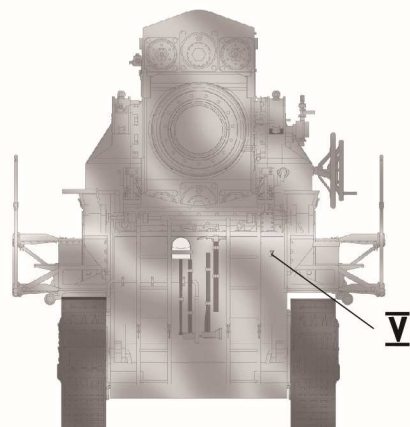
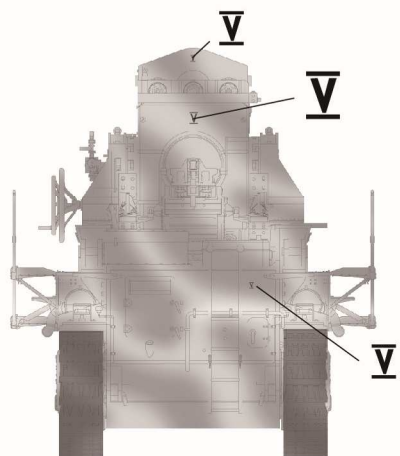

涂装同标贴指示

Painting & Marking guide

深灰色
Overall dark grey RAL 7021

